



DRIVE SOLUTIONS

Solutions for Variable
Frequency Drive Applications



HPS Drive Solutions Solutions for Variable Frequency Drive Applications

Our Experience

The variable frequency drive (VFD) market covers a broad range of applications and environments, demanding a high level of performance and reliability. Adding a VFD to any system results in increased efficiency, better process control and reduction in the wear and tear of the equipment. However, VFDs also cause power quality issues such as harmonics on the line side and reflected wave voltages on the load side.

VFD's can also be susceptible to power quality issues from other systems that can damage a VFD or cause nuisance tripping. HPS can provide comprehensive solutions to these costly problems.

Whether it's a standard transformer, reactor, filter or a custom built magnetic, HPS has the experience to provide a solution for your drive application.

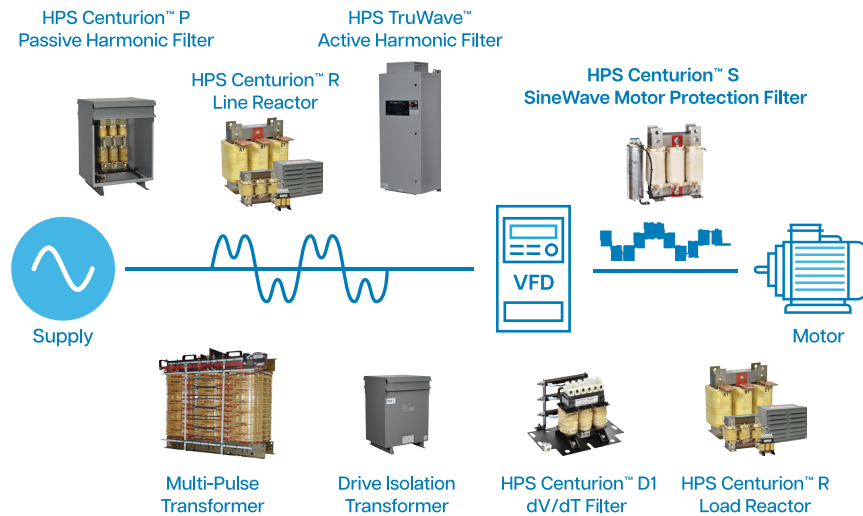

Line Side Drive Solutions

HPS TruWave™ Active Harmonic Filter

HPS TruWave™ Active Harmonic Filter (AHF) is a comprehensive and flexible solution for harmonic mitigation. It provides advanced control and proven reliability that your facility needs to solve harmonic problems generated by non-linear loads such as variable frequency drives.

The AHF monitors load current and quickly responds to power system distortion as it develops. The AHF injects a corrective current to effectively cancel out harmonics produced by three phase non-linear loads. The result is a reduction in harmonic distortion to below 5%, complying with the IEEE-519 recommendations.

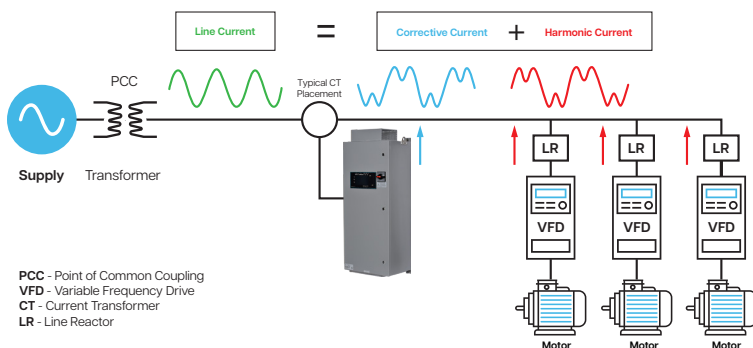

HPS TruWave™

Powered by **MESTA Electronics**

HPS Centurion™ P Passive Harmonic Filter

HPS Centurion™ P passive harmonic filter is specifically engineered to mitigate harmonic currents created by non-linear loads. It is currently available from 5 to 500 horsepower and it improves power quality by simultaneously reducing harmonics and improving true power factor. The advanced HPS design delivers superior performance compared to a traditional harmonic filter by reducing harmonic current distortion by 80% (typically to 5% or less at full load), corrects true power factor to over 95%, and meets IEEE 519 harmonic requirements when operated within designed parameters.

HPS Centurion P consists of reactors and capacitors in an LCL arrangement designed to reduce a broad range of harmonics associated with variable frequency drives and other three phase rectifiers. Capacitor contactor is available as an option.

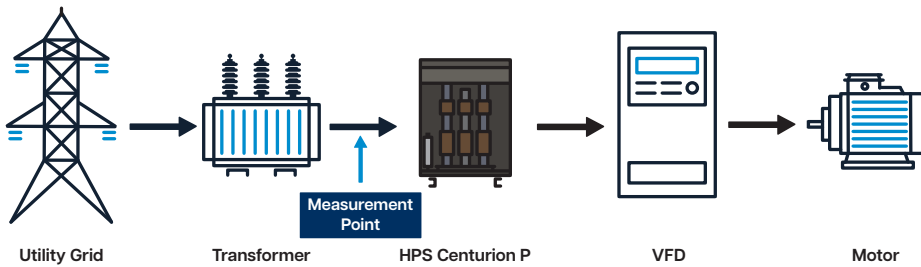

HPS Centurion™ R Line Reactor

The HPS Centurion™ R line reactor provides a U.L. listed solution to many common drive issues. As an input line reactor, the HPS Centurion R offers the following benefits:

- Minimizes harmonic current
- Attenuates voltage and current harmonics to reduce voltage notching
- Improves True Power Factor by reducing overall current distortion
- Mitigates drive nuisance tripping by attenuating voltage transients from sources such as PFCC, utility switching and lightning

When coordinated with a HPS TruWave Active Harmonic Filter, the system can reduce harmonics from variable frequency drives to under 5% THD.

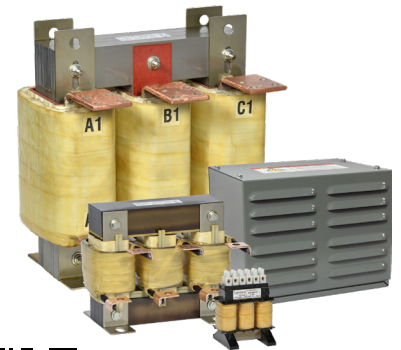

(a) single motor

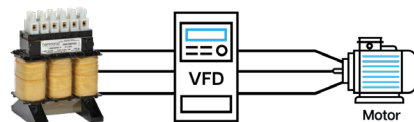

(b) multiple motors

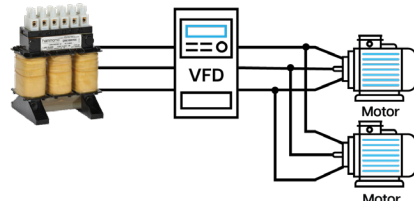

Line Side Drive Solutions Continued

HPS Drive Isolation Transformer

HPS Drive Isolation Transformers (DITs) are designed to meet the rugged demands of both AC and DC variable speed drives and also to provide any required voltage change. The harmonic distortion generated by non-linear loads can have damaging effects on the transformer and electrical equipment connected to the circuit.

Drive Isolation Transformers are used for VFD applications to create isolation between the source and loads as well as impedance to the line. DITs offer the following benefits:

- Changes voltage where required
- True electrical isolation and dedicated grounding point
- Limits maximum short circuit current

HPS offers both standard efficiency DITs, primarily for the US market, and high efficiency versions required for Canada to meet NRCan 2019 efficiency regulations.



Standard Efficiency



High Efficiency

HPS Multi-Pulse Transformer

Multi-Pulse transformers are designed specifically for harmonics, voltage distortion and other unique characteristics associated with individual manufacturer's drive systems. They provide the required supply voltage with the desired phase angle between secondary voltages for VFD systems/converters.

HPS has significant experience with 18, 24, 36, 48 pulse drive/inverter duty transformers and auto-transformers in both low and medium voltage applications.

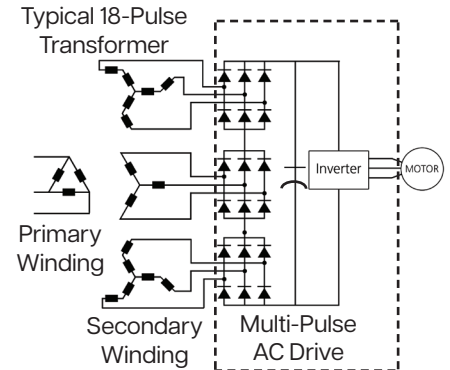

Typical Drive Current Waveforms



Custom Reactor Solutions

Through our extensive application and design knowledge we are able to provide both iron and air core reactors as well as chokes for a variety of low and medium voltage solutions:

- DC link chokes
- Current limiting reactors

In addition, HPS can supply reactors to be integrated as a component in a variety of filters and harmonic traps.



Load Side Drive Solutions

HPS Centurion™ R Load Reactor

The HPS Centurion™ R load reactor provides a U.L. listed solution to many common drive issues, with the following benefits:

- Reduces the motor's operating temperature & audible noise
- Mitigates motor bearing failures and insulation damage as a result of the reflected wave phenomenon
- Enhances the overall performance and life expectancy of the motor

(a) single motor



(b) multiple motors

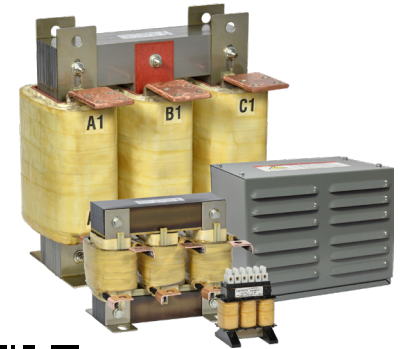
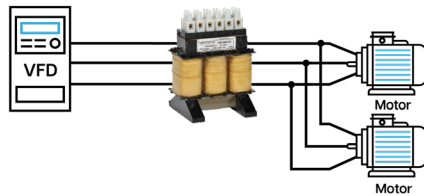

dV/dT Filter

The HPS dV/dT filters are specifically designed for use between variable frequency drives (VFD's) and motors when long lead lengths are used.

The HPS Centurion D1 dV/dT filter combines an inductor and parallel resistor network to mitigate both high frequency components and voltage spikes between the VFD and motor.

This can mitigate the effects in reflected wave voltages in lead lengths greater than what a reactor alone can accomplish. dV/dT filters provides protection to the motor by slowing down the rate of voltage increase and minimizes the damaging peak voltages that occur within the motor's windings and terminals.

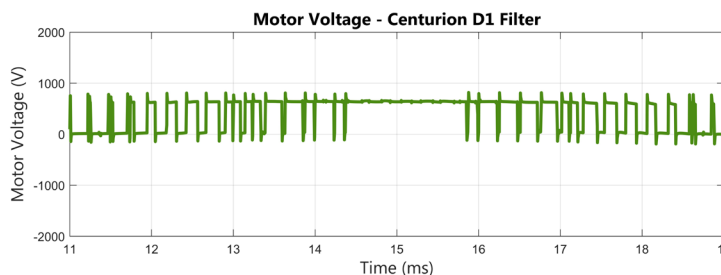
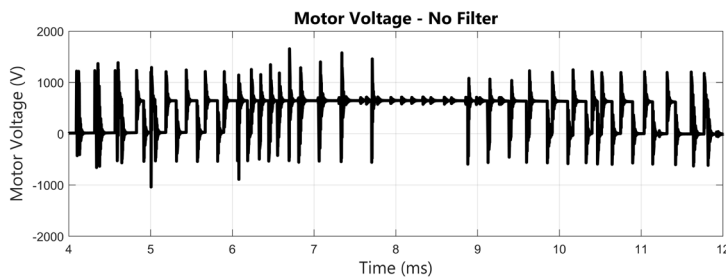
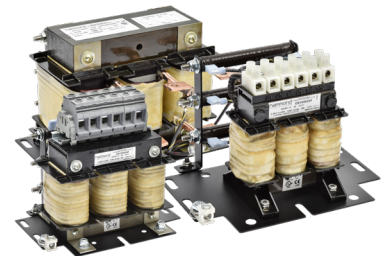

HPS Centurion™ S SineWave Filter

The Centurion™ S SineWave Motor Protection Filter is an easy and rugged solution to convert a Variable Frequency Drive's (VFD) pulse width modulated (PWM) output into a nearly perfect sinusoidal waveform. Motors with long lead lengths between a VFD experience high frequency currents and voltage spikes which will damage or destroy the motor. HPS Centurion S is a modern solution to protect and extend the life of the motor, increase efficiency, and allow it to run cooler.

Electrical Product Characteristics

- Voltage Rating: 380V – 480V and/or 600V (consult HPS for other voltage requirements)
- Current Rating: 9A to 600A

Technical Product Characteristics

- Harmonic Voltage Distortion: 5%
- Inverter Switching Frequency (Carrier Frequency): 2kHz to 8kHz
- Inverter Operating Frequency (Output Frequency): maximum 90Hz
- Insertion Loss (Voltage Drop): 5%
- Maximum Cable Length (motor lead): up to 15,000 feet (4572 meters)



HPS Power Quality Lab

The HPS Power Quality Lab allows customers to experience real time testing of line side HPS power quality products such as transformers, line reactors, active harmonic filters and passive harmonic filters, as well as load side products such as load reactors and different types of dV/dT filters with various cable lengths. HPS power quality products can run at full load using either 10HP, 25HP and 100HP VFD systems and associated motor/load.

HPS Power Quality Lab FAQs

Where is the HPS PQ lab located?

The HPS PQ Lab is located at our Headquarters in Guelph, Ontario, Canada.

What products can be tested in the HPS PQ lab?

The main products that can be tested are line/load reactors, passive harmonic filters, active harmonic filters and dV/dT filters.

How long is a typical session in the lab?

It is expected that a session will typically be completed within 1 hour depending on how many products, sizes and operating conditions are to be addressed.

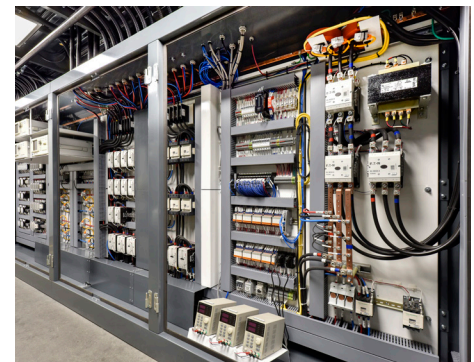
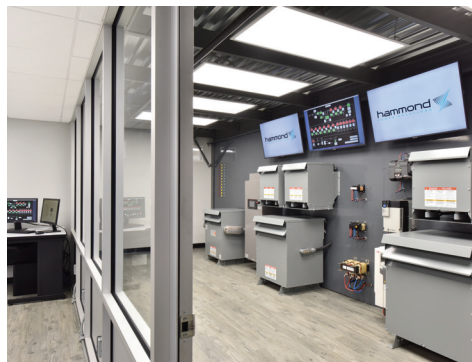

Products That Support Power Quality

HPS has many power quality products which mitigate current and voltage harmonics caused by non-linear loads including rectifiers, variable frequency drives, DC power supplies and E.V. Charging.

HPS power quality products include:

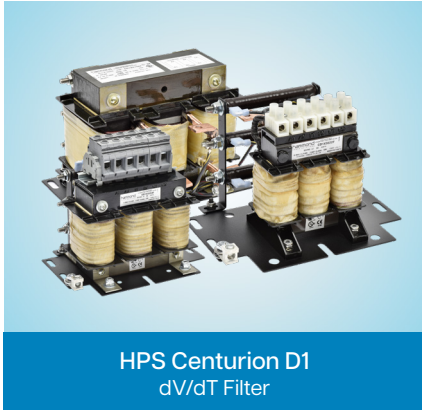



CANADA

Hammond Power Solutions

595 Southgate Drive
Guelph, Ontario N1G 3W6
Tel: (519) 822-2441 | Fax: (519) 822-9701
Toll Free: 1-888-798-8882

sales@hammondpowersolutions.com



UNITED STATES

Hammond Power Solutions

1100 Lake Street
Baraboo, Wisconsin 53913-2866
Tel: (608) 356-3921 | Fax: (608) 355-7623
Toll Free: 1-866-705-4684

sales@hammondpowersolutions.com



MEXICO

Hammond Power Solutions Latin America S.

Av. No. 800,
Parque Industrial Guadalupe
Guadalupe, NL, Mexico, C.P. 67190.
Tel: (819) 690-8000

sales@hammondpowersolutions.com



ASIA

Hammond Power Solutions Pvt. Ltd.

Plot No 6A, Phase -1, IDA,
Pashamylaram, Patancheru (M)
Sangareddy, 502 307, India
Tel: +91-994-995-0009

marketing-india@hammondpowersolutions.com

EMEA (SALES OFFICE)

Hammond Power Solutions SpA

Tel: +49 (152) 08800468

sales-emea@hammondpowersolutions.com

