

# Electronic Exposed TECK® Flush Valves

**TECK®  
COMMERCIAL**



## 81T221HWA

### Exposed Hardwire Operated 1-1/2" Top Inlet Closet Fixture

- Polished chrome plated vandal resistant metal cover with top mounted sensor operated **H<sub>2</sub>OPTICS®** electronics
- Right or left-hand supply installation
- ADA compliant, automatic operation hardwire powered infrared sensor
- Scratch resistant replaceable lens window
- Supplied with an advanced infrared sensor activated flush system that uses precise user distance measurements along with a bowl length setting to activate the correct flush for each usage
- Hardwire adaptor 24VAC to 6VDC converter (supplied)
- Vandal resistant copper tube conduit
- Optional 24 hour automatic flush factory set to OFF
- Set-up sensor range adjustment indicator lights
- 24 VAC input, 6 second arming delay
- Electronic operated non-hold-open **metal** override button with 5 second lockout
- (110 to 24 VAC Transformer not included. See selection below for additional part number.)
- Quiet action, TECK® exposed diaphragm flush valve
- Chloramine resistant diaphragm
- Forged brass diaphragm retainer
- Renewable seat
- Polished chrome plated body
- External water conserving flush adjustment**, factory set to 6 litre (1.6 gal.) (except -48 and -6 models)
- 1" FIP/Copper sweat inlet adaptor**, angle check stop with protecting cap
- Adjustable 121mm (4-3/4") plus or minus 11mm (7/16") inlet/valve outlet centers
- Vacuum breaker
- Cover tube, stainless steel wall flange, spud flange, concealed spud nut, and 610mm (24") outlet tube
- Recommended water supply:**  
Minimum flowing pressure – 25 psi (172 kPa)  
Minimum flow rate – 25 gpm (95 L/min)
- Note:** Models 81T221BTA and 81T221HWA are designed for retrofits with water supply rough-in 24" (610mm) above top of water closet. For new installations, 81T201BTA and 81T201HWA are recommended.

## 81T221HWA-6

Same as 81T221HWA, but **Not Field Adjustable**

## 81T221HWA-48

Same as 81T221HWA, but factory set to 4.8 litre (1.27 gal.), **Not Field Adjustable**



### Available Options for Field Conversion

- 061047A Hardwire with Battery Backup**  
See DSP-BB for detailed specification.

### Approvals:

- IAPMO listed to ASSE 1037/ ASME A112.1037/ CSA B125.37
- Indicates compliance to ICC/ANSI A117.1

(Contact Delta Representative for State and/or Local Approvals.)

Patented



### Engineer/Architect Approval

Model Specified:

Approval:

Date:



**81T221HWA**

✓	TRANSFORMERS	
	<b>060704A</b>	110 to 24VAC Class II 20VA (for up to 5 Electronic Valves)
	<b>060771A</b>	110 to 24VAC Class II 20VA (for up to 10 Electronic Valves)

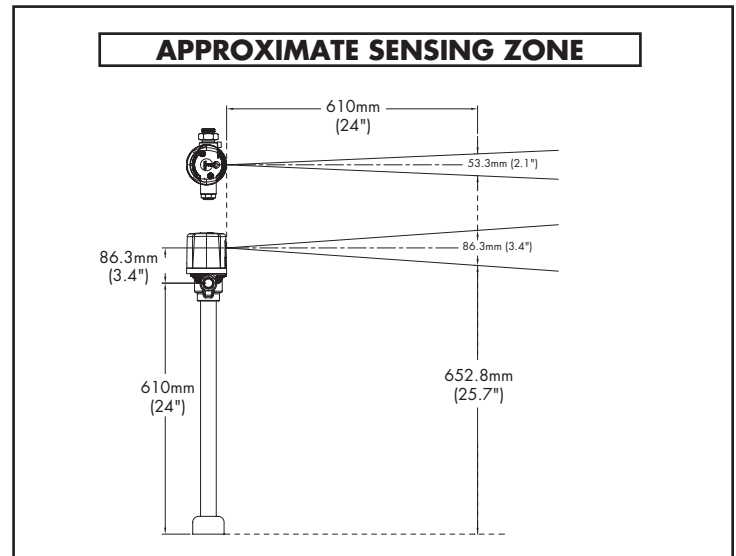
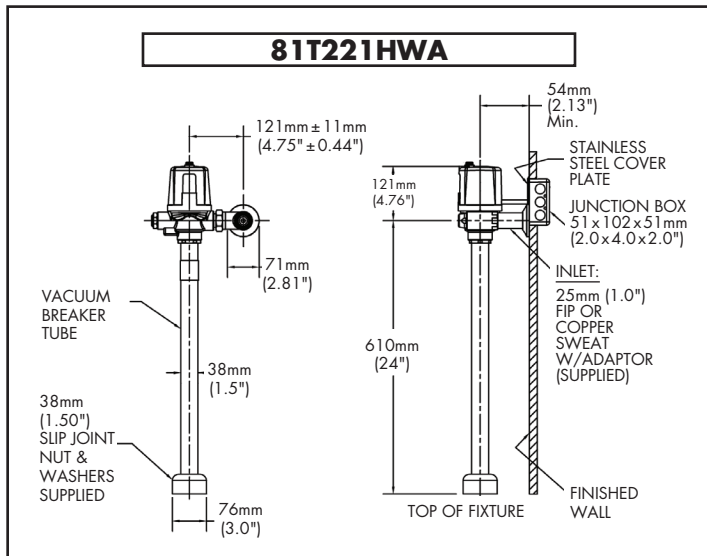

Note: For high and low pressure applications, please see page FEA-81T High Water Pressure note for more details.

Verify flow requirements with bowl manufacturer.

Note: Measurements may vary ± 6mm (0.25")

Refer to [www.specselect.com](http://www.specselect.com) for individual models.

Note: Use this page as a product submittal sheet.