

Heat Link[®]

TWH070P, TWH070XP

Tankless Water Heater Panels

Installation, Operation, and Maintenance Manual

TWH070P

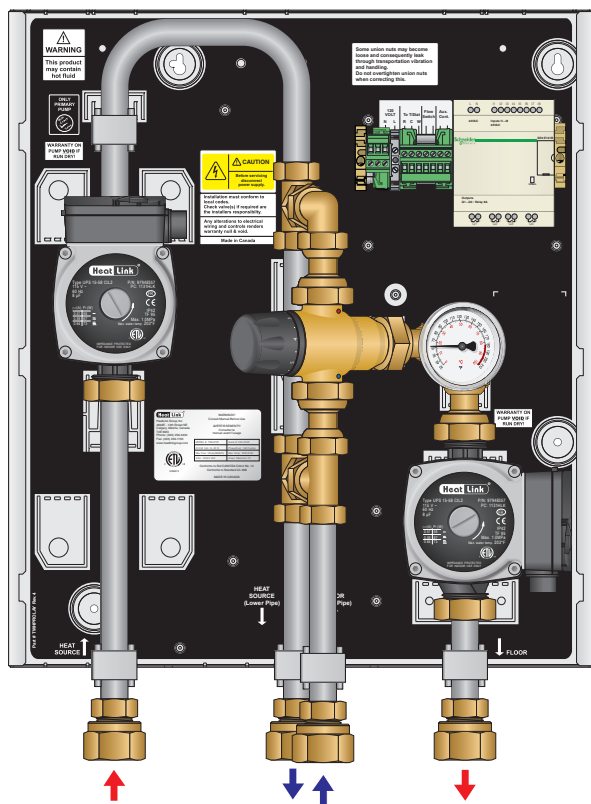

TWH070XP

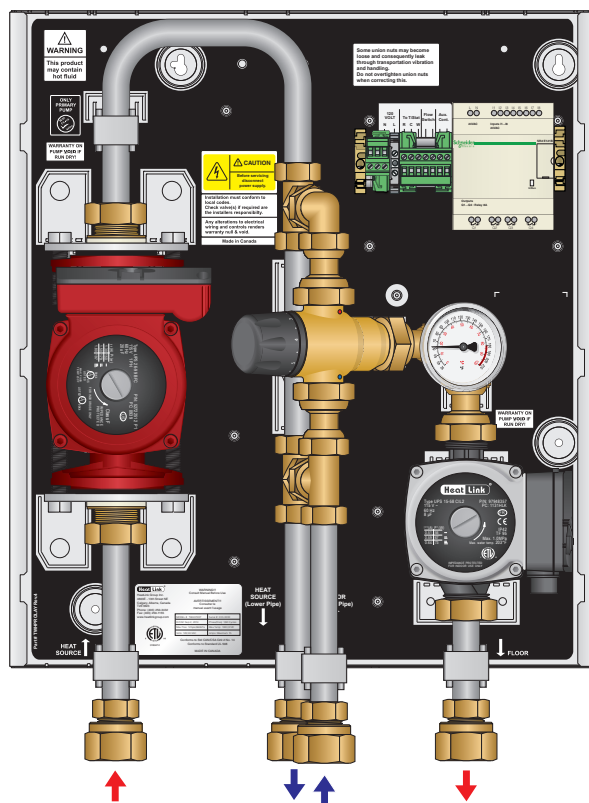

MECHANICAL ROOM IN A BOX[™]

L6TWH000

Table Of Contents

Warnings.....	3
Tools Needed	3
Function.....	4
Unpacking.....	4
Panel Components	5
Specifications.....	6
Dimensions.....	7
Panel Component Specifications	7-9
Valve Adjustments	9
Mounting.....	10
Piping Hookup	11
Fill and Purge	12
Panel Wiring	13
Panel Control Sequence.....	14
DHW Priority Switch Installation.....	15
Troubleshooting	16-17
Maintenance	17
Schematics	
Mechanical	18-25
Electrical Rough-in	26-27
Electrical Detail	28-34

Warnings

The zone control panel is for indoor use only and must be installed by a qualified installer/service technician. This product must be installed and operated in strict accordance with the terms set out in this manual and in accordance with the relevant requirements of the Local Authority Having Jurisdiction. Failure to comply will result in a void of warranty, and may also result in property damage, serious injury, or death.

Servicing

Prior to commencing installation of this panel it is necessary to read and understand all sections of this manual. The symbols below are used throughout this document to ensure proper operation of the panel, and your safety. Please pay attention to these symbols.



Warning
Possible Hazard



Warning
Live Power



Warning
Hot Pipes



Warning
Treated Water



In order to avoid injury or death, switch off the power to the panel prior to inspecting or making connections to the terminal strip.

Disclaimer

HeatLink Group Inc. shall not be responsible for errors in its brochures or printed materials. HeatLink Group Inc. reserves the right to alter its products at any time without notice, provided that alterations to products already on order shall not require material changes in specifications previously agreed upon HeatLink Group Inc. and the Purchaser. All trademarks in this material are property of the respective companies. HeatLink and the HeatLink logotype are trademarks of HeatLink Group Inc. All rights reserved.

Tools For Installation

- Level
- Screwdriver or power drill
- Flat head bit
- Phillips head bit # 2
- 2 adjustable wrenches (or 2× 30mm wrenches and 2× 40mm wrenches)

Function

This panel can provide mixing, distribution, and zoning for a wide variety of hydronic heating applications. The effectiveness of the system is dependant on the system being designed and installed correctly. Proper consideration of factors such as BTU loads, outdoor design temperature, indoor design temperature, room set-point temperature(s), differential fluid temperatures, head loss, flow rates, and transfer capacities of the heat emitters is critical. Once these factors have been considered and the system requirements determined, these can then be evaluated and compared to the zone control panel capabilities (refer to pages 5-9).

Note: This panel does not regulate or monitor the operating safety limit temperatures of the fluid leaving the heat source.

Unpacking

- Step 1** Examine carton for any damage that may have occurred during shipping. If damage is visible notify your courier and supplier immediately.
- Step 2** Open the carton by removing the staples.
- Step 3** Remove the cardboard spacers from the carton, then remove the panel from the carton. Lift the panel by the base, not the enclosure.
- Step 4** There are 2 screws holding the enclosure in place during shipping. They are located at the top left & right of the panel base. Remove these 2 screws.
- Step 5** Remove the enclosure from the panel by sliding it upwards until it stops, then gently pulling outwards off.



- Step 6** Verify the following items:
- (4) Mounting screws
 - (4) $\frac{3}{4}$ " MBSP \times 1" FNPT adapters
 - (6) $\frac{3}{4}$ " rubber washers (2 spares)
 - (2) 1" rubber washers (spares)
 - (1) 24V(ac) 20VA plug-in transformer

Panel Components

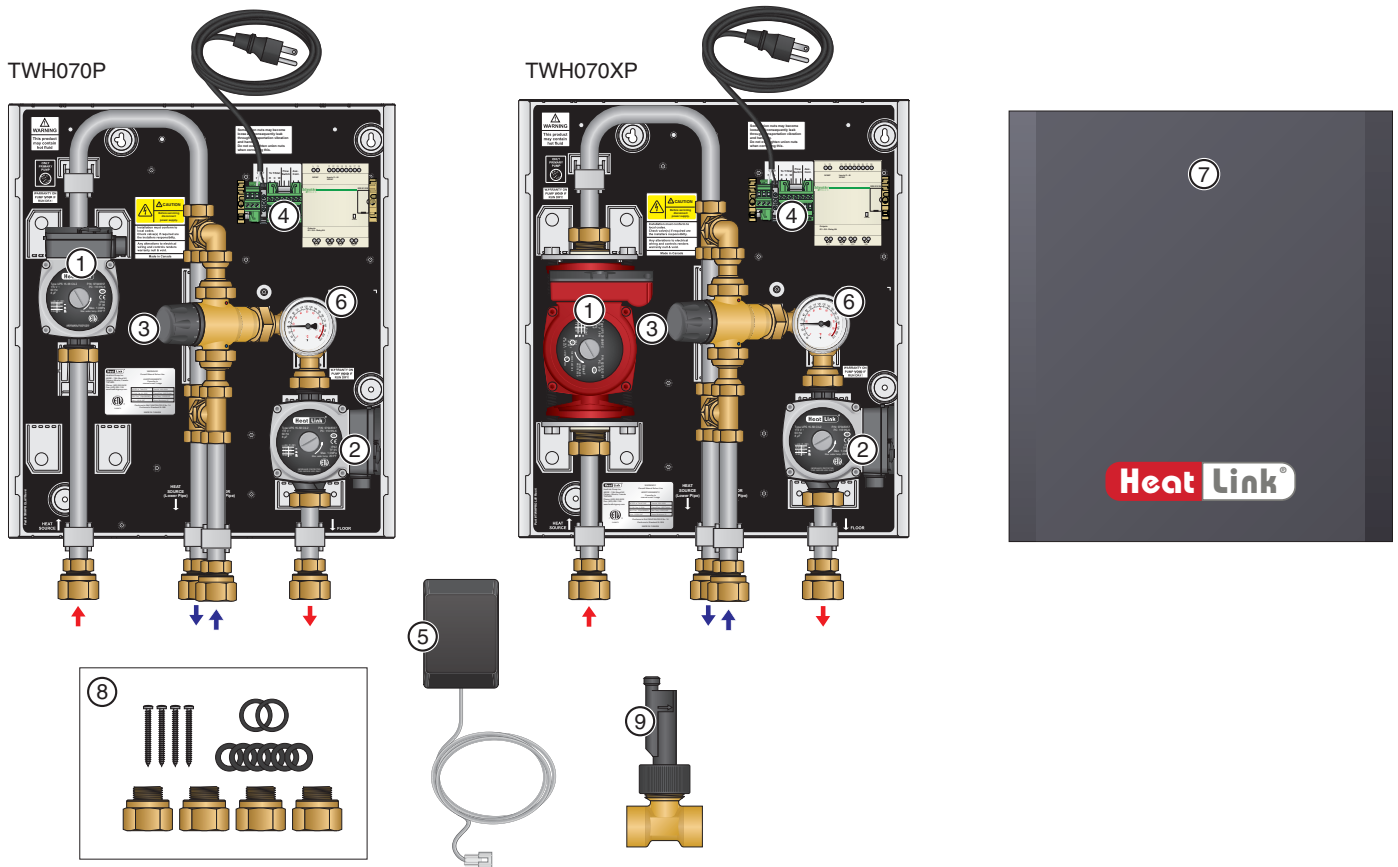

#	Component	Part Number	
		TWH070	TWH070XP
①	Primary Circulator	PUMP1558	PUMP2699BR
②	Secondary Circulator	PUMP1558	PUMP1558
③	Thermostatic Mixing Valve	–	–
④	PLC (Programmable Logic Control)	–	–
⑤	24V(ac) 20VA Plug-in Transformer	PLINTR20VA	PLINTR20VA
⑥	Thermometer	76940	76940
⑦	Enclosure	n/a	n/a
⑧	Accessory Pack	ACCTWH	ACCTWH
	3/4" Washer	WHTWSH34	WHTWSH34
	1" Washer	NTRWSH1	NTRWSH1
⑨	Flow Switch for DHW Priority (optional, sold separately)	FLWSWTCH	FLWSWTCH

Specifications

	TWH070P	TWH070XP
Listing	cETLus	
Conforms to	CAN/CSA-C22 No.14, UL508	
Dimensions	18.25"H x 16.25"W x 8"D	
Nominal panel output	70,000 btu/hr	70,000 btu/hr
Primary nominal flow	4.0 US gpm @ 35°F ΔT	4.0 US gpm @ 35°F ΔT
Primary nominal pressure drop outside of panel	14 ft	24 ft
Secondary nominal flow	7 US gpm @ 20°F ΔT	7 US gpm @ 20°F ΔT
Secondary nominal pressure drop outside of panel	4 ft	4 ft
Max ambient temperature	120°F	
Max water temperature	200°F	
Min required flow for correct temp control	1.3 US gpm (5 L/min)	
Power supply: pre-wired	110 V(ac)	
Primary circulator	Non-ferrous, Grundfos UPS15-58CIL2	Non-ferrous, Grundfos UPS26-99BFC
Secondary circulator	Non-ferrous, Grundfos UPS15-58CIL2	Non-ferrous, Grundfos UPS15-58CIL2
Auxiliary terminal	Yes, dry contacts, max. load 10A	
DHW priority	Optional @ ~0.5 US gpm DHW flow	
Temperature control method	1" 3-Way thermostatic	
Temperature control range	100°F - 145°F	
Valve Cv	3.0	
Piping	¾" 304 Stainless steel tubing	
Piping connections	1" FNPT	
DHW priority switch connection	½" FNPT (FLWSWTCH optional)	
Backplate	Galvanized steel	
Enclosure	Powder coated steel	

TWH Series FT HD Outside of Panel

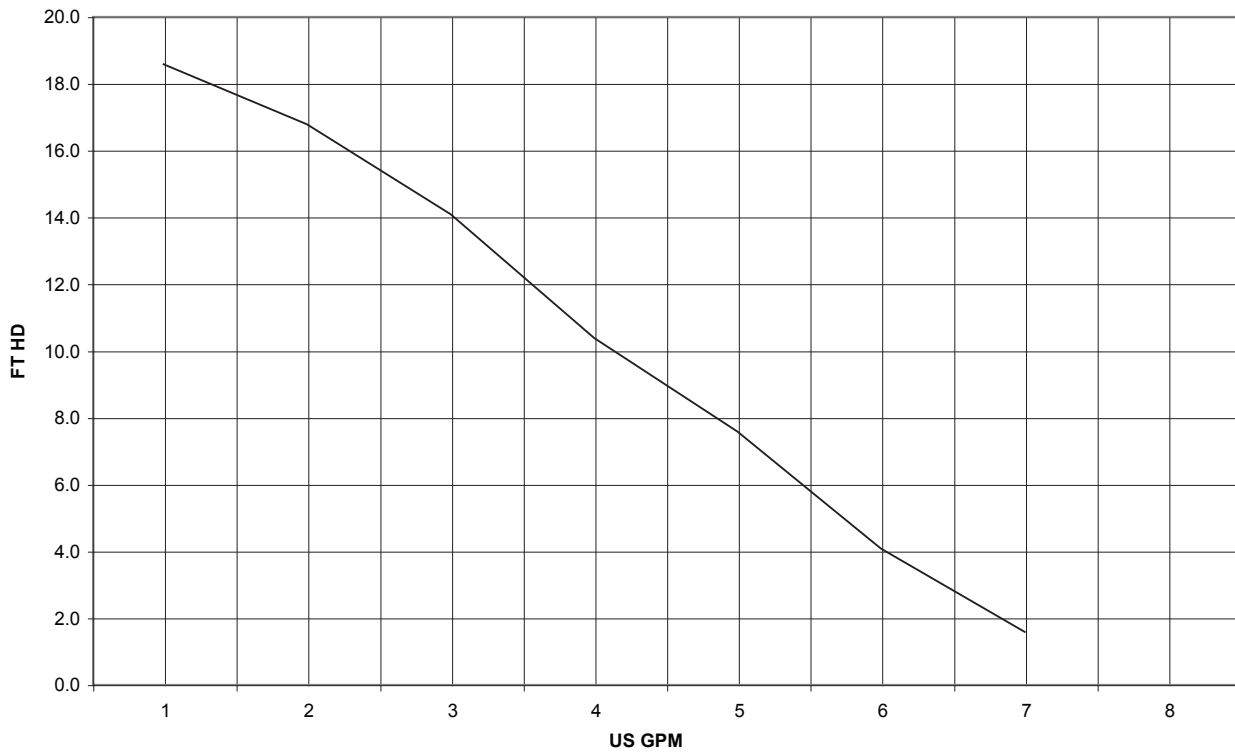

Dimensions

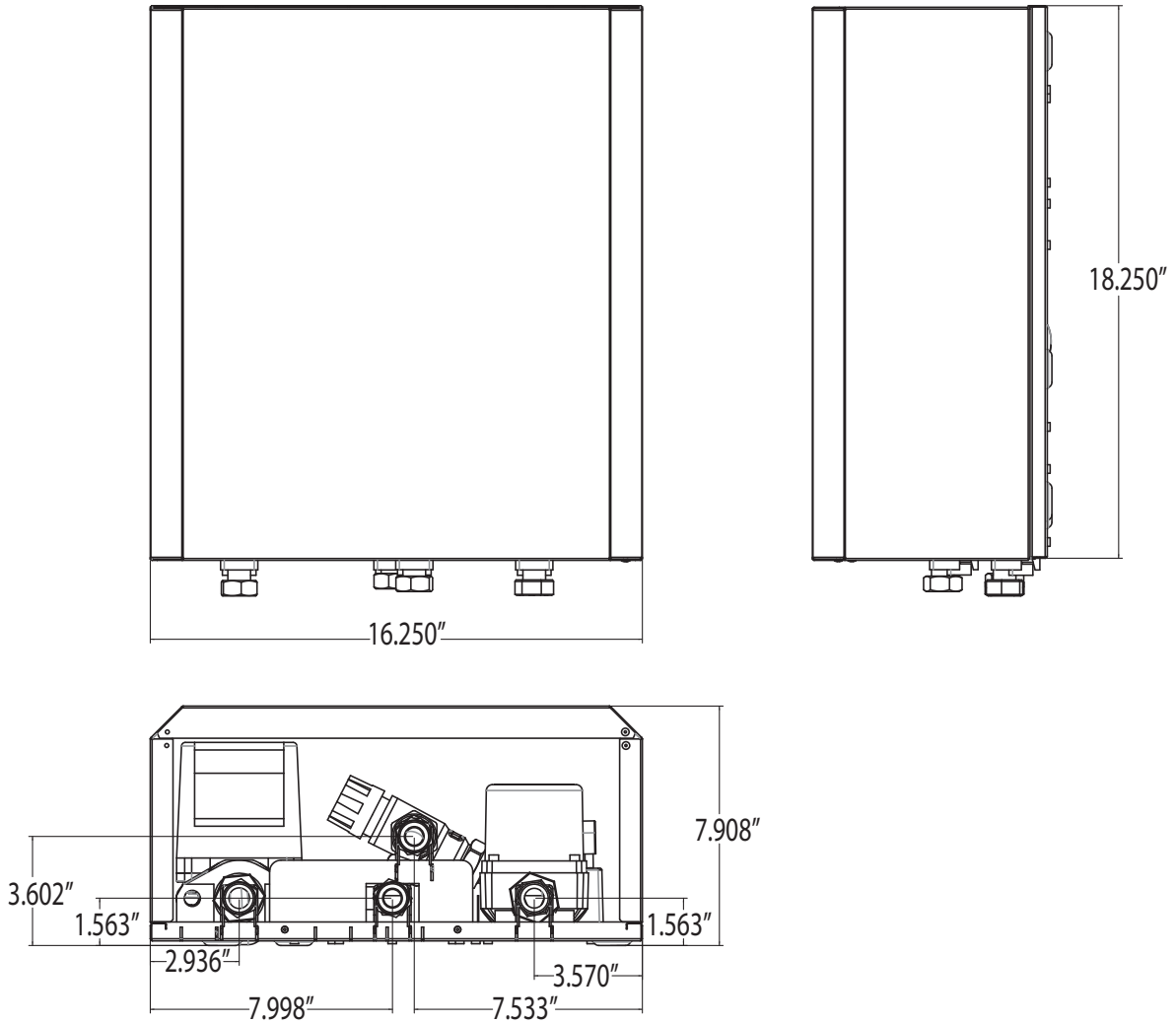

Panel Component Specifications

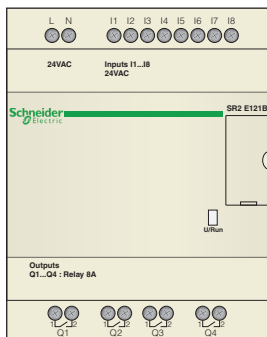

PLC (Programmable Logic Control)

This module provides the control and switching for the panel.

Circulators

The circulators moves the heated fluid through the hydronic system when there is a call for heat from the thermostat. Primary pump on the TWH070XP is a UPS26-99BFC.

Specifications:

- The following pump curves apply.

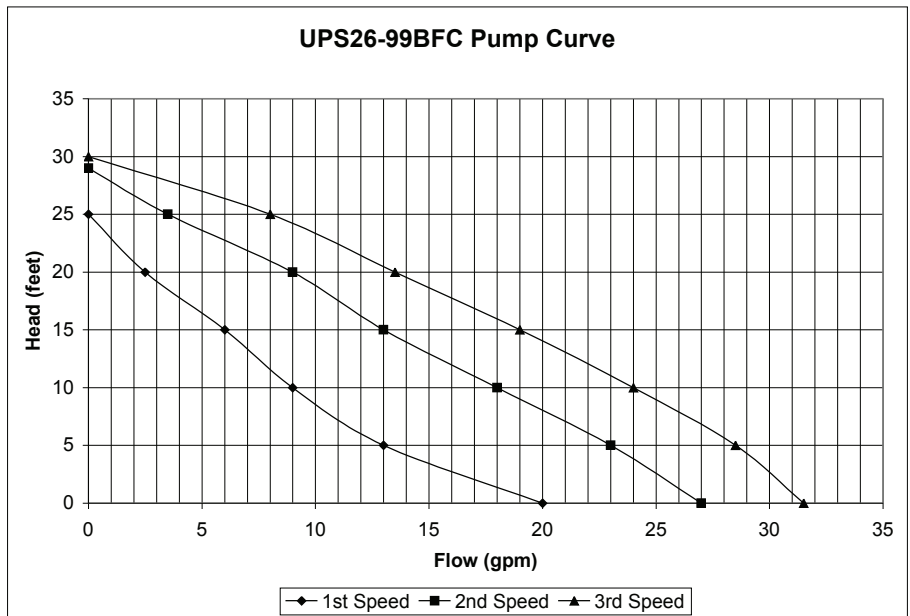
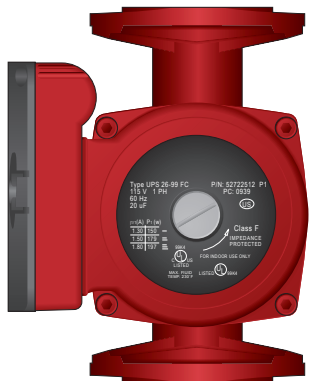
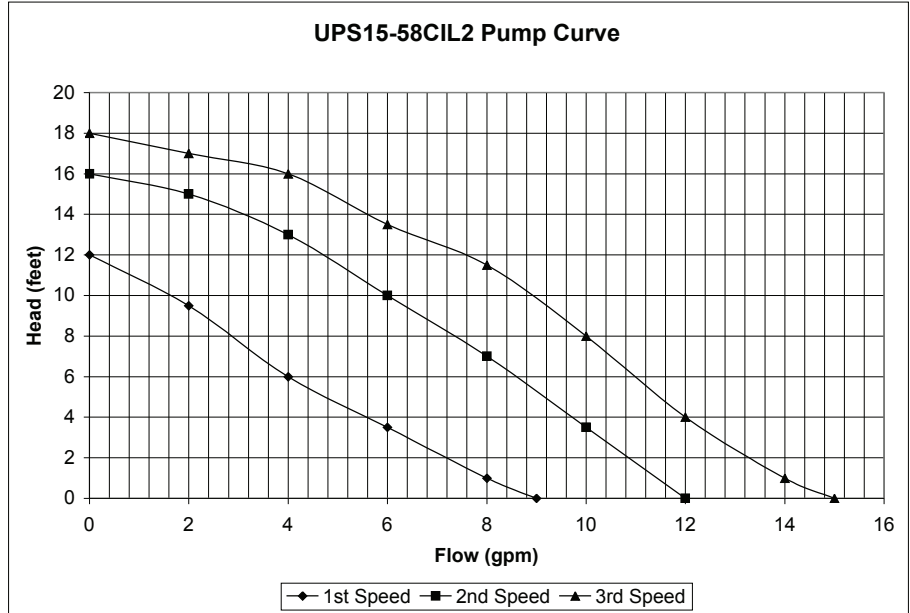
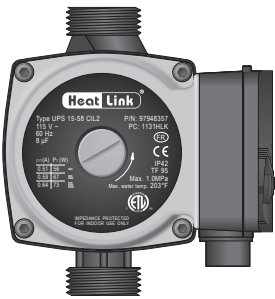

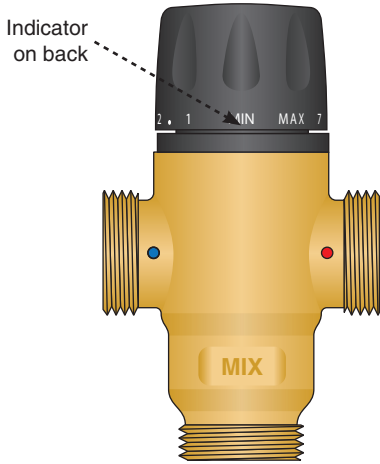

3-Way Thermostatic Mixing Valve (TMV)

The TMV controls the temperature of the hydronic system via a self regulating thermostat.

Materials - Body: Low-lead brass

Setting the TMV

The indicator for the valve is located at the base of the knob on the back. The mixed (desired) temperature is a function of the TMV setting.

See the below chart to determine the proper setting for you system. After allowing the system to run for a short period, verify the setting and adjust if necessary.

Unit	Mixed Fluid Temperature								
	Min.	1	2	3	4	5	6	7	Max.
°F	81	90	100	111	120	127	136	145	152
°C	27	32	38	44	49	53	58	63	67

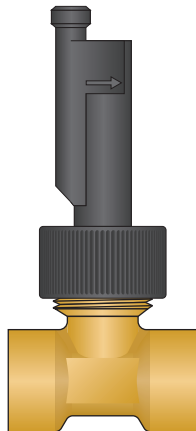

**Flow Switch for DHW Priority (FLWSWTCH)
(optional, sold separately)**

The electronic flow indicator provides DHW priority when the DHW flow rate reaches a factor pre-set level (approx. 0.5 US gpm). Must be piped in downstream of panel (see schematic on page 15).

Mounted separately from the panel (see page 15).

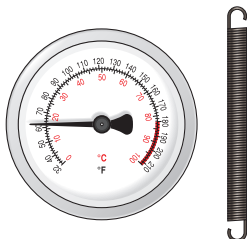

Thermometer (76940)

The pipe mounted thermometer reads the supply fluid temperature.

Specifications:

- Temperature range of 32-210°F (0-100°C).

Mounting

Prior to mounting the panel, ensure the wall is capable of supporting the weight of the panel.
Ensure that a 115V receptacle is within reach of the 6-foot cord and plug and 24V plug-in transformer.

Step 1 Determine the locations and distance between the wall studs. With a level at a minimum height of 4' from the floor draw a straight line on the wall and mark the stud locations.
If the panel cannot be secured directly to the studs, or suitable backing boards, plywood may need to be installed behind the panel to properly secure it in place.

Step 2 Screw two of the supplied mounting screws into the wall studs (or backing plywood) 2" from the top of desired height, and 10-1/2" apart, leaving 1/4" of screw out from the wall.

Step 3 Lift and place the panel onto the mounting screws.

Step 4 Screw the two remaining mounting screws into the holes at the bottom of the panel and tighten the top two screws.

Step 5 Before replacing the enclosure, refer to pages 12-14 for fill and purge, and proper wiring instructions.

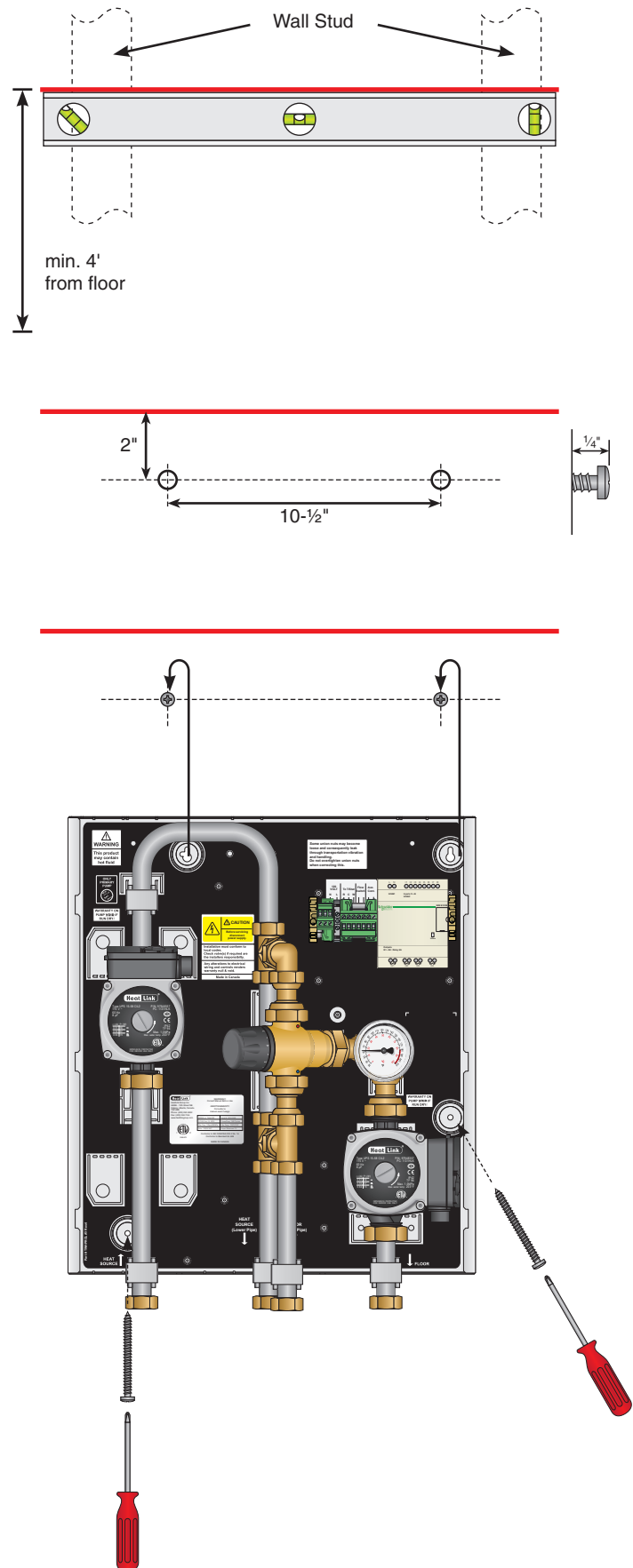

Piping Hookup

Step 1 Before making any connections, identify the required connections to and from the panel. Adapters are $\frac{3}{4}$ " M BSPP \times 1" FNPT, and must use the supplied adapters and rubber washers.

Step 2 Connect all adapters.

1. Connect MNPT adapter (E) to copper pipe or tubing (F).
2. Screw supplied M \times FNPT adapter (D) onto (E) using appropriate thread sealant.
3. Take assembly (D)(E)(F) and place rubber washer (C) on flat surface of (D).
4. Without disturbing rubber washer (C), place assembly against flanged stainless steel pipe (B).
5. Slide nut (A) over adapter (D) and first finger tighten nut. Then, using two 30mm wrenches, tighten the nut **taking care not to overtighten the nut**, as this will damage the rubber washer.

Step 3 See page 15 for instructions on connecting the optional Flow Switch for DHW Priority (FLWSWTCH).

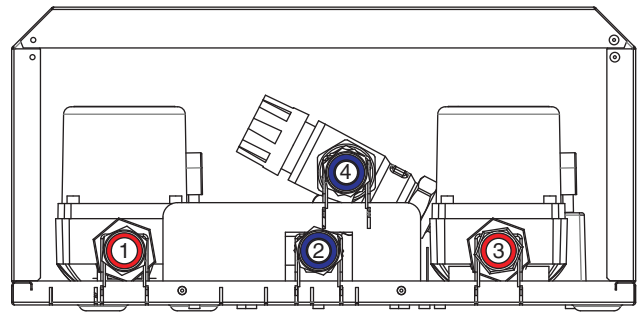

- ① Primary Supply
- ② Primary Return
- ③ Secondary Supply
- ④ Secondary Return

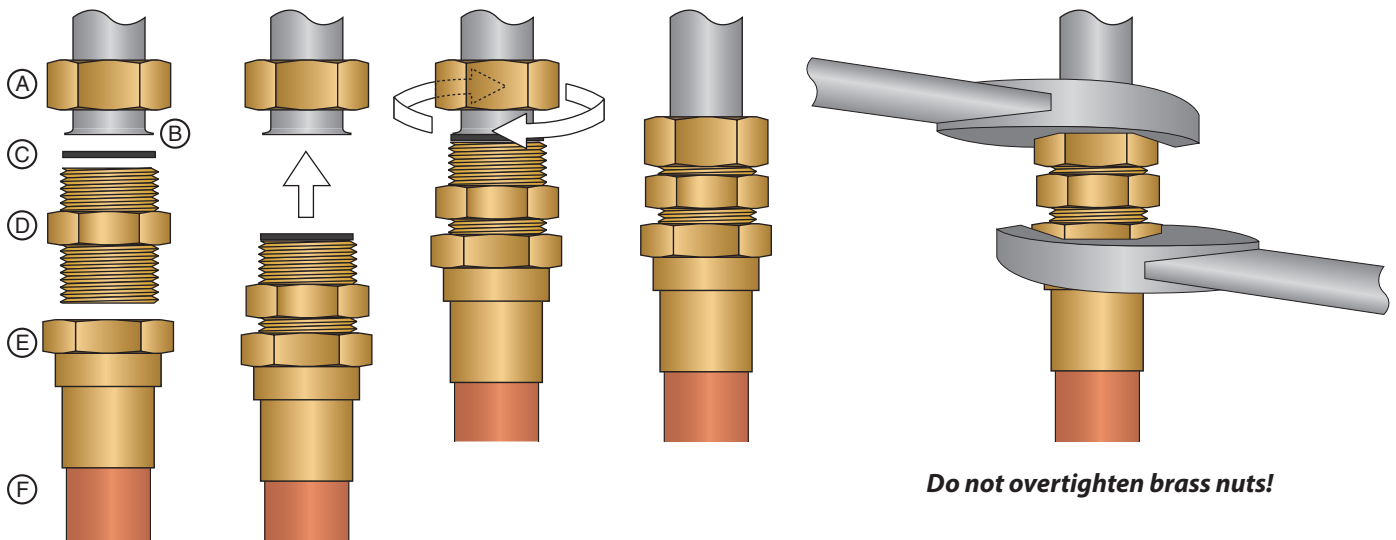

Note: Use precautions when soldering or applying heat within 16" of the panel.

Fill And Purge

The following steps are recommended in order to fill the panel with water and purge entrained air once piping is completed, and before activation of the panel.



The discharged system fluid from the fill and purge process is not for consumption or washing.

Note: Additional purging steps may be required for the rest of the hydronic system.

Note: Isolation and drain valves are not included with the panel, but are necessary to properly fill and purge the panel, and to isolate the panel for service.

- Step 1** Ensure the panel is **not** plugged in.
- Step 2** Adjust the thermostatic mixing valve to a position of "Max." (see page 9).
- Step 3** Fully close valves (A), (B), (C), (D), and (F). Fully open valve (E).
- Step 4** Attach a purge hose (not included) to (E) and a fill hose (not included) to (F). Open valve (F).
- Step 5** When exiting water from (E) is free of bubbles, close valve (E), then valve (F).
- Step 6** Remove hoses from drain valves and full open valves (A), (B), (C), and (D).
- Step 7** Check for leaks at connections. If any leaks are found, use a back-up wrench and carefully tighten until leak stops. **Do not overtighten.**
- Step 8** Readjust the setting of the thermostatic mixing valve to provide a proper mixed fluid temperature to the hydronic system (see page 8).

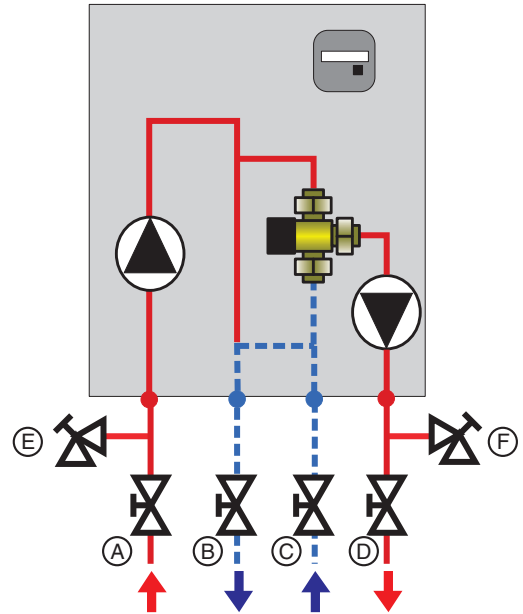

Panel Control Sequence

1. When the power cord ① and transformer ② are plugged in, the PLC will start operation and the RUN/STOP light will turn green. (If the RUN/STOP light is red contact your HeatLink representative.)
2. When a thermostat calls for heat, its internal 24V contacts close, the auxiliary terminals close, and both circulators ③ turn on.
3. As the circulators move fluid through the panel the thermostatic mixing valve adjusts the fluid temperature based on the user settings (page 8).
4. When the requirements of the thermostat are met, the internal contacts of the thermostat open, the auxiliary contacts open, and the circulators stop.
5. Both the primary and secondary circulators are activated once every 24 hours, for 15 minutes, to ensure that potable water in the piping is not stagnant.

Note: If the FLWSWTC optional DHW priority flow switch ④ is installed and the DHW flow is above the factory setting for this device, the primary circulator stops and the auxiliary contacts open. When the DHW flow drops below the factory setting the panel resumes normal operation.

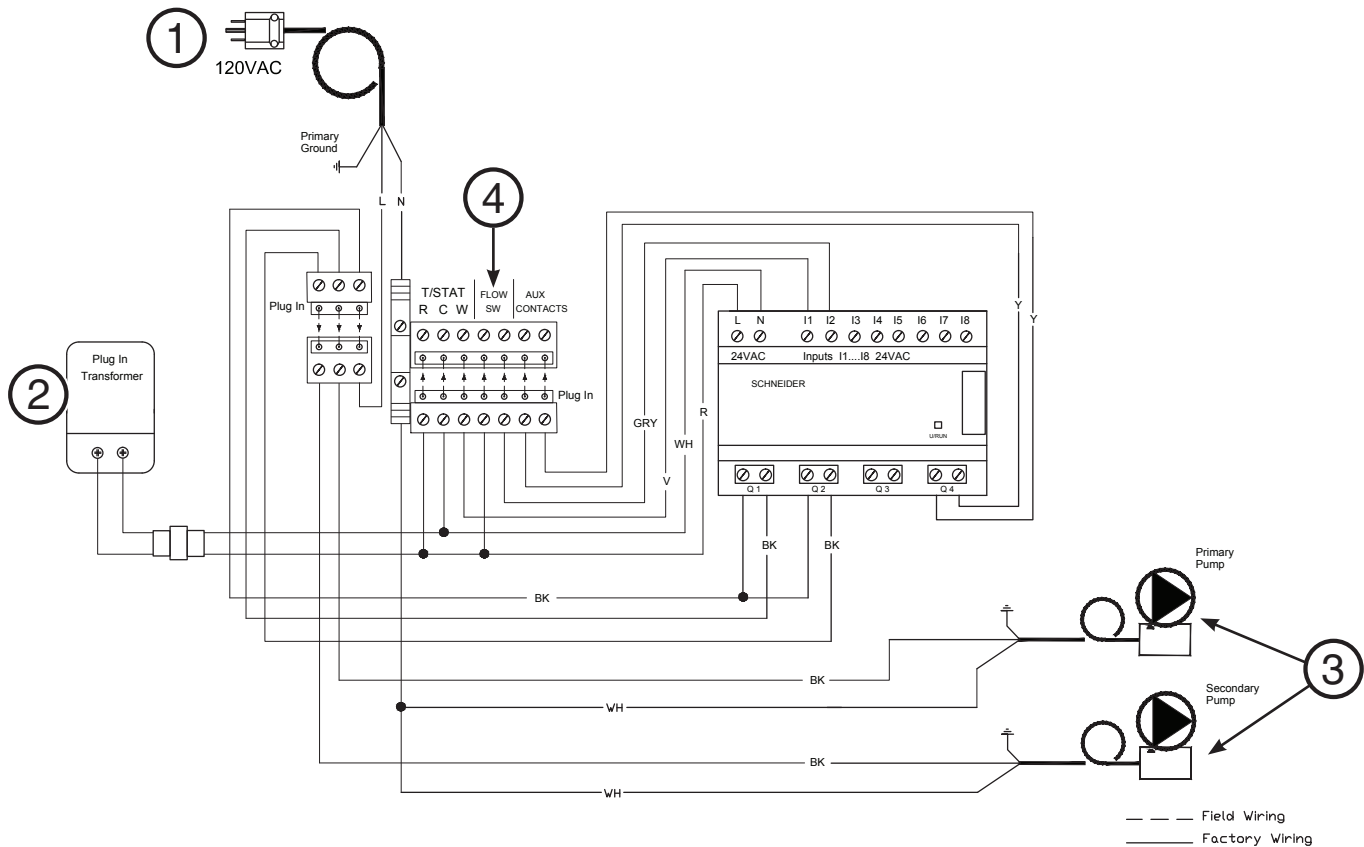

Flow Switch for DHW Priority (FLWSWTCH) Installation (optional, sold separately)

Installation Notes:

- Makes sure the cable to the flow switch isn't under tension.
- Clean the pipe system in which the flow switch is to be installed and remove any magnetic particles, e.g. welding residue.
- The straight in- and outlet pipe (in front of and behind the flow switch) has to be at least 2-½" (65 mm).
- The flow switch should be installed in an "upright standing position" in horizontal pipework.
- The switch should only be installed in a vertical position, deviation max. 45°.
- Make sure that there are no external magnetic fields or large ferromagnetic bodies in the immediate vicinity of the flow switch, since these can impair device functioning.
- Screw on the union plastic nut with a maximum torque of 8 Nm.
- To prevent overheating when soldering near the flow switch, the flow switch (body with paddle system) and the o-ring must be removed from the pipe section.

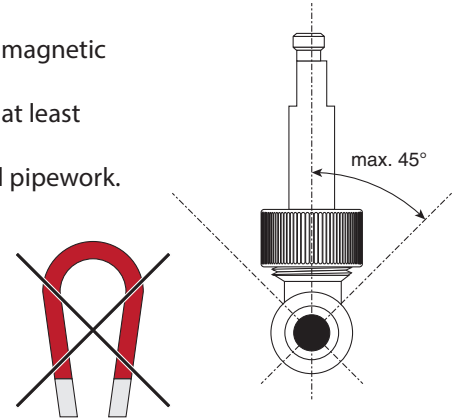

- Step 1** DHW connectors are ½" FNPT. Using appropriate thread sealant and fittings, connect the water heater output to the input on the flow switch; and house hot water system to output on flow switch. The straight in- and outlet pipe (in front of and behind the flow switch) has to be at least 2-½" (65 mm). Observe flow direction when making connections. Be sure to connect the DHW priority *downstream* from the panel (see schematic below).

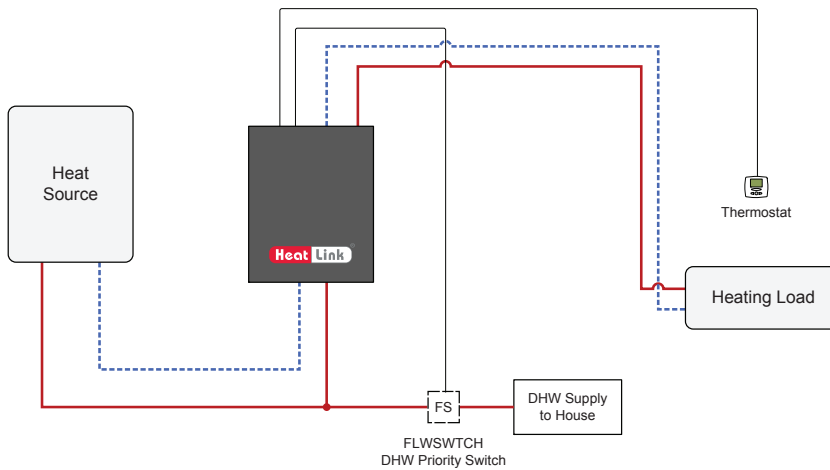
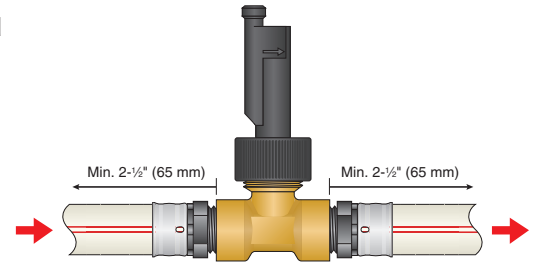

- Step 2** Disconnect power from the panel. Remove the terminal header of the wiring harness from the flow switch. Connect the flow switch wires to the flow switch terminals.

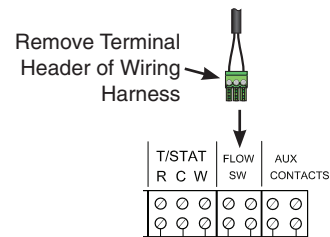

Troubleshooting

Problem	Check / Verify	Possible Cause
Low Temperature Within Room	Misplacement of thermostat location within room.	Make sure thermostat is not being influenced by an additional heat source, such as lighting or air duct.
	Low temperature setting of the thermostat.	Adjust the temperature setting on thermostat.
	The system fails to turn on if the thermostat is set to high setting	Thermostat may be out of calibration or defective. Replace thermostat.
	The electronic actuator fails to open during a call for heat	The electronic actuator may be improperly seated or may be defective. Replace if necessary.
	Low supply mixed fluid temperature.	Adjust the thermostatic mixing valve to the appropriate setting.
	Wiring from heat source to panel.	Check that the wiring is done properly. Consult qualified electrician prior to alteration of wiring between heat source and panel.
	Output of heat source is unable to meet demand of heating system.	Compare output of heat source to the requirements of the heating system.
	Circulator is not on during a call for heat. (Use a stethoscope or similar device to verify)	The PLC or circulator may be defective.
	When zone valves are installed outside the panel a qualified electrician should verify 24V power is supplied to the thermostats and actuator.	The 24V transformer may have failed. Any zone valves must be opened manually to avoid dead-heading of the circulator.
High Temperature Within Room	Check current setting of the thermostat.	Adjust the temperature setting on thermostat to a lower setting.
	High supply mixed fluid temperature.	Adjust the Thermostatic Mixing Valve to the appropriate settings.
	Installed electronic actuators remain open after the thermostat is satisfied.	An obstruction inside the zone valve is not allowing the actuator to fully close or the thermostat is still calling for heat.

Troubleshooting (continued)

Temporarily create a “permanent” heat demand by installing a jumper between W & R. With a jumper between W & R, the pumps should run and the auxiliary contacts should close.

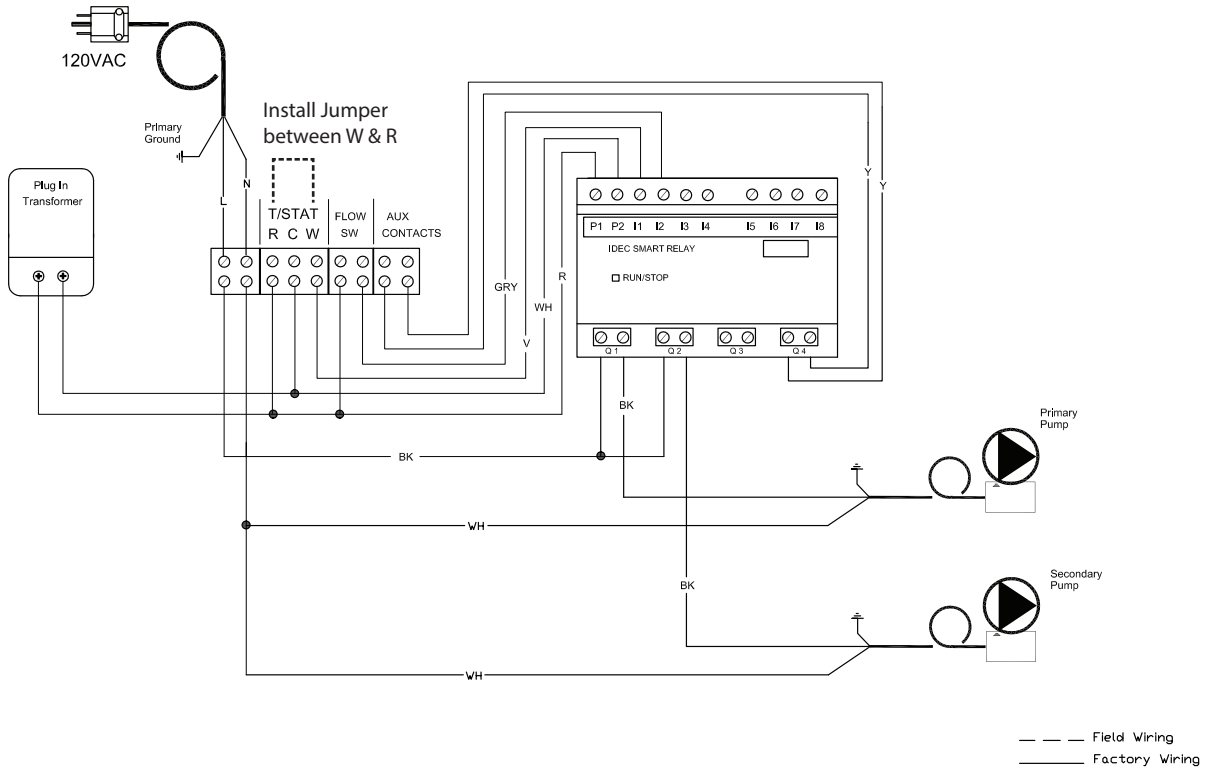

Maintenance

Yearly maintenance should be done on the panel prior to each heating season to ensure the efficient and accurate operation of the panel.

Complete the following check list:

- Raise all thermostats to cause a call for heat within the system. Verify that the circulator starts, via a stethoscope or similar device.
- Confirm that the Auxiliary Contacts close.
- If applicable, verify that each zone valve opens during the call for heat – the actuator should be warm to the touch, the LED will light up (on 5620x models) and the white indicator should rise from the top of the actuator.
- Return all thermostats to a desirable setting.

You are now ready for another heating season with HeatLink.

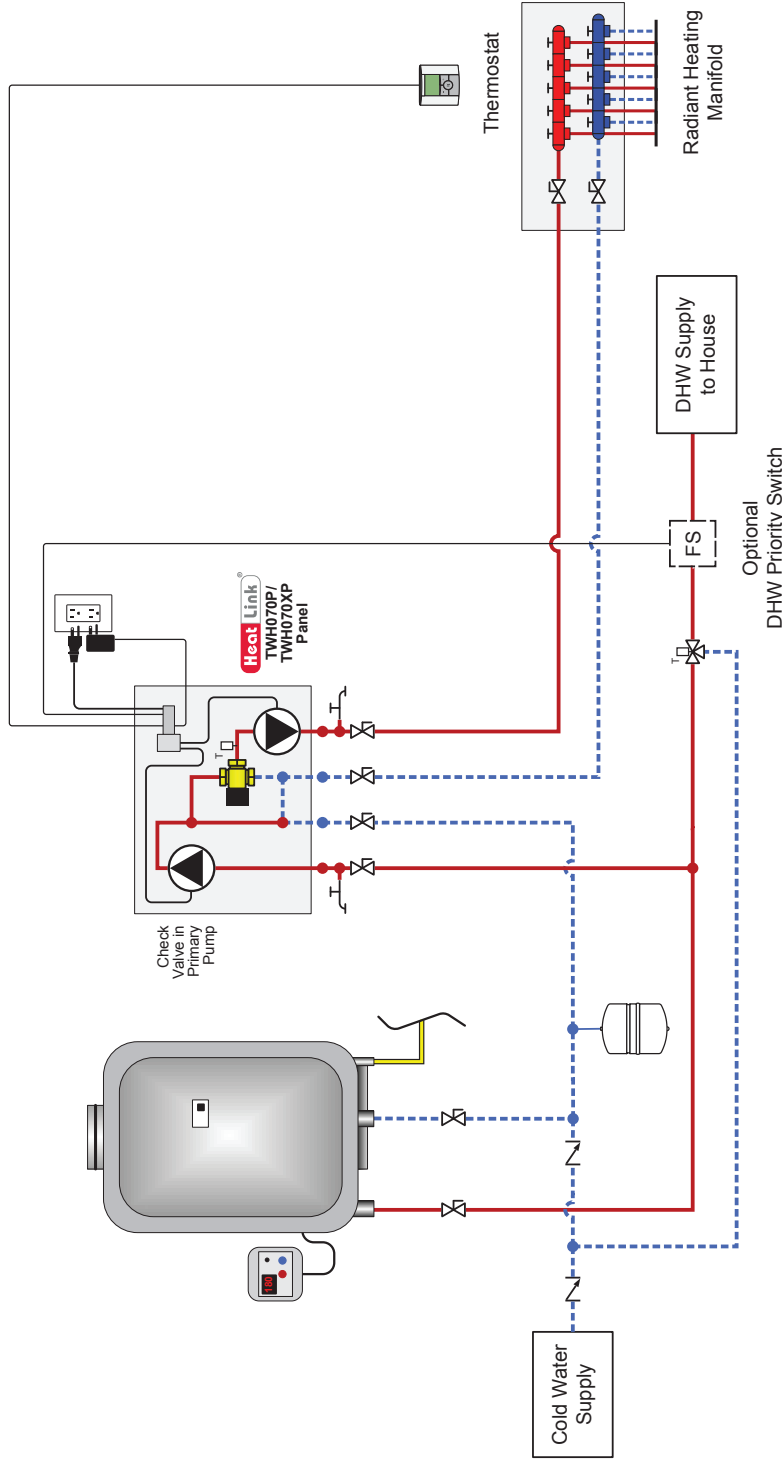

- Notes:**
- Drawings are for HeatLink suggested system layout only! User must determine if system layout will work for their particular application.
 - Air vents, expansion tanks, pressure relief valves, etc. for heat source as per local codes.
 - Use isolation ball valves for all circuits and components.
 - Local codes, regulations, and authorities have final jurisdiction.

Heat Source: Tankless Water Heater
 Panel(s): TWH Series
 Heat Load(s): Radiant Floor Heating – Single Zone
 Date: 2014-09-02

Schematic #: SCH-TWH-M002
 Rough-in wiring see: SCH-MRIB-R001
 Wiring detail see: SCH-TWH-E001

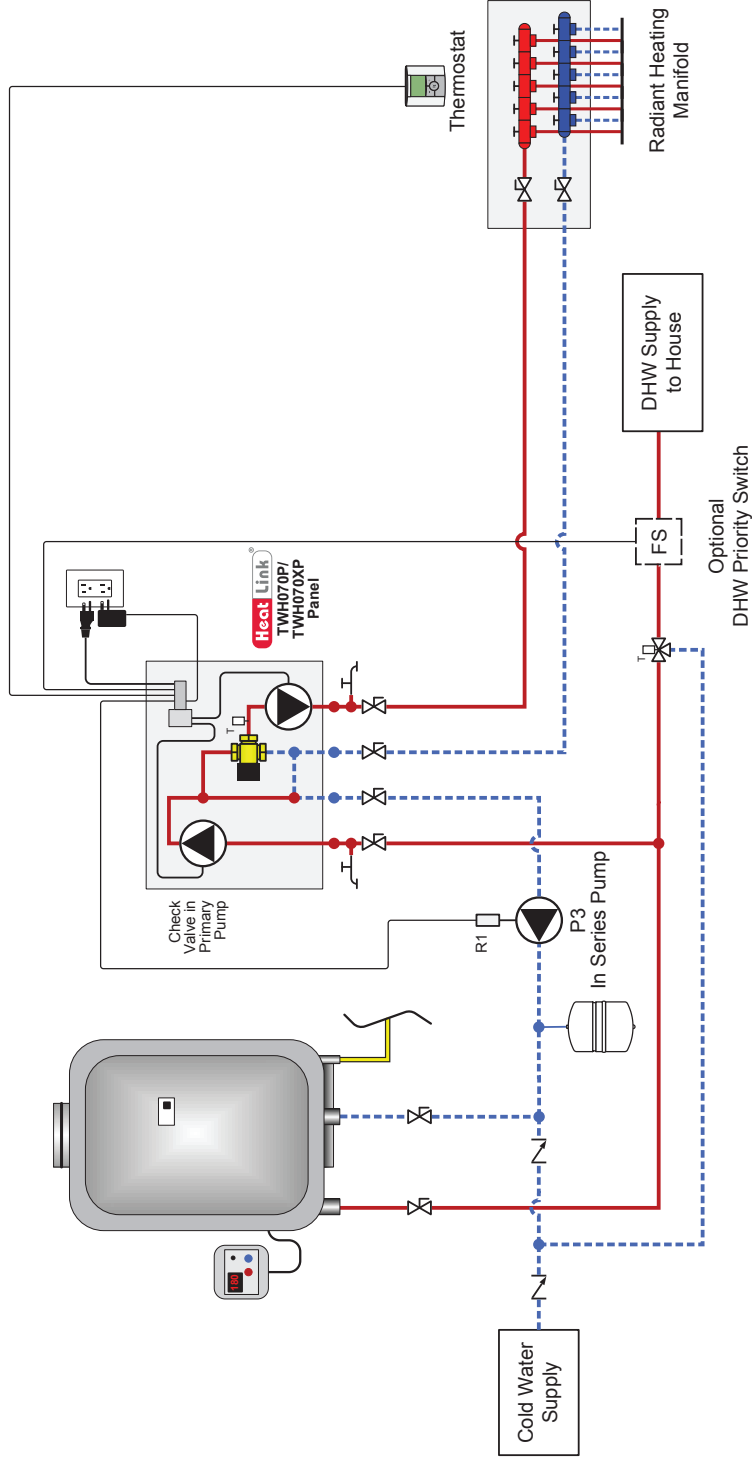

- Notes:**
- Drawings are for HeatLink suggested system layout only! User must determine if system layout will work for their particular application.
 - Air vents, expansion tanks, pressure relief valves, etc. for heat source as per local codes.
 - Use isolation ball valves for all circuits and components.
 - Local codes, regulations, and authorities have final jurisdiction.

Heat Link
 www.heatlink.com
 1-866-661-5332

Heat Source: Tankless Water Heater with High Flow Resistance
 Panel(s): TWH Series
 Heat Load(s): Radiant Floor Heating – Single Zone
 Date: 2014-09-02

Schematic #: SCH-TWH-M004
 Rough-in wiring see: SCH-MRIB-R001
 Wiring detail see: SCH-TWH-E004

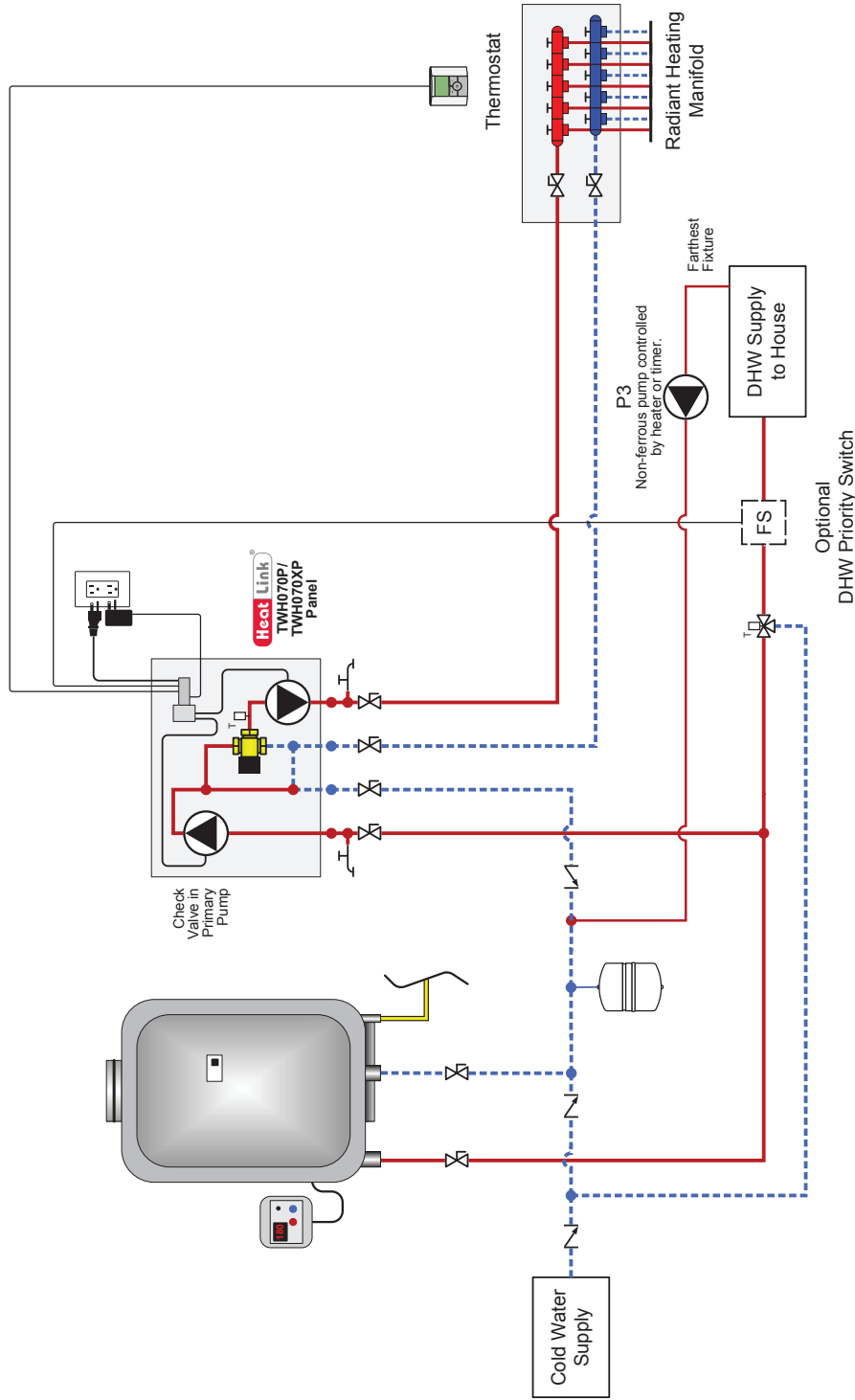

- Notes:**
- Drawings are for HeatLink suggested system layout only! User must determine if system layout will work for their particular application.
 - Air vents, expansion tanks, pressure relief valves, etc. for heat source as per local codes.
 - Use isolation ball valves for all circuits and components.
 - Local codes, regulations, and authorities have final jurisdiction.

Heat Link
 www.heatlink.com
 1-866-661-5332

Heat Source: Tankless Water Heater
 Panel(s): TWH Series
 Heat Load(s): Radiant Floor Heating – Single Zone

Date: 2014-09-02

Schematic #: SCH-TWH-M005

Rough-in wiring see: SCH-MRIB-R001

Wiring detail see: SCH-TWH-E005

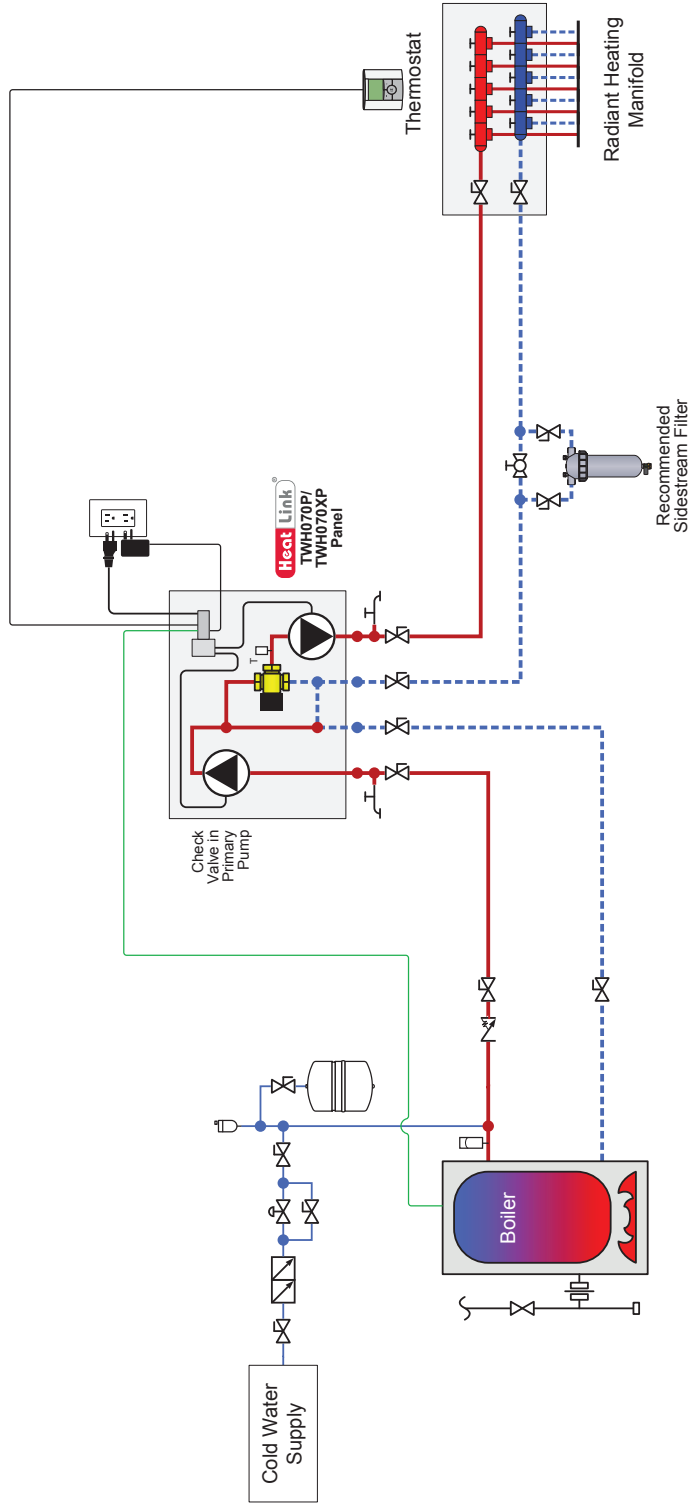

Notes:

- Drawings are for HeatLink suggested system layout only! User must determine if system layout will work for their particular application.
- Air vents, expansion tanks, pressure relief valves, etc. for heat source as per local codes.
- Use isolation ball valves for all circuits and components.
- Local codes, regulations, and authorities have final jurisdiction.

Heat Link
 www.heatlink.com
 1-866-661-5332

Heat Source: Boiler
 Panel(s): TWH Series
 Heat Load(s): Radiant Floor Heating – Single Zone
 Date: 2014-09-02

Schematic #: SCH-TWH-M006
 Rough-in wiring see: SCH-MRIB-R001
 Wiring detail see: SCH-TWH-E006

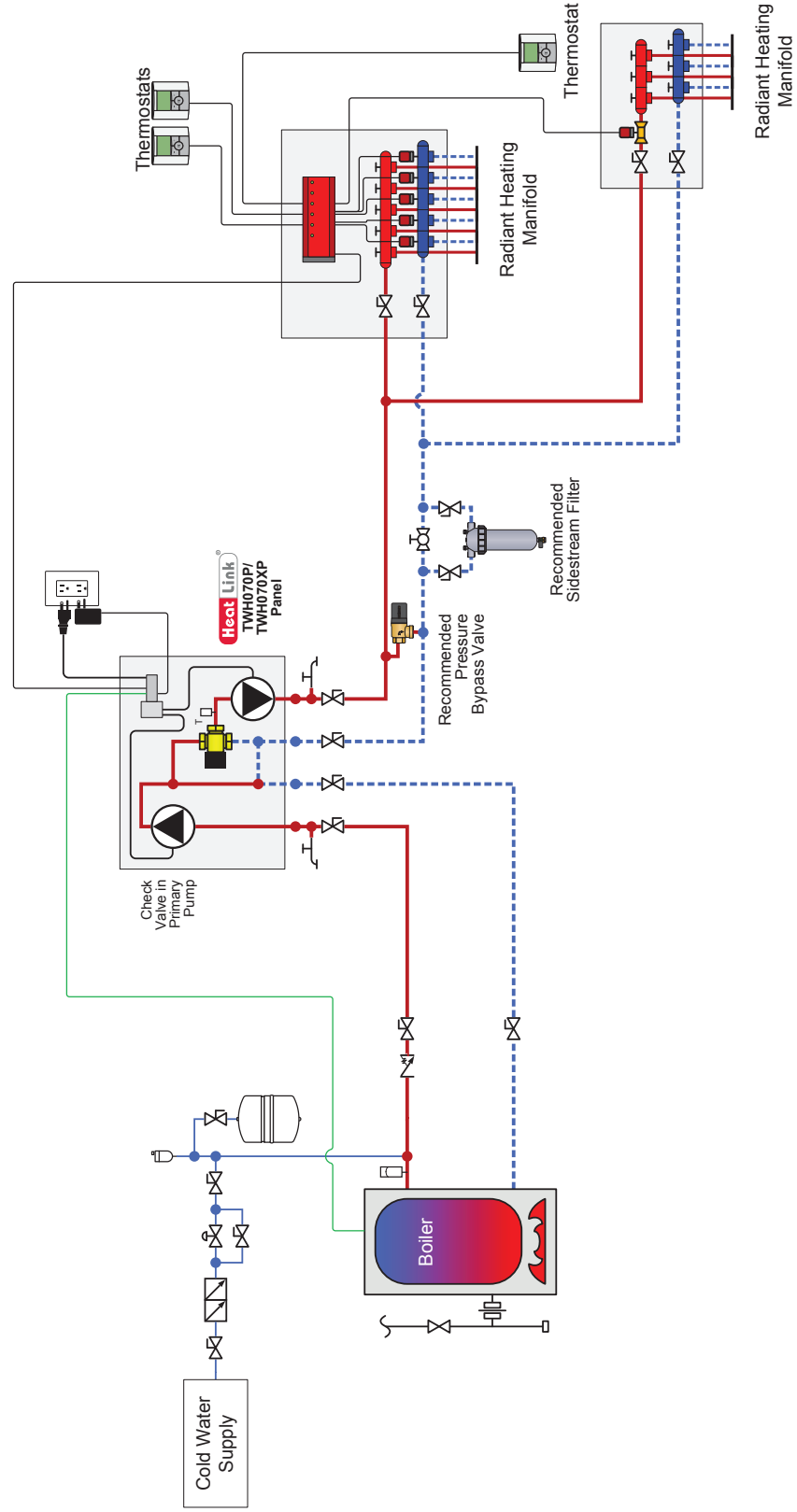

Notes:

- Drawings are for HeatLink suggested system layout only! User must determine if system layout will work for their particular application.
- Air vents, expansion tanks, pressure relief valves, etc. for heat source as per local codes.
- Use isolation ball valves for all circuits and components.
- Local codes, regulations, and authorities have final jurisdiction.

Heat Source: Boiler
 Panel(s): TWH Series
 Heat Load(s): Radiant Floor Heating – Multiple Zones
 Date: 2014-09-02

Schematic #: SCH-TWH-M007
 Rough-in wiring see: SCH-MRIB-R002
 Wiring detail see: SCH-TWH-E002

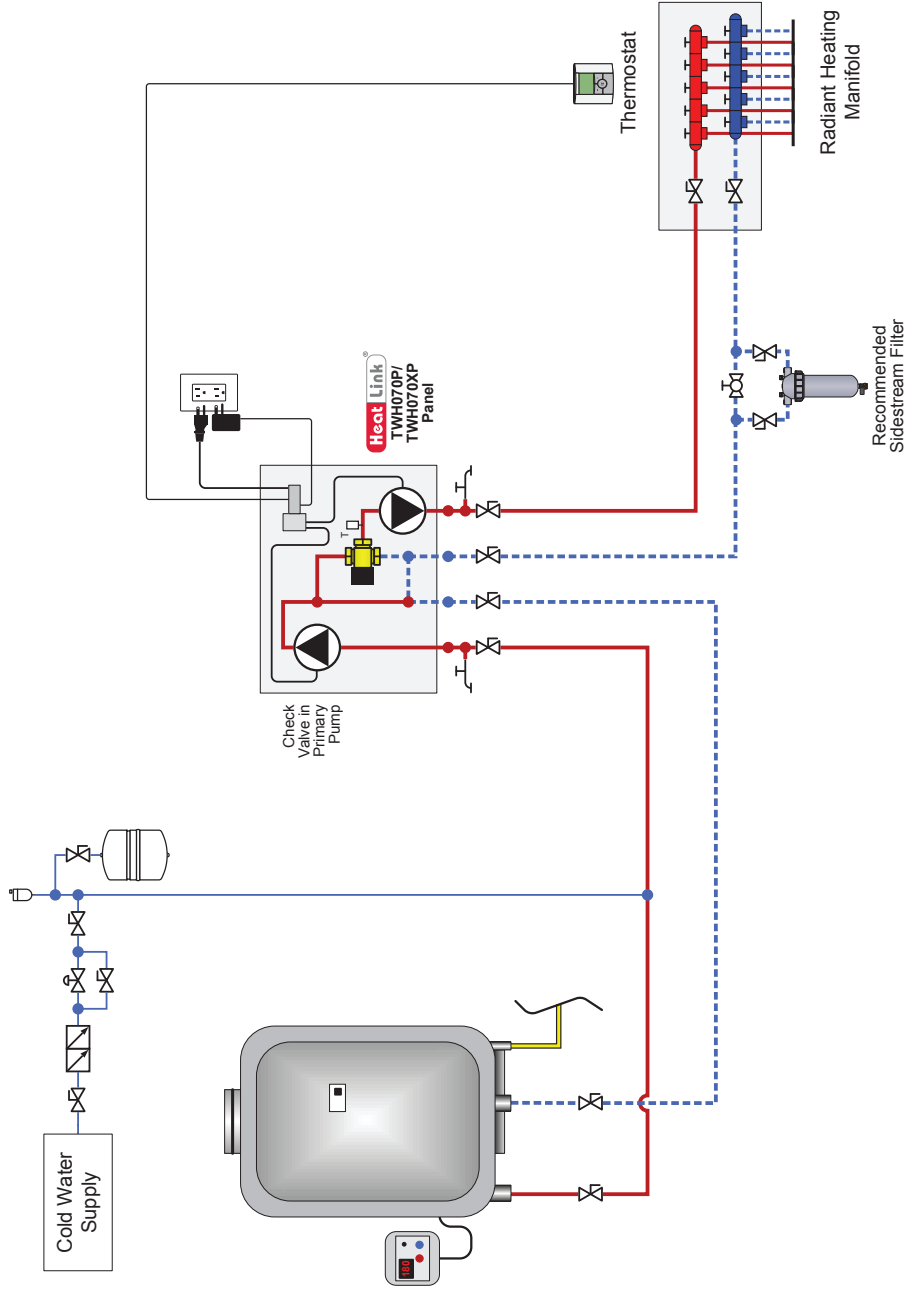

- Notes:**
- Drawings are for HeatLink suggested system layout only! User must determine if system layout will work for their particular application.
 - Air vents, expansion tanks, pressure relief valves, etc. for heat source as per local codes.
 - Use isolation ball valves for all circuits and components.
 - Local codes, regulations, and authorities have final jurisdiction.

Heat Link
 www.heatlink.com
 1-866-661-5332

Heat Source: Tankless Water Heater
 Panel(s): TWH Series
 Heat Load(s): Radiant Floor Heating – Single Zone
 Date: 2014-09-02

Schematic #: SCH-TWH-M008
 Rough-in wiring see: SCH-MRIB-R001
 Wiring detail see: SCH-TWH-E001

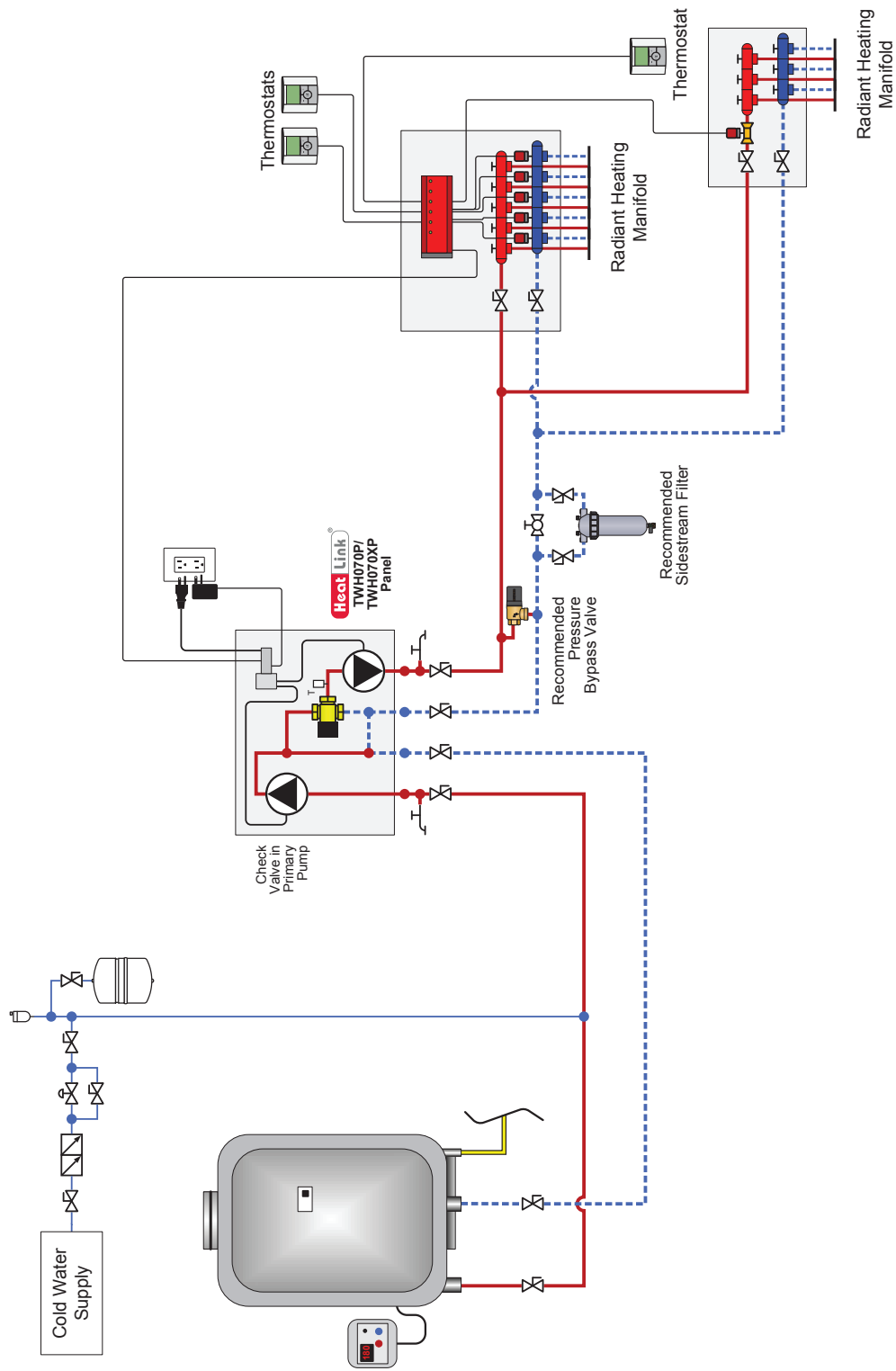

- Notes:**
- Drawings are for HeatLink suggested system layout only! User must determine if system layout will work for their particular application.
 - Air vents, expansion tanks, pressure relief valves, etc. for heat source as per local codes.
 - Use isolation ball valves for all circuits and components.
 - Local codes, regulations, and authorities have final jurisdiction.

Heat Link
 www.heatlink.com
 1-866-661-5332

Heat Source: Tankless Water Heater
 Panel(s): TWH Series
 Heat Load(s): Radiant Floor Heating – Single Zone

Date: 2014-09-02

Schematic #: SCH-TWH-M009

Rough-in wiring see: SCH-MRIB-R002

Wiring detail see: SCH-TWH-E007

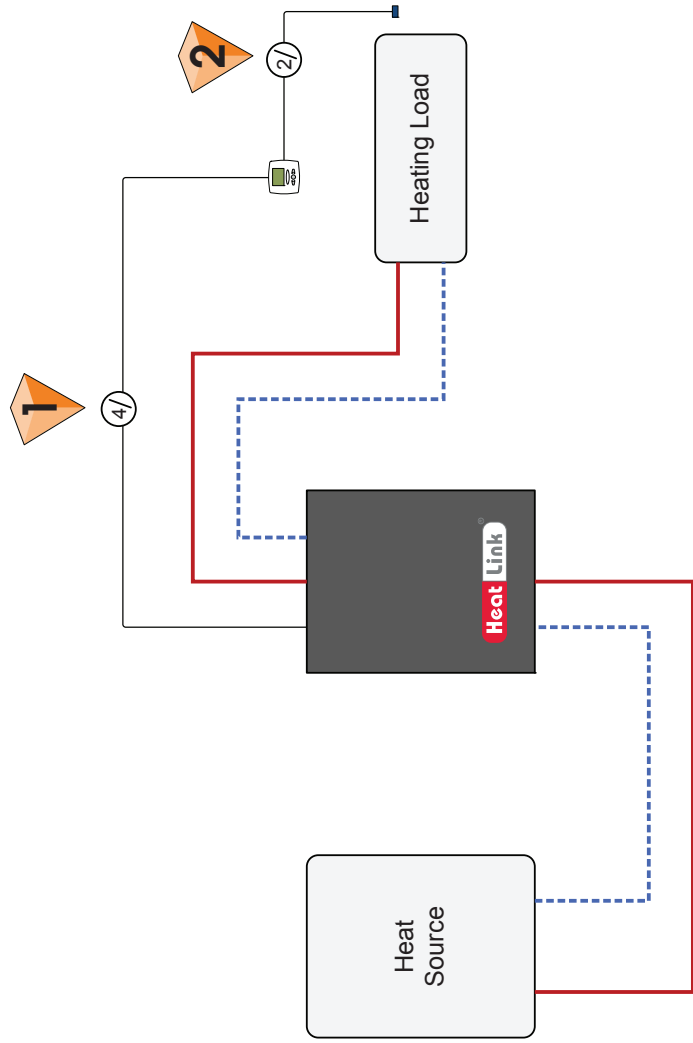

Room Thermostat

Standard 4-wire to be run from thermostat to mechanical room.



Floor Sensor (optional)

Standard 2-wire to be run from thermostat to floor sensor.

Heat Link[®]
 www.heatlinkgroup.com
 1-866-661-5332

Notes:

- Drawings are for HeatLink suggested electrical schematics only! User must determine if electrical schematic will work for their particular application. User must also confirm all HeatLink schematics with manufacturer schematics of each particular control chosen.
- In all cases manufacturer equipment schematics will take precedence over HeatLink electrical schematics.
- Local codes, regulations, and authorities have final jurisdiction.

Application: Rough-in Wiring for One Zone Heating

Schematic #: SCH-MRIB-R001

Date: 2012-10-19

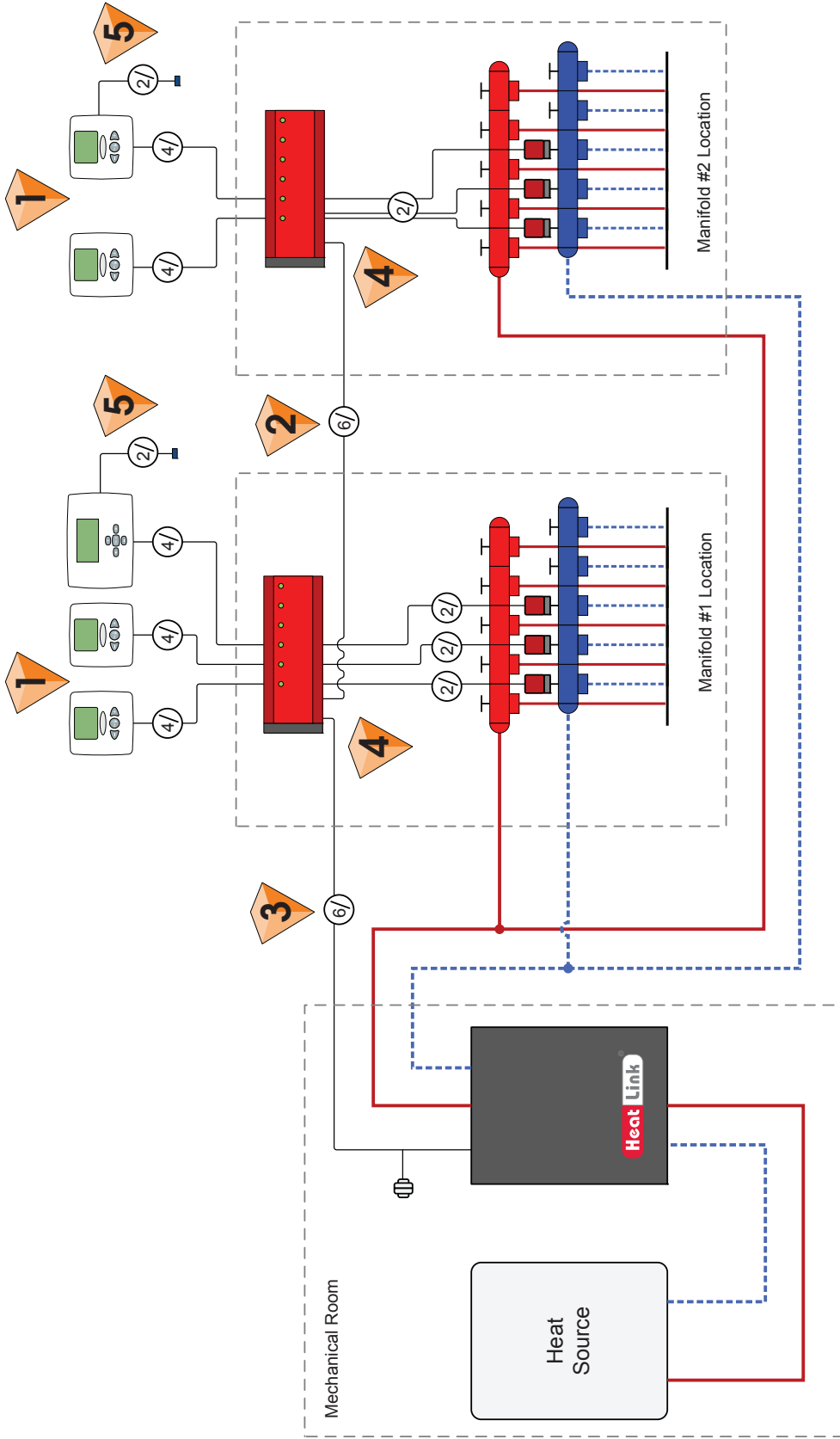

Room Thermostats

Standard 4-wire to be run from each zone back to the corresponding manifold location.



6-wire Jumper

6-wire to be run between each manifold location. This allows for the transfer of the clock signal, heat demand information, and power from module to module.



6-wire Jumper

6-wire to be run from the last manifold location to the mechanical room. This allows for the transfer of the clock signal, heat demand information, and power.



Optional

Allow for 110V power source to a 24V transformer at each manifold location instead of supplying 24V power from the mechanical room.



Floor Sensor (optional)

Standard 2-wire to be run from thermostat to floor sensor.



www.heatlinkgroup.com
1-866-661-5332

Notes:

- Drawings are for HeatLink suggested electrical schematics only! User must determine if electrical schematic will work for their particular application. User must also confirm all HeatLink schematics with manufacturer schematics of each particular control chosen.
- In all cases manufacturer equipment schematics will take precedence over HeatLink electrical schematics.
- Local codes, regulations, and authorities have final jurisdiction.

Application: Rough-in Wiring for Multiple Zone Heating with StatLink

Schematic #: SCH-MRIB-R002

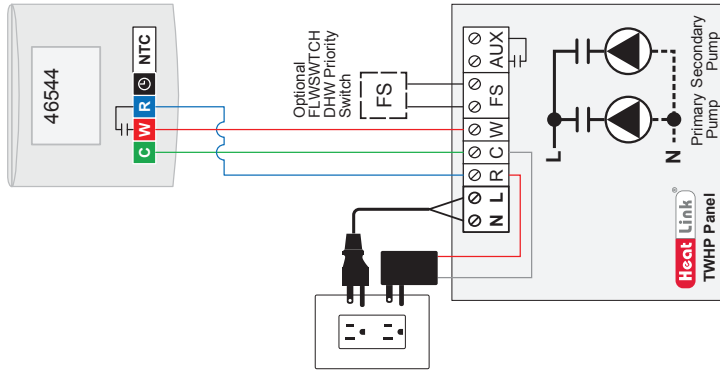

Notes:

- Drawings are for HeatLink suggested electrical schematics only! User must determine if electrical schematic will work for their particular application. User must also confirm all HeatLink schematics with manufacturer schematics of each particular control chosen.
- In all cases manufacturer equipment schematics will take precedence over HeatLink electrical schematics.
- Local codes, regulations, and authorities have final jurisdiction.

Application: Single Zone Heating

Schematic #: SCH-TWH-E001

Rough-in wiring see: SCH-MRIB-R001

Date: 2014-09-02

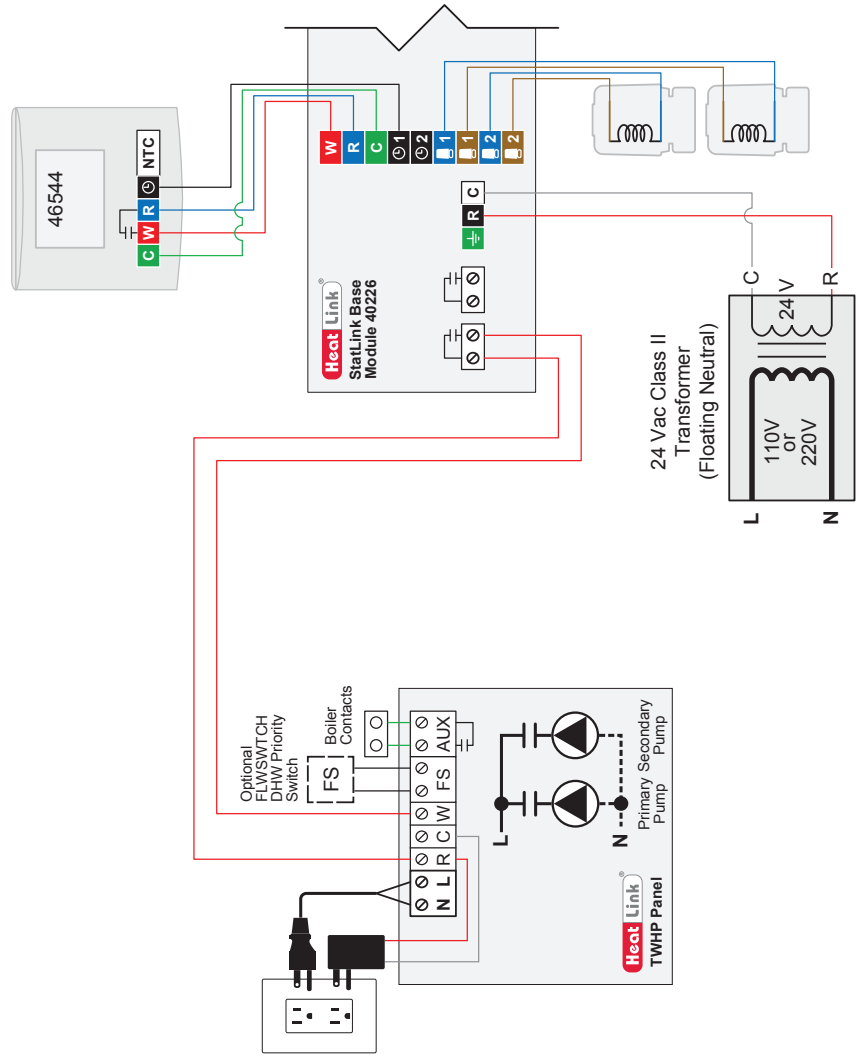

Notes:

- Drawings are for HeatLink suggested electrical schematics only! User must determine if electrical schematic will work for their particular application. User must also confirm all HeatLink schematics with manufacturer schematics of each particular control chosen.
- HeatLink manufacturer equipment schematics will take precedence over HeatLink electrical schematics.
- Local codes, regulations, and authorities have final jurisdiction.

Application: Multiple Zone Heating with StatLink

Schematic #: SCH-TWH-E002

Rough-in wiring see: SCH-MRIB-R002

Date: 2014-09-02

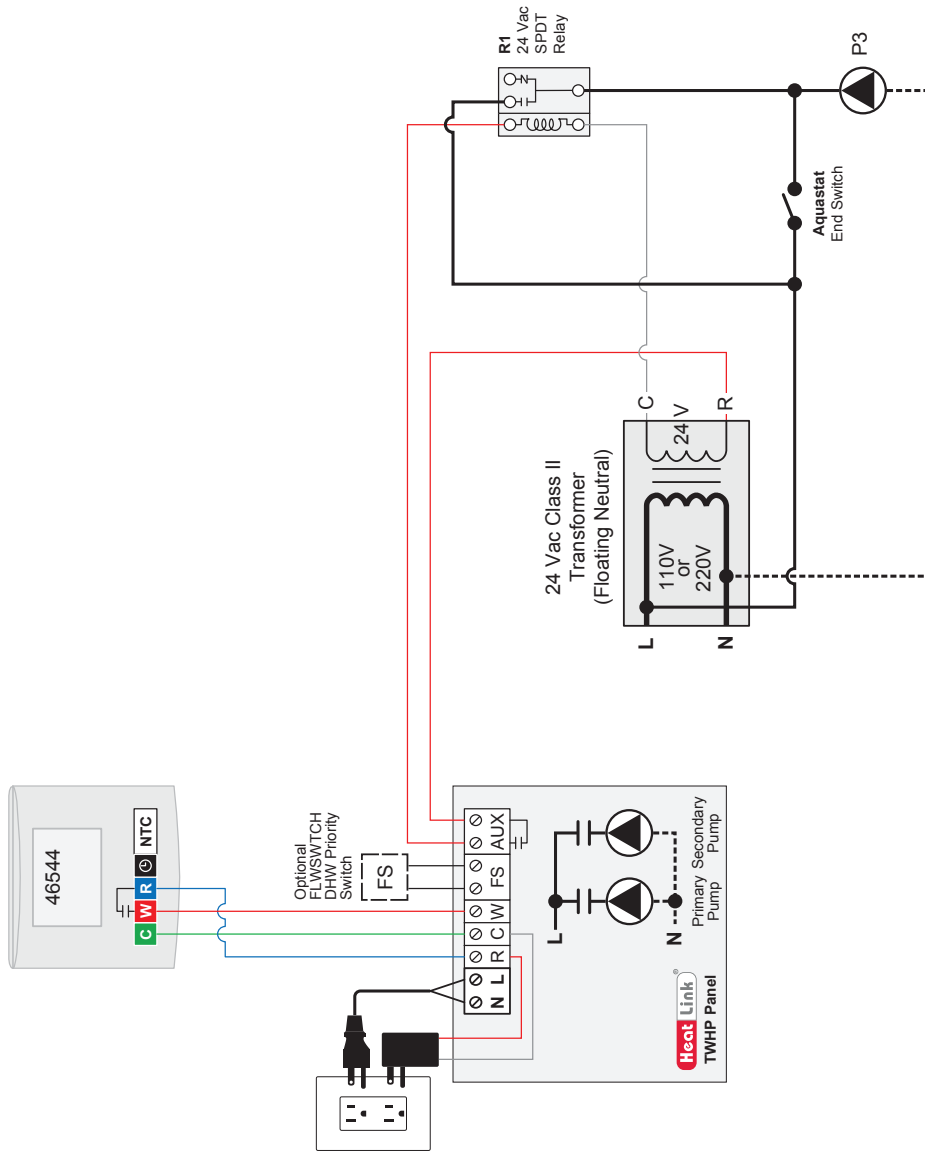

- Notes:**
- Drawings are for HeatLink suggested electrical schematics only! User must determine if electrical schematic will work for their particular application. User must also confirm all HeatLink schematics with manufacturer schematics of each particular control chosen.
 - In all cases manufacturer equipment schematics will take precedence over HeatLink electrical schematics.
 - Local codes, regulations, and authorities have final jurisdiction.

Application: One Zone Heating with Storage Tank

Schematic #: SCH-TWH-E003

Rough-in wiring see: SCH-MRIB-R001

Date: 2014-09-02

Heat Link
 www.heatlink.com
 1-866-661-5332

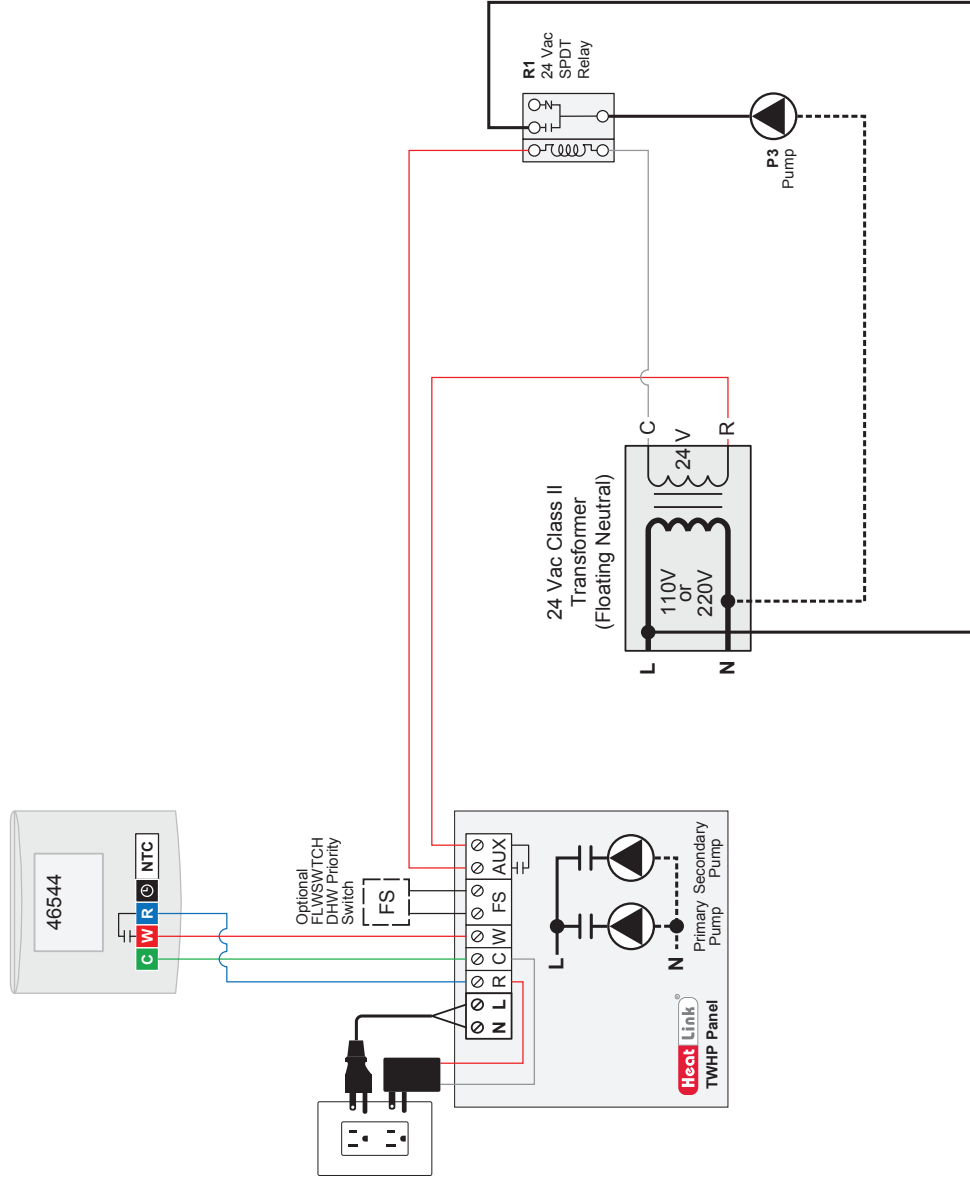

Notes:

- Drawings are for HeatLink suggested electrical schematics only! User must determine if electrical schematic will work for their particular application. User must also confirm all HeatLink schematics with manufacturer schematics of each particular control chosen.
- HeatLink manufacturer equipment schematics will take precedence over HeatLink electrical schematics.
- Local codes, regulations, and authorities have final jurisdiction.

Heat Link
 www.heatlink.com
 1-866-661-5332

Application: One Zone Heating with Fixed Speed Pump

Schematic #: SCH-TWH-E004

Rough-in wiring see: SCH-MRIB-R001

Date: 2014-09-02

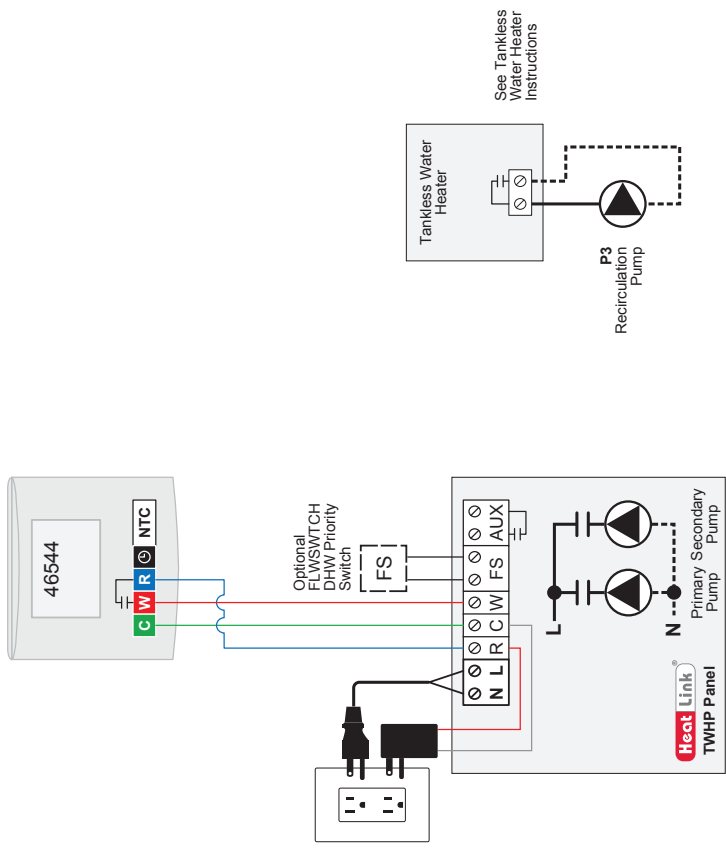

Notes:

- Drawings are for HeatLink suggested electrical schematics only! User must determine if electrical schematic will work for their particular application. User must also confirm all HeatLink schematics with manufacturer schematics of each particular control chosen.
- In all cases manufacturer equipment schematics will take precedence over HeatLink electrical schematics.
- Local codes, regulations, and authorities have final jurisdiction.

Heat Link
 www.heatlink.com
 1-866-661-5332

Application: Single Zone Heating

Schematic #: SCH-TWH-E005

Rough-in wiring see: SCH-MRIB-R001

Date: 2014-09-02

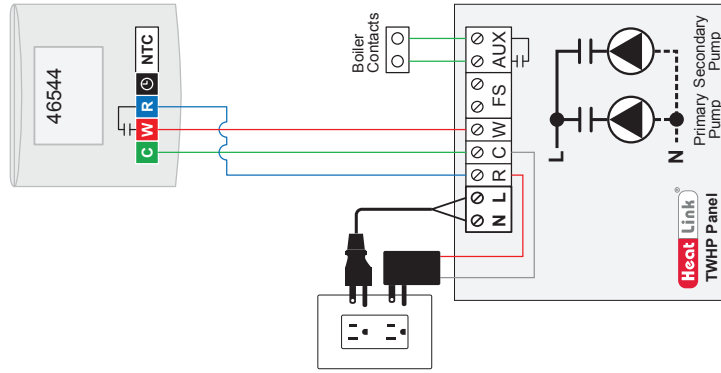

Notes:

- Drawings are for HeatLink suggested electrical schematics only! User must determine if electrical schematic will work for their particular application. User must also confirm all HeatLink schematics with manufacturer schematics of each particular control chosen.
- HeatLink manufacturer equipment schematics will take precedence over HeatLink electrical schematics.
- Local codes, regulations, and authorities have final jurisdiction.

Application: Single Zone Heating

Schematic #: SCH-TWH-E006

Rough-in wiring see: SCH-MRIB-R001

Date: 2014-09-02

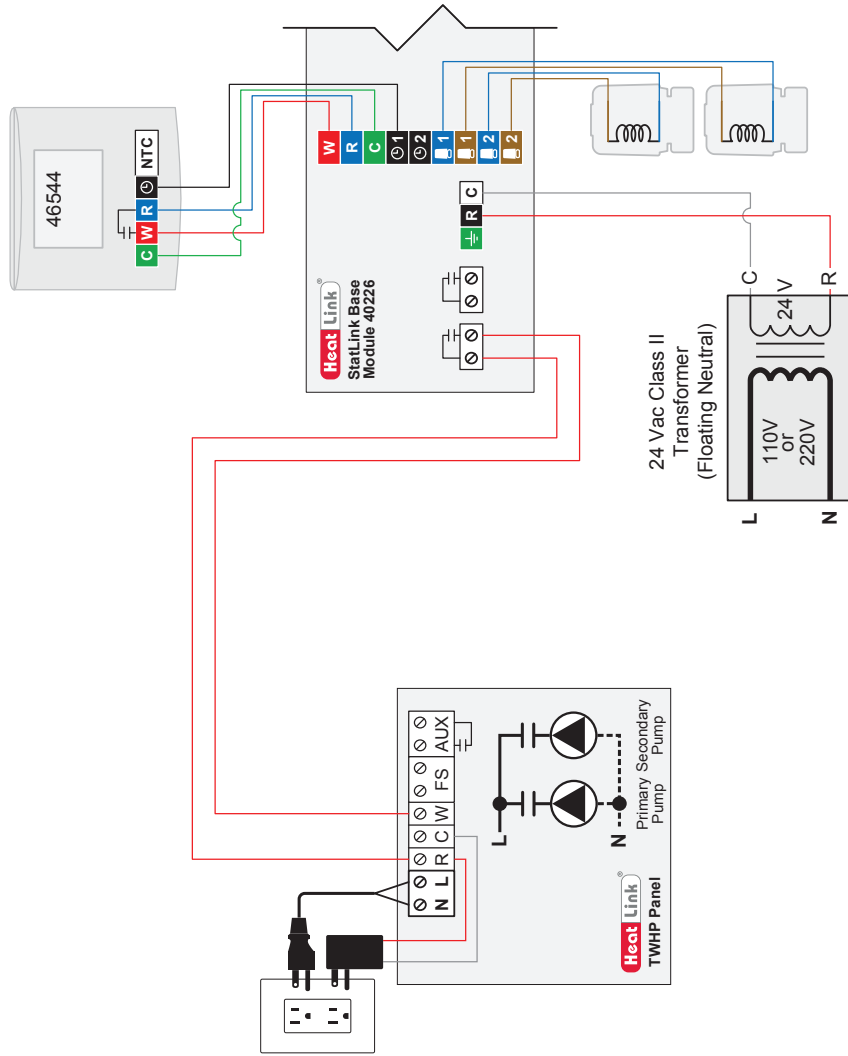

Notes:

- Drawings are for HeatLink suggested electrical schematics only! User must determine if electrical schematic will work for their particular application. User must also confirm all HeatLink schematics with manufacturer schematics of each particular control chosen.
- In all cases manufacturer equipment schematics will take precedence over HeatLink electrical schematics.
- Local codes, regulations, and authorities have final jurisdiction.

Heat Link
 www.heatlink.com
 1-866-661-5332

Application: Multiple Zone Heating with StatLink

Date: 2014-09-02

Schematic #: SCH-TWH-E007

Rough-in wiring see: SCH-MRIB-R002



Heat Link® Canada

Manufactured & distributed by HeatLink Group Inc.

Head Office:

4603E - 13th Street N.E.
Calgary, Alberta, T2E 6M3

Toll Free: 1-800-661-5332

International Phone: +1 (403) 250-3432

Fax: 1-866-450-1155

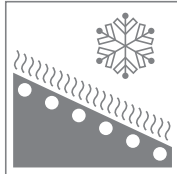

Heat Link® China

Distributed by Cathay-Links International

Phone: 852-25693213

Fax: 852-25359271

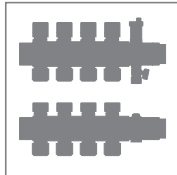

Heat Link® Ireland

Distributed by Jamoni Ltd.

Phone: 057 - 932 4062

Fax: 057 - 932 4063

Freephone: 1800-311338

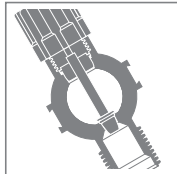

Heat Link® México

Distributed by Distribuidora Caisa S.A. de C.V.

Phone: (52-55) 3300-4400

Fax: (52-55) 3300-4406

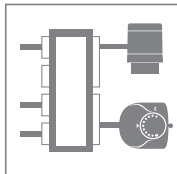

Heat Link® United States

Distributed by HeatLink Group Inc.

USA Distribution Center:

1000 - 100th Street SW, Suite B
Byron Center, MI, 49315

Toll Free: 1-800-661-5332

Fax: 1-800-869-6098



info@heatlink.com
www.heatlink.com

HeatLink, the HeatLink logo, and "Mechanical Room in a Box" logo are either registered trademarks or trademarks of HeatLink Group Inc.