

# LBS4607-1 Single, with ledge, 20 gauge

MODEL RANGE: COMMERCIAL SINKS | LBS4607-1

Commercial sinks | Topmount sinks

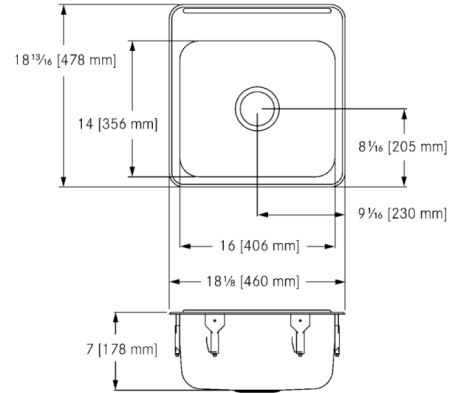

Single compartment self rimming topmount sink with faucet ledge. 20 gauge (0.9 mm), type 302 (CNS 18/8) stainless steel. Exposed surfaces are #4 satin finished. Undercoated to reduce condensation and resonance. Includes waste fitting, factory applied rim seal, cutout template, and factory installed EZ TORQUE™ fasteners. Certified to ASME A112.19.3-2008 / CSA B45.4-08.

Centre waste location. Includes 3 1/2" (89 mm) crumb cup strainer with 1 1/2" (DN38) brass tailpiece.

Model Options:

LBS4607-1/1, 1 faucet hole, 1 1/2" diameter

LBS4607-1/3, 3 faucet holes, 1 1/2" diameter, 4" centres, 8" centreset

LBS4607-1, Custom (non-returnable)

18 13/16 x 18 1/8" Overall. 14 x 16 x 7" Bowl. (FB x LR x D).

478 x 460 mm Overall. 356 x 406 x 178 mm Bowl. (FB x LR x D).

## Technical data

Bowl height	7 inch
Bowl depth	14 "
Bowl width	16 "
Overall depth	18 13/16 "
Overall width	18 1/8 "
Material	Stainless steel
Material code	1.4301 Chrome Nickel steel V2A
Tailor made	No
Tap ledge	Yes
Waste hole position	Center
Bowl finish	Satin finish
Number of bowls	1.00000
Overflow	No
Number of tap holes	0.00000
Type of waste kit	3 1/2" crump cup strainer
Type of basin	Single compartment

## PROJECT INFORMATION

Item Location	
Project Number	
Quote Number	
Notes	

## ENGINEER'S APPROVAL