

COOLING CAPACITY : 23,400 - 57,500 BTU/H

**HIGH-EFFICIENCY
PACKAGED AIR CONDITIONER
2 TO 5 TONS
15 SEER**

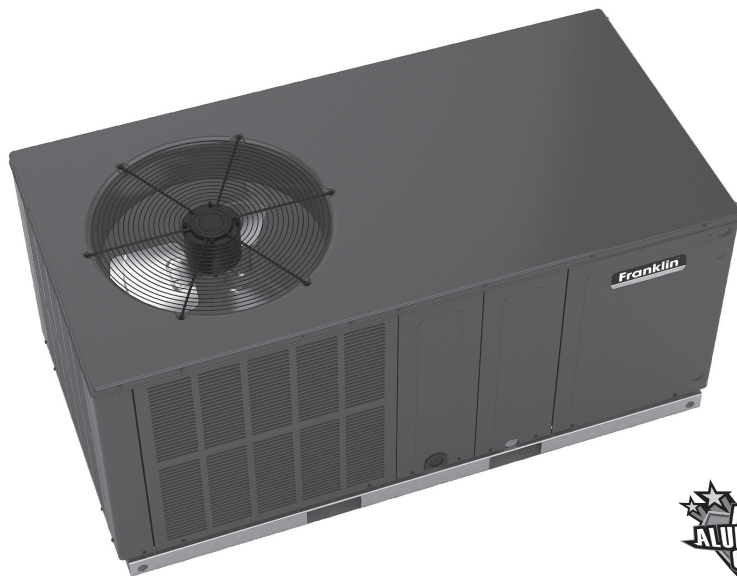

Contents

Nomenclature..... 2
 Accessories 2
 Product Specifications..... 3
 Expanded Cooling Data 4
 Airflow Data 16
 Heater Kit Specifications 17
 Wiring Diagrams 18
 Dimensions 20

Standard Features

- Energy-efficient compressor with internal relief valve
- Multi-speed ECM indoor blower motor
- Quiet horizontal discharge
- Copper tube/aluminum fin condenser coil
- All-aluminum evaporator coil
- Totally enclosed, permanently lubricated condenser fan motor
- Fully charged system
- 5 kW to 20 kW electric heat kit available as a field-installed option
- AHRI Certified; ETL listed

Cabinet Features

- Heavy-gauge galvanized-steel cabinet with attractive Architectural Gray powder-paint finish
- Louvered condenser coil protection
- Aluminum foil-facing internal insulation reinforced with fiberglass scrim
- Fully insulated blower compartment with convenient access panels
- Meets cabinet air leakage requirements when tested in accordance with ASHRAE standard 193
- One footprint for all tonnages





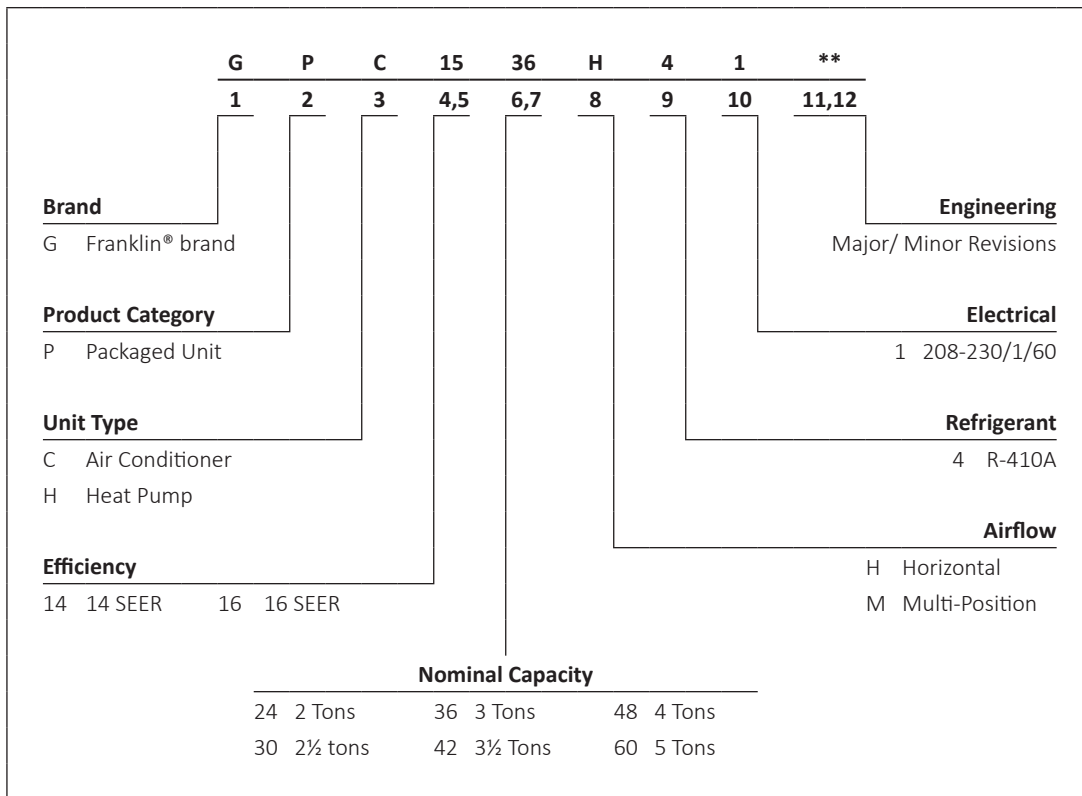

* Complete warranty details available from your local dealer or at www.franklinhvacsystems.com. To receive the 10-Year Parts Limited Warranty, online registration must be completed within 60 days of installation. Online registration is not required in California or Quebec.



ACCESSORIES

ACCESSORY DESCRIPTION	ITEM NUMBER	
	SMALL CHASSIS	MEDIUM/LARGE CHASSIS
Downflow Economizer (use w/PCCP roof curb)	DDNECNJPCHHA	DDNECNJPCHHA
Downflow Plenum Kit (use w/PCCP roof curb)	PCP101-103	PCP101-103
Downflow Plenum Kit (R-8) (use w/PCCP roof curb)	PCP101-103 R8	PCP101-103 R8
Elbow Flashing w/R-8 Liner	PCEF101-103	PCEF101-103
Economizer Wiring Harness (2-4 Ton)	0259G00213	0259G00213
Economizer Wiring Harness (5 Ton)	N/A	0259L00412
External Horizontal Filter Rack	DPHFRA	DPHFRA
Horizontal Economizer	DHZECNJPCHM	DHZECNJPCHM
Manual Damper	PCMD101-103	PCMD101-103
Manual Damper - Horizontal	GPHMD101-103	GPHMD101-103
Motorized Damper	PCMDM101-103	PCMDM101-103
Outdoor Thermostat & Emergency Heat Relay Kit	OT/EHR18-60	OT/EHR18-60
Outdoor Thermostat Kit w/ Lockout Stat	OT18-60A	OT18-60A
Roof Curb	PCCP101-103	PCCP101-103
Square to Round Downflow (use w/PCCP roof curb)	SQRPC101	SQRPC102-103
Square to Round Horizontal	SQRPCH101	SQRPCH102-103

MODELS	GPC15 24H41A*	GPC15 30H41A*	GPC15 36H41B*	GPC15 42H41A*	GPC15 48H41A*	GPC15 60H41B*
COOLING CAPACITY						
Cooling Capacity (BTU/h)	23,600	28,400	35,200	40,000	46,000	57,000
Sensible BTU/h	17,700	21,600	27,200	30,400	35,300	39,000
SEER / EER	15.0 / 12.0	15.0 / 12.0	15.0 / 12.0	15.0 / 12.0	15.0 / 12.0	15.0 / 12.0
Decibels	76	76	78	78	80	80
AHRI Numbers	8004954	8004955	8004956	8004957	8004958	8005102
EVAPORATOR MOTOR						
Type	ECM	ECM	ECM	ECM	ECM	ECM
Wheel (D x W)	10 x 8	10 x 8	10 x 8	10 x 8	10 x 8	11 x 8
Cooling CFM	875	1,050	1,200	1,300	1,600	1,600
Fan-Only CFM	800	950	1,100	1,200	1,400	1,700
RLA	1.5	1.86	1.86	2.9	2.9	2.9
No. of Speeds	5	5	5	5	5	5
Horsepower - RPM	½ - 1050	½ - 1050	½ - 1050	½ - 1050	¾ - 1050	¾ - 1050
EVAPORATOR COIL						
Face Area (ft ²)	5.25	5.25	5.25	5.25	6.2	6.2
Rows Deep/ Fins per Inch	3/ 14	3/ 14	4/ 14	4/ 14	4/ 14	4/ 14
Indoor Orifice Size	0.06	0.06	0.068	0.08	0.08	TXV
Filter Size (")	20 x 20 x 1	20 x 25 x 1	25 x 25 x 1	(2) 20 x 20 x 1	(2) 20 x 20 x 1	(2) 20 x 25 x 1
All-Aluminum coil	X	X	X	X	X	X
Drain Size (NPT)	¾"	¾"	¾"	¾"	¾"	¾"
Refrigerant Charge (oz.)	54	55	67	102	115	103
CONDENSER FAN / COIL						
Horsepower - RPM	1/6 - 815	1/6 - 815	¼ - 830	¼ - 1075	¼ - 1075	¼ - 1075
RLA/LRA	1.1 / 1.7	1.1 / 1.7	1.5 / 3.0	1.4 / 2.9	1.4 / 2.9	1.4 / 2.9
Fan Diameter/ # Fan Blades	22 / 2	22 / 2	22 / 3	22 / 4	22 / 4	22 / 4
Face Area (ft ²)	9.3	12.3	12.3	12.7	15.2	15.2
Rows Deep/ Fins per Inch	1 / 27	1 / 27	1 / 27	2 / 27	2 / 27	2 / 27
COMPRESSOR						
Quantity / Type	1 / Rotary	1 / Scroll	1 / Scroll	1 / Scroll	1 / Scroll	1 / Scroll
Stage	Single	Single	Single	Single	Single	Two
Compressor RLA/LRA	7.7/37	14.1/ 64	14.1 / 77	17.9 / 112	19.9 / 109	25.6 / 147
ELECTRICAL DATA						
Voltage-Phase (60 Hz)	208/230-1	208/230-1	208/230-1	208/230-1	208/230-1	208/230-1
Indoor Blower FLA	3.8	3.8	3.8	3.8	5.4	5.4
Outdoor Fan RLA	1.1	1.1	1.5	1.4	1.4	1.4
Total Unit Amps	12.6	19	19.4	23.1	26.7	32.4
Min. Circuit Ampacity ¹	15	23	23	28	32	39
Max. Overcurrent Protection (amps) ²	20	35	35	45	50	60
OPERATING WEIGHT (LBS)						
	300	305	315	350	365	370
SHIP WEIGHT (LBS)						
	309	314	324	359	377	382
ENERGY STAR® CERTIFIED						
			NO			NO

¹ Wire size should be determined in accordance with National Electrical Codes. Extensive wire runs will require larger wire sizes.

² Must use time-delay fuses or HACR-type circuit breakers of the same size as noted.

Note: Always check the S&R plate for electrical data on the unit being installed.

IDB	AIRFLOW	OUTDOOR AMBIENT TEMPERATURE																											
		65				75				85				95				105				115							
		59	63	67	71	59	63	67	71	59	63	67	71	59	63	67	71	59	63	67	71	59	63	67	71				
70	MBh	23.1	24.0	26.3	-	22.6	23.4	25.7	-	22.1	22.9	25.0	-	21.5	22.3	24.4	-	20.4	21.2	23.2	-	20.4	21.2	23.2	-	18.9	19.6	21.5	-
	S/T	0.79	0.66	0.46	-	0.82	0.68	0.47	-	0.84	0.70	0.49	-	0.87	0.72	0.50	-	0.90	0.75	0.52	-	0.90	0.75	0.52	-	0.91	0.76	0.52	-
	ΔT	17	15	11	-	17	15	11	-	17	15	11	-	17	15	11	-	17	15	11	-	17	15	11	-	16	14	11	-
	kW	1.42	1.45	1.50	-	1.53	1.57	1.62	-	1.63	1.67	1.73	-	1.72	1.76	1.82	-	1.80	1.84	1.91	-	1.80	1.84	1.91	-	1.87	1.91	1.98	-
	Amps	6.1	6.2	6.4	-	6.6	6.7	6.9	-	7.1	7.2	7.5	-	7.5	7.7	7.9	-	8.0	8.2	8.4	-	8.0	8.2	8.4	-	8.4	8.6	8.9	-
	HI PR	238	256	270	-	267	287	303	-	303	327	345	-	346	372	393	-	389	418	442	-	389	418	442	-	430	462	488	-
LO PR	108	115	125	-	114	121	132	-	118	126	137	-	124	132	144	-	130	138	151	-	130	138	151	-	135	143	156	-	
70	MBh	22.5	23.3	25.5	-	21.9	22.7	24.9	-	21.4	22.2	24.3	-	20.9	21.6	23.7	-	19.8	20.6	22.5	-	19.8	20.6	22.5	-	18.4	19.1	20.9	-
	S/T	0.75	0.63	0.44	-	0.78	0.65	0.45	-	0.80	0.67	0.46	-	0.83	0.69	0.48	-	0.86	0.72	0.50	-	0.86	0.72	0.50	-	0.86	0.72	0.50	-
	ΔT	18	15	12	-	18	16	12	-	18	16	12	-	18	16	12	-	18	15	12	-	18	15	12	-	17	14	11	-
	kW	1.40	1.44	1.48	-	1.52	1.55	1.61	-	1.62	1.66	1.71	-	1.71	1.75	1.81	-	1.78	1.83	1.89	-	1.78	1.83	1.89	-	1.85	1.89	1.96	-
	Amps	6.1	6.2	6.4	-	6.5	6.6	6.8	-	7.0	7.2	7.4	-	7.5	7.6	7.9	-	7.9	8.1	8.3	-	7.9	8.1	8.3	-	8.3	8.5	8.8	-
	HI PR	235	253	268	-	264	284	300	-	300	323	341	-	342	368	389	-	385	414	438	-	385	414	438	-	425	458	483	-
LO PR	107	113	124	-	113	120	131	-	117	125	136	-	123	131	143	-	129	137	150	-	129	137	150	-	133	142	155	-	
770	MBh	21.3	22.1	24.2	-	20.8	21.6	23.7	-	20.3	21.1	23.1	-	19.8	20.6	22.5	-	18.8	19.5	21.4	-	18.8	19.5	21.4	-	17.5	18.1	19.8	-
	S/T	0.72	0.60	0.42	-	0.75	0.62	0.43	-	0.77	0.64	0.44	-	0.79	0.66	0.46	-	0.82	0.69	0.48	-	0.82	0.69	0.48	-	0.83	0.69	0.48	-
	ΔT	18	16	12	-	19	16	12	-	19	16	12	-	19	16	12	-	18	16	12	-	18	16	12	-	17	15	11	-
	kW	1.38	1.41	1.46	-	1.49	1.53	1.58	-	1.59	1.63	1.68	-	1.68	1.72	1.78	-	1.75	1.79	1.86	-	1.75	1.79	1.86	-	1.82	1.86	1.92	-
	Amps	6.0	6.1	6.3	-	6.4	6.5	6.7	-	6.9	7.1	7.3	-	7.3	7.5	7.7	-	7.8	7.9	8.2	-	7.8	7.9	8.2	-	8.2	8.4	8.7	-
	HI PR	231	248	262	-	259	279	294	-	294	317	335	-	335	361	381	-	377	406	429	-	377	406	429	-	417	449	474	-
LO PR	104	111	121	-	110	117	128	-	115	122	133	-	121	128	140	-	126	134	147	-	126	134	147	-	131	139	152	-	

IDB	AIRFLOW	OUTDOOR AMBIENT TEMPERATURE																											
		65				75				85				95				105				115							
		59	63	67	71	59	63	67	71	59	63	67	71	59	63	67	71	59	63	67	71	59	63	67	71				
75	MBh	23.5	24.2	26.2	28.1	23.0	23.7	25.6	27.5	22.4	23.1	25.0	26.8	21.9	22.5	24.4	26.2	20.8	21.4	23.2	24.9	20.8	21.4	23.2	24.9	19.3	19.8	21.5	23.0
	S/T	0.90	0.80	0.61	0.39	0.93	0.83	0.63	0.41	0.95	0.85	0.65	0.42	0.98	0.88	0.67	0.43	1.00	0.91	0.69	0.45	1.00	0.91	0.69	0.45	1.00	0.92	0.70	0.45
	ΔT	20	18	15	10	20	18	15	10	20	18	15	10	20	19	15	11	19	18	15	10	19	18	15	10	18	17	14	10
	kW	1.43	1.46	1.51	1.56	1.54	1.58	1.63	1.69	1.65	1.69	1.74	1.80	1.74	1.78	1.84	1.90	1.82	1.86	1.92	1.99	1.82	1.86	1.92	1.99	1.88	1.93	1.99	2.06
	Amps	6.2	6.3	6.5	6.7	6.6	6.8	7.0	7.2	7.1	7.3	7.5	7.8	7.6	7.8	8.0	8.3	8.0	8.2	8.5	8.8	8.0	8.2	8.5	8.8	8.5	8.7	9.0	9.3
	HI PR	240	259	273	285	270	290	306	320	307	330	348	363	349	376	397	414	393	423	446	466	393	423	446	466	434	467	493	514
LO PR	109	116	126	135	115	122	133	142	119	127	139	148	125	133	146	155	132	140	153	163	132	140	153	163	136	145	158	168	
770	MBh	22.8	23.5	25.4	27.3	22.3	23.0	24.9	26.7	21.8	22.4	24.3	26.0	21.2	21.9	23.7	25.4	20.2	20.8	22.5	24.1	20.2	20.8	22.5	24.1	18.7	19.2	20.8	22.4
	S/T	0.86	0.77	0.58	0.37	0.89	0.79	0.60	0.39	0.91	0.81	0.62	0.40	0.94	0.84	0.64	0.41	0.97	0.87	0.66	0.42	0.97	0.87	0.66	0.42	0.98	0.88	0.67	0.43
	ΔT	21	19	15	11	21	19	16	11	21	19	16	11	21	19	16	11	21	19	16	11	21	19	16	11	19	18	15	10
	kW	1.42	1.45	1.50	1.55	1.53	1.57	1.62	1.68	1.63	1.67	1.73	1.79	1.72	1.76	1.82	1.89	1.80	1.84	1.91	1.97	1.80	1.84	1.91	1.97	1.87	1.91	1.98	2.05
	Amps	6.1	6.2	6.4	6.6	6.6	6.7	6.9	7.1	7.1	7.2	7.5	7.7	7.5	7.7	7.9	8.2	8.0	8.2	8.4	8.7	8.0	8.2	8.4	8.7	8.4	8.6	8.9	9.2
	HI PR	238	256	270	282	267	287	303	316	304	327	345	360	346	372	393	410	389	419	442	461	389	419	442	461	430	462	488	509
LO PR	108	115	125	133	114	121	132	141	118	126	137	146	124	132	144	154	130	139	151	161	130	139	151	161	135	143	156	167	
770	MBh	21.7	22.3	24.2	25.9	21.2	21.8	23.6	25.3	20.7	21.3	23.0	24.7	20.2	20.8	22.5	24.1	19.2	19.7	21.4	22.9	19.2	19.7	21.4	22.9	17.8	18.3	19.8	21.2
	S/T	0.82	0.73	0.56	0.36	0.85	0.76	0.58	0.37	0.87	0.78	0.59	0.38	0.90	0.80	0.61	0.39	0.93	0.84	0.63	0.41	0.93	0.84	0.63	0.41	0.94	0.84	0.64	0.41
	ΔT	21	20	16	11	22	20	16	11	22	20	16	11	22	20	16	11	21	20	16	11	21	20	16	11	20	18	15	10
	kW	1.39	1.42	1.47	1.52	1.51	1.54	1.59	1.65	1.61	1.64	1.70	1.76	1.69	1.73	1.79	1.86	1.77	1.81	1.87	1.94	1.77	1.81	1.87	1.94	1.83	1.88	1.94	2.01
	Amps	6.0	6.1	6.3	6.5	6.4	6.6	6.8	7.0	7.0	7.1	7.3	7.6	7.4	7.6	7.8	8.1	7.8	8.0	8.3	8.6	7.8	8.0	8.3	8.6	8.3	8.5	8.7	9.0
	HI PR	233	251	265	276	262	281	297	310	297	320	338	353	339	365	385	402	381	410	433	452	381	410	433	452	421	453	479	499
LO PR	106	112	123	131	112	119	130	138	116	123	135	143	122	130	141	151	128	136	148	158	128	136	148	158	132	140	153	163	

IDB = Entering Indoor Dry Bulb Temperature
 High and low pressures are measured at the liquid and suction access fittings.
 Design Subcooling, 8±3 °F @ the liquid access fitting connection AHRI 95 test conditions. Design Superheat 9±3 °F @ the compressor suction access fitting connection.
 Shaded area reflects ACCA (TVA) conditions.
 kW = total system power
 Amps: Unit amps (comp.+ evaporator + condenser fan motors)

IDB		OUTDOOR AMBIENT TEMPERATURE																							
		65				75				85				95				105				115			
		59	63	67	71	59	63	67	71	59	63	67	71	59	63	67	71	59	63	67	71	59	63	67	71
		ENTERING INDOOR WET BULB TEMPERATURE																							
		AIRFLOW																							
70	MBh	27.8	28.8	31.6	-	27.2	28.2	30.9	-	26.5	27.5	30.1	-	25.9	26.8	29.4	-	24.6	25.5	27.9	-	22.8	23.6	25.9	-
	S/T	0.74	0.62	0.43	-	0.77	0.64	0.44	-	0.79	0.66	0.45	-	0.81	0.68	0.47	-	0.84	0.70	0.49	-	0.85	0.71	0.49	-
	ΔT	16	14	11	-	16	14	11	-	16	14	11	-	16	14	11	-	16	14	11	-	15	13	10	-
	kW	1.81	1.86	1.92	-	1.96	2.01	2.08	-	2.09	2.14	2.22	-	2.21	2.26	2.34	-	2.31	2.36	2.45	-	2.39	2.45	2.54	-
	Amps	7.6	7.8	8.0	-	8.2	8.4	8.6	-	8.9	9.1	9.3	-	9.4	9.6	9.9	-	10.0	10.2	10.5	-	10.6	10.8	11.1	-
	HI PR	241	260	274	-	271	291	308	-	308	331	350	-	351	378	399	-	395	425	448	-	436	469	496	-
	LO PR	107	114	125	-	113	121	132	-	118	125	137	-	124	132	144	-	130	138	151	-	134	143	156	-
	MBh	27.0	28.0	30.7	-	26.4	27.4	30.0	-	25.8	26.7	29.3	-	25.1	26.1	28.5	-	23.9	24.7	27.1	-	22.1	22.9	25.1	-
	S/T	0.71	0.59	0.41	-	0.73	0.61	0.42	-	0.75	0.63	0.43	-	0.77	0.65	0.45	-	0.80	0.67	0.46	-	0.81	0.68	0.47	-
	ΔT	17	14	11	-	17	15	11	-	17	15	11	-	17	15	11	-	17	15	11	-	16	14	10	-
kW	1.80	1.84	1.90	-	1.95	1.99	2.06	-	2.08	2.12	2.20	-	2.19	2.24	2.32	-	2.29	2.34	2.42	-	2.37	2.43	2.51	-	
Amps	7.6	7.7	8.0	-	8.1	8.3	8.6	-	8.8	9.0	9.3	-	9.3	9.6	9.9	-	9.9	10.1	10.5	-	10.5	10.7	11.0	-	
HI PR	239	257	272	-	268	289	305	-	305	328	347	-	347	374	395	-	391	420	444	-	432	465	491	-	
LO PR	106	113	123	-	112	119	130	-	117	124	135	-	122	130	142	-	128	137	149	-	133	141	154	-	
MBh	24.9	25.8	28.3	-	24.4	25.2	27.7	-	23.8	24.6	27.0	-	23.2	24.0	26.3	-	22.0	22.8	25.0	-	20.4	21.2	23.2	-	
S/T	0.68	0.57	0.39	-	0.70	0.59	0.41	-	0.72	0.60	0.42	-	0.75	0.62	0.43	-	0.77	0.65	0.45	-	0.78	0.65	0.45	-	
ΔT	17	15	11	-	17	15	11	-	17	15	11	-	17	15	11	-	17	15	11	-	16	14	10	-	
kW	1.75	1.79	1.85	-	1.90	1.94	2.01	-	2.02	2.07	2.14	-	2.13	2.18	2.26	-	2.23	2.28	2.36	-	2.31	2.36	2.45	-	
Amps	7.4	7.5	7.8	-	7.9	8.1	8.3	-	8.6	8.7	9.0	-	9.1	9.3	9.6	-	9.6	9.9	10.2	-	10.2	10.4	10.8	-	
HI PR	232	249	263	-	260	280	296	-	296	318	336	-	337	363	383	-	379	408	431	-	419	451	476	-	
LO PR	103	110	120	-	109	116	126	-	113	120	131	-	119	126	138	-	125	132	145	-	129	137	150	-	

75	MBh	28.3	29.1	31.5	33.9	27.6	28.5	30.8	33.1	27.0	27.8	30.1	32.3	26.3	27.1	29.3	31.5	25.0	25.8	27.9	29.9	23.2	23.9	25.8	27.7
	S/T	0.84	0.75	0.57	0.37	0.87	0.78	0.59	0.38	0.89	0.80	0.60	0.39	0.92	0.82	0.62	0.40	0.96	0.86	0.65	0.42	0.96	0.86	0.65	0.42
	ΔT	19	17	14	10	19	17	14	10	19	17	14	10	19	17	14	10	19	17	14	10	17	16	13	9
	kW	1.83	1.87	1.93	2.00	1.98	2.03	2.09	2.17	2.11	2.16	2.24	2.31	2.23	2.28	2.36	2.44	2.33	2.38	2.47	2.56	2.42	2.47	2.56	2.65
	Amps	7.7	7.9	8.1	8.4	8.3	8.5	8.7	9.0	8.9	9.1	9.4	9.8	9.5	9.7	10.0	10.4	10.1	10.3	10.6	11.0	10.6	10.9	11.2	11.6
	HI PR	244	262	277	289	274	294	311	324	311	335	354	369	354	381	403	420	399	429	453	473	441	474	501	522
	LO PR	108	115	126	134	114	122	133	142	119	127	138	147	125	133	145	155	131	139	152	162	135	144	157	168
	MBh	27.5	28.3	30.6	32.9	26.8	27.6	29.9	32.1	26.2	27.0	29.2	31.3	25.6	26.3	28.5	30.6	24.3	25.0	27.1	29.0	22.5	23.2	25.1	26.9
	S/T	0.80	0.72	0.54	0.35	0.83	0.74	0.56	0.36	0.85	0.76	0.58	0.37	0.88	0.79	0.60	0.38	0.91	0.82	0.62	0.40	0.92	0.82	0.62	0.40
	ΔT	19	18	15	10	20	18	15	10	20	18	15	10	20	18	15	10	19	18	15	10	18	17	14	9
kW	1.81	1.86	1.92	1.98	1.96	2.01	2.08	2.15	2.09	2.14	2.22	2.29	2.21	2.26	2.34	2.42	2.31	2.36	2.45	2.53	2.39	2.45	2.54	2.63	
Amps	7.6	7.8	8.0	8.3	8.2	8.4	8.6	8.9	8.9	9.1	9.3	9.7	9.4	9.6	9.9	10.3	10.0	10.2	10.5	10.9	10.6	10.8	11.1	11.5	
HI PR	241	260	274	286	271	291	308	321	308	332	350	365	351	378	399	416	395	425	449	468	436	469	496	517	
LO PR	107	114	125	133	113	121	132	140	118	125	137	146	124	132	144	153	130	138	151	160	134	143	156	166	
MBh	25.4	26.1	28.3	30.3	24.8	25.5	27.6	29.6	24.2	24.9	26.9	28.9	23.6	24.3	26.3	28.2	22.4	23.1	25.0	26.8	20.8	21.4	23.1	24.8	
S/T	0.77	0.69	0.52	0.34	0.80	0.72	0.54	0.35	0.82	0.73	0.56	0.36	0.85	0.76	0.57	0.37	0.88	0.79	0.60	0.38	0.89	0.79	0.60	0.39	
ΔT	20	18	15	10	20	18	15	10	20	18	15	10	20	18	15	10	20	18	15	10	18	17	14	10	
kW	1.77	1.81	1.87	1.93	1.91	1.96	2.02	2.09	2.04	2.09	2.16	2.23	2.15	2.20	2.28	2.36	2.25	2.30	2.38	2.46	2.33	2.39	2.47	2.56	
Amps	7.4	7.6	7.8	8.1	8.0	8.2	8.4	8.7	8.6	8.8	9.1	9.4	9.2	9.4	9.7	10.0	9.7	10.0	10.3	10.6	10.3	10.5	10.8	11.2	
HI PR	234	252	266	278	263	283	299	311	299	322	340	354	340	366	387	403	383	412	435	454	423	455	481	501	
LO PR	104	111	121	129	110	117	128	136	114	122	133	141	120	128	139	148	126	134	146	156	130	138	151	161	

IDB = Entering Indoor Dry Bulb Temperature
 High and low pressures are measured at the liquid and suction access fittings.
 Design Subcooling, 10±3 °F @ the liquid access fitting connection AHRI 95 test conditions. Design Superheat 10±3 °F @ the compressor suction access fitting connection.
 Shaded area reflects ACCA (TVA) conditions.
 kW = total system power
 Amps: Unit amps (comp.+ evaporator + condenser fan motors)

IDB		OUTDOOR AMBIENT TEMPERATURE																								
		65				75				85				95				105				115				
		59	63	67	71	59	63	67	71	59	63	67	71	59	63	67	71	59	63	67	71	59	63	67	71	
		ENTERING INDOOR WET BULB TEMPERATURE																								
		AIRFLOW																								
70	1350	MBh	34.9	36.2	39.6	-	34.1	35.3	38.7	-	33.3	34.5	37.8	-	32.5	33.6	36.9	-	30.8	32.0	35.0	-	28.6	29.6	32.4	-
		S/T	0.74	0.62	0.43	-	0.76	0.64	0.44	-	0.78	0.65	0.45	-	0.81	0.68	0.47	-	0.84	0.70	0.49	-	0.85	0.71	0.49	-
	ΔT	18	15	12	-	18	15	12	-	18	15	12	-	18	15	12	-	18	15	12	-	16	14	11	-	
	kW	2.39	2.44	2.52	-	2.57	2.63	2.72	-	2.74	2.80	2.89	-	2.88	2.95	3.05	-	3.01	3.08	3.18	-	3.12	3.19	3.30	-	
	Amps	10.2	10.4	10.7	-	10.9	11.1	11.5	-	11.7	12.0	12.4	-	12.5	12.7	13.1	-	13.2	13.5	13.9	-	13.9	14.2	14.6	-	
	HI PR	248	267	282	-	278	299	316	-	316	341	360	-	360	388	410	-	405	436	461	-	448	482	509	-	
	LO PR	111	118	129	-	117	125	136	-	122	130	141	-	128	136	149	-	134	143	156	-	139	147	161	-	
	1200	MBh	33.9	35.1	38.5	-	33.1	34.3	37.6	-	32.3	33.5	36.7	-	31.5	32.7	35.8	-	29.9	31.0	34.0	-	27.7	28.7	31.5	-
		S/T	0.70	0.59	0.41	-	0.73	0.61	0.42	-	0.75	0.62	0.43	-	0.77	0.64	0.45	-	0.80	0.67	0.46	-	0.81	0.67	0.47	-
	ΔT	18	16	12	-	18	16	12	-	18	16	12	-	19	16	12	-	18	16	12	-	17	15	11	-	
kW	2.37	2.42	2.49	-	2.55	2.61	2.69	-	2.72	2.78	2.87	-	2.86	2.92	3.02	-	2.98	3.05	3.15	-	3.09	3.16	3.27	-		
Amps	10.1	10.3	10.6	-	10.8	11.0	11.4	-	11.6	11.9	12.3	-	12.4	12.6	13.0	-	13.1	13.4	13.8	-	13.8	14.1	14.5	-		
HI PR	245	264	279	-	275	296	313	-	313	337	356	-	357	384	405	-	401	432	456	-	444	477	504	-		
LO PR	110	117	127	-	116	123	135	-	121	128	140	-	127	135	147	-	133	141	154	-	137	146	159	-		
1050	MBh	31.3	32.4	35.5	-	30.5	31.6	34.7	-	29.8	30.9	33.8	-	29.1	30.1	33.0	-	27.6	28.6	31.4	-	25.6	26.5	29.1	-	
	S/T	0.68	0.57	0.39	-	0.70	0.59	0.41	-	0.72	0.60	0.42	-	0.74	0.62	0.43	-	0.77	0.64	0.45	-	0.78	0.65	0.45	-	
ΔT	19	16	12	-	19	16	12	-	19	16	12	-	19	16	12	-	19	16	12	-	17	15	11	-		
kW	2.31	2.36	2.43	-	2.49	2.54	2.63	-	2.65	2.71	2.80	-	2.79	2.85	2.95	-	2.91	2.97	3.07	-	3.01	3.08	3.18	-		
Amps	9.9	10.1	10.4	-	10.6	10.8	11.1	-	11.4	11.6	11.9	-	12.1	12.3	12.7	-	12.7	13.0	13.4	-	13.4	13.7	14.2	-		
HI PR	238	256	271	-	267	288	304	-	304	327	345	-	346	372	393	-	389	419	442	-	430	463	489	-		
LO PR	106	113	124	-	112	120	131	-	117	124	136	-	123	131	143	-	129	137	149	-	133	142	155	-		
75	1350	MBh	35.5	36.5	39.5	42.4	34.7	35.7	38.6	41.4	33.8	34.8	37.7	40.5	33.0	34.0	36.8	39.5	31.4	32.3	34.9	37.5	29.0	29.9	32.4	34.7
		S/T	0.84	0.75	0.57	0.36	0.87	0.78	0.59	0.38	0.89	0.80	0.60	0.39	0.92	0.82	0.62	0.40	0.95	0.85	0.65	0.42	0.96	0.86	0.65	0.42
	ΔT	20	19	15	11	20	19	15	11	21	19	15	11	21	19	16	11	20	19	15	11	19	18	14	10	
	kW	2.40	2.46	2.54	2.62	2.59	2.65	2.74	2.83	2.76	2.82	2.92	3.02	2.91	2.97	3.07	3.18	3.03	3.10	3.21	3.32	3.14	3.21	3.32	3.44	
	Amps	10.3	10.5	10.8	11.1	11.0	11.2	11.6	11.9	11.8	12.1	12.5	12.9	12.6	12.8	13.2	13.7	13.3	13.6	14.0	14.5	14.0	14.3	14.8	15.3	
	HI PR	250	270	285	297	281	302	319	333	320	344	363	379	364	392	414	431	410	441	465	485	453	487	514	536	
	LO PR	112	119	130	139	118	126	137	146	123	131	143	152	129	137	150	160	135	144	157	167	140	149	163	173	
	1200	MBh	34.4	35.5	38.4	41.2	33.6	34.6	37.5	40.2	32.8	33.8	36.6	39.3	32.0	33.0	35.7	38.3	30.4	31.3	33.9	36.4	28.2	29.0	31.4	33.7
		S/T	0.80	0.71	0.54	0.35	0.83	0.74	0.56	0.36	0.85	0.76	0.57	0.37	0.88	0.78	0.59	0.38	0.91	0.81	0.62	0.40	0.92	0.82	0.62	0.40
	ΔT	21	19	16	11	21	20	16	11	21	20	16	11	22	20	16	11	21	20	16	11	20	18	15	10	
kW	2.39	2.44	2.52	2.60	2.57	2.63	2.72	2.81	2.74	2.80	2.89	2.99	2.88	2.95	3.05	3.15	3.01	3.08	3.18	3.29	3.12	3.19	3.30	3.41		
Amps	10.2	10.4	10.7	11.0	10.9	11.1	11.5	11.8	11.7	12.0	12.4	12.8	12.5	12.7	13.1	13.6	13.2	13.5	13.9	14.4	13.9	14.2	14.7	15.2		
HI PR	248	267	282	294	278	299	316	330	316	341	360	375	360	388	410	427	406	436	461	481	448	482	509	531		
LO PR	111	118	129	137	117	125	136	145	122	130	141	151	128	136	149	158	134	143	156	166	139	148	161	171		
1050	MBh	31.8	32.7	35.4	38.0	31.1	32.0	34.6	37.1	30.3	31.2	33.8	36.3	29.6	30.4	33.0	35.4	28.1	28.9	31.3	33.6	26.0	26.8	29.0	31.1	
	S/T	0.77	0.69	0.52	0.34	0.80	0.71	0.54	0.35	0.82	0.73	0.55	0.36	0.85	0.76	0.57	0.37	0.88	0.78	0.59	0.38	0.88	0.79	0.60	0.39	
ΔT	21	20	16	11	22	20	16	11	22	20	16	11	22	20	17	11	22	20	16	11	20	19	15	10		
kW	2.33	2.38	2.45	2.53	2.51	2.56	2.65	2.74	2.67	2.73	2.82	2.91	2.81	2.87	2.97	3.07	2.93	3.00	3.10	3.21	3.04	3.11	3.21	3.32		
Amps	9.9	10.1	10.4	10.8	10.6	10.9	11.2	11.6	11.5	11.7	12.0	12.5	12.2	12.4	12.8	13.2	12.9	13.1	13.5	14.0	13.5	13.9	14.3	14.8		
HI PR	241	259	273	285	270	290	307	320	307	330	349	364	350	376	397	414	393	423	447	466	435	468	494	515		
LO PR	108	114	125	133	114	121	132	141	118	126	137	146	124	132	144	153	130	138	151	161	134	143	156	166		

IDB = Entering Indoor Dry Bulb Temperature
 High and low pressures are measured at the liquid and suction access fittings.
 Design Subcooling, 12±3 °F @ the liquid access fitting connection AHRI 95 test conditions. Design Superheat 13±3 °F @ the compressor suction access fitting connection.

Shaded area reflects ACCA (TVA) conditions.

kW = total system power

Amps: Unit amps (comp.+ evaporator + condenser fan motors)

IDB		OUTDOOR AMBIENT TEMPERATURE												ENTERING INDOOR WET BULB TEMPERATURE															
		65				75				85				95				105				115							
		59	63	67	71	59	63	67	71	59	63	67	71	59	63	67	71	59	63	67	71	59	63	67	71	59	63	67	71
80	AIRFLOW	36.1	36.9	39.4	42.1	35.3	36.0	38.5	41.2	34.4	35.2	37.6	40.2	33.6	34.3	36.7	39.2	31.9	32.6	34.8	37.2	29.6	30.2	32.3	34.5	29.6	30.2	32.3	34.5
	MBh	0.92	0.86	0.70	0.52	0.95	0.89	0.73	0.54	1.00	0.92	0.75	0.56	1.00	0.95	0.77	0.58	1.00	1.00	0.80	0.60	1.00	1.00	0.81	0.60	1.00	1.00	0.81	0.60
	S/T	23	22	19	15	23	22	19	15	23	22	19	15	23	22	19	15	22	22	19	15	20	21	18	14	20	21	18	14
	ΔT	2.42	2.48	2.56	2.64	2.62	2.67	2.76	2.85	2.79	2.85	2.94	3.04	2.93	3.00	3.10	3.21	3.06	3.13	3.24	3.35	3.17	3.24	3.35	3.47	3.17	3.24	3.35	3.47
	kW	10.3	10.6	10.9	11.2	11.1	11.3	11.7	12.0	11.9	12.2	12.6	13.0	12.7	13.0	13.3	13.8	13.4	13.7	14.1	14.6	14.1	14.5	14.9	15.4	14.1	14.5	14.9	15.4
	Amps	253	272	288	300	284	306	323	336	323	347	367	383	368	396	418	436	414	445	470	490	457	492	519	542	457	492	519	542
	HI PR	113	120	131	140	120	127	139	148	124	132	144	154	130	139	152	161	137	145	159	169	141	150	164	175	141	150	164	175
	LO PR	35.1	35.8	38.3	40.9	34.2	35.0	37.4	40.0	33.4	34.2	36.5	39.0	32.6	33.3	35.6	38.1	31.0	31.7	33.8	36.2	28.7	29.3	31.3	33.5	28.7	29.3	31.3	33.5
	MBh	0.88	0.82	0.67	0.50	0.91	0.85	0.69	0.52	0.93	0.87	0.71	0.53	0.96	0.90	0.73	0.55	1.00	0.94	0.76	0.57	1.00	0.94	0.77	0.57	1.00	0.94	0.77	0.57
	S/T	24	23	20	16	24	23	20	16	24	23	20	16	24	23	20	16	24	23	20	16	22	21	18	15	22	21	18	15
ΔT	2.41	2.46	2.54	2.62	2.59	2.65	2.74	2.83	2.76	2.82	2.92	3.02	2.91	2.98	3.08	3.18	3.04	3.10	3.21	3.32	3.14	3.22	3.32	3.44	3.14	3.22	3.32	3.44	
kW	10.3	10.5	10.8	11.1	11.0	11.2	11.6	11.9	11.8	12.1	12.5	12.9	12.6	12.8	13.2	13.7	13.3	13.6	14.0	14.5	14.0	14.3	14.8	15.3	14.0	14.3	14.8	15.3	
Amps	251	270	285	297	281	302	319	333	320	344	363	379	364	392	414	432	410	441	465	485	453	487	514	536	453	487	514	536	
HI PR	112	119	130	139	118	126	137	146	123	131	143	152	129	137	150	160	135	144	157	167	140	149	163	173	140	149	163	173	
LO PR	32.4	33.1	35.3	37.8	31.6	32.3	34.5	36.9	30.9	31.5	33.7	36.0	30.1	30.8	32.9	35.1	28.6	29.2	31.2	33.4	26.5	27.1	28.9	30.9	26.5	27.1	28.9	30.9	
MBh	0.84	0.79	0.65	0.48	0.88	0.82	0.67	0.50	0.90	0.84	0.69	0.51	0.93	0.87	0.71	0.53	0.96	0.90	0.73	0.55	0.97	0.91	0.74	0.55	0.97	0.91	0.74	0.55	
S/T	24	23	20	16	24	23	20	16	24	23	20	16	24	23	20	16	24	23	20	16	22	22	19	15	22	22	19	15	
ΔT	2.35	2.40	2.47	2.55	2.53	2.59	2.67	2.76	2.69	2.75	2.84	2.94	2.84	2.90	3.00	3.10	2.96	3.02	3.13	3.23	3.06	3.13	3.24	3.35	3.06	3.13	3.24	3.35	
kW	10.0	10.2	10.5	10.9	10.7	11.0	11.3	11.7	11.5	11.8	12.1	12.6	12.3	12.5	12.9	13.3	13.0	13.3	13.7	14.1	13.7	14.0	14.4	14.9	13.7	14.0	14.4	14.9	
Amps	243	261	276	288	273	293	310	323	310	334	352	368	353	380	401	419	397	428	452	471	439	472	499	520	439	472	499	520	
HI PR	109	116	126	134	115	122	133	142	119	127	139	148	125	133	146	155	131	140	153	162	136	145	158	168	136	145	158	168	
LO PR	36.7	37.4	39.2	41.8	35.9	36.6	38.3	40.9	35.0	35.7	37.4	39.9	34.2	34.8	36.5	38.9	32.5	33.1	34.7	37.0	30.1	30.7	32.1	34.3	30.1	30.7	32.1	34.3	
MBh	0.96	0.93	0.84	0.68	1.00	0.96	0.87	0.71	1.00	0.99	0.89	0.72	1.00	1.00	0.92	0.75	1.00	1.00	0.96	0.77	1.00	1.00	0.96	0.78	1.00	1.00	0.96	0.78	
S/T	24	24	22	19	24	24	23	20	24	24	23	20	23	24	23	20	22	23	20	16	20	21	18	15	20	21	18	15	
ΔT	2.44	2.50	2.58	2.66	2.64	2.70	2.78	2.88	2.81	2.87	2.97	3.07	2.96	3.03	3.13	3.23	3.09	3.16	3.26	3.38	3.20	3.27	3.38	3.50	3.20	3.27	3.38	3.50	
kW	10.4	10.6	11.0	11.3	11.2	11.4	11.7	12.1	12.0	12.3	12.7	13.1	12.8	13.1	13.5	13.9	13.5	13.8	14.3	14.7	14.3	14.6	15.0	15.6	14.3	14.6	15.0	15.6	
Amps	256	275	290	303	287	309	326	340	326	351	371	387	371	400	422	440	418	450	475	495	462	497	525	547	462	497	525	547	
HI PR	114	122	133	141	121	128	140	149	125	133	146	155	132	140	153	163	138	147	160	171	143	152	166	177	143	152	166	177	
LO PR	35.7	36.4	38.1	40.6	34.8	35.5	37.2	39.7	34.0	34.7	36.3	38.7	33.2	33.8	35.4	37.8	31.5	32.1	33.7	35.9	29.2	29.8	31.2	33.3	29.2	29.8	31.2	33.3	
MBh	0.92	0.89	0.80	0.65	0.95	0.92	0.83	0.67	0.98	0.94	0.85	0.69	1.00	0.97	0.88	0.71	1.00	1.00	0.91	0.74	1.00	1.00	0.92	0.75	1.00	1.00	0.92	0.75	
S/T	25	25	23	20	25	25	24	20	25	25	24	20	25	25	24	21	24	25	23	20	22	23	22	19	22	23	22	19	
ΔT	2.42	2.48	2.56	2.64	2.62	2.67	2.76	2.85	2.79	2.85	2.94	3.04	2.93	3.00	3.10	3.21	3.06	3.13	3.24	3.35	3.17	3.24	3.35	3.47	3.17	3.24	3.35	3.47	
kW	10.3	10.6	10.9	11.2	11.1	11.3	11.7	12.0	11.9	12.2	12.6	13.0	12.7	13.0	13.3	13.8	13.4	13.7	14.1	14.6	14.1	14.5	14.9	15.4	14.1	14.5	14.9	15.4	
Amps	253	272	288	300	284	306	323	336	323	347	367	383	368	396	418	436	414	445	470	490	457	492	519	542	457	492	519	542	
HI PR	113	120	131	140	120	127	139	148	124	132	144	154	130	139	152	161	137	145	159	169	141	150	164	175	141	150	164	175	
LO PR	32.9	33.6	35.1	37.5	32.2	32.8	34.3	36.6	31.4	32.0	33.5	35.8	30.6	31.2	32.7	34.9	29.1	29.7	31.1	33.1	26.9	27.5	28.8	30.7	26.9	27.5	28.8	30.7	
MBh	0.89	0.85	0.77	0.63	0.92	0.89	0.80	0.65	0.94	0.91	0.82	0.67	0.97	0.94	0.85	0.69	1.00	0.97	0.88	0.71	1.00	0.98	0.89	0.72	1.00	0.98	0.89	0.72	
S/T	26	25	24	21	26	25	24	21	26	25	24	21	26	26	24	21	25	25	24	21	24	24	22	19	24	24	22	19	
ΔT	2.37	2.42	2.49	2.58	2.55	2.61	2.69	2.78	2.71	2.78	2.87	2.96	2.86	2.92	3.02	3.12	2.98	3.05	3.15	3.26	3.09	3.16	3.27	3.38	3.09	3.16	3.27	3.38	
kW	10.1	10.3	10.6	11.0	10.8	11.0	11.4	11.7	11.6	11.9	12.2	12.7	12.4	12.6	13.0	13.5	13.1	13.4	13.8	14.2	13.8	14.1	14.5	15.0	13.8	14.1	14.5	15.0	
Amps	245	264	279	291	275	296	313	326	313	337	356	371	357	384	405	423	401	432	456	476	443	477	504	526	443	477	504	526	
HI PR	110	117	127	136	116	123	135	143	120	128	140	149	127	135	147	157	133	141	154	164	137	146	159	170	137	146	159	170	
LO PR	35.7	36.4	38.1	40.6	34.8	35.5	37.2	39.7	34.0	34.7	36.3	38.7	33.2	33.8	35.4	37.8	31.5	32.1	33.7	35.9	29.2	29.8	31.2	33.3	29.2	29.8	31.2	33.3	

IDB = Entering Indoor Dry Bulb Temperature

High and low pressures are measured at the liquid and suction access fittings.

Design Subcooling, 12±3 °F @ the liquid access fitting connection AHRI 95 test conditions. Design Superheat: 13±3 °F @ the compressor suction access fitting connection.

Shaded area reflects AHRI conditions.

Amps: Unit amps (comp. + evaporator + condenser fan motors)

kW = total system power

IDB		OUTDOOR AMBIENT TEMPERATURE												ENTERING INDOOR WET BULB TEMPERATURE												
		65				75				85				95				105				115				
		59	63	67	71	59	63	67	71	59	63	67	71	59	63	67	71	59	63	67	71	59	63	67	71	
70	1460	MBh	39.2	40.6	44.5	-	38.3	39.7	43.5	-	37.4	38.7	42.4	-	36.5	37.8	41.4	-	34.6	35.9	39.3	-	32.1	33.3	36.4	-
		S/T	0.71	0.59	0.41	-	0.74	0.62	0.43	-	0.76	0.63	0.44	-	0.78	0.65	0.45	-	0.81	0.68	0.47	-	0.82	0.68	0.47	-
	ΔT	18	15	12	-	18	15	12	-	18	15	12	-	18	16	12	-	18	15	12	-	17	14	11	-	
	kW	2.53	2.58	2.66	-	2.72	2.78	2.87	-	2.90	2.96	3.06	-	3.05	3.12	3.22	-	3.18	3.25	3.36	-	3.29	3.36	3.48	-	
	Amps	11.0	11.2	11.5	-	11.8	12.0	12.4	-	12.7	13.0	13.3	-	13.5	13.8	14.2	-	14.3	14.6	15.0	-	15.0	15.4	15.8	-	
	HI PR	236	254	269	-	265	285	301	-	302	325	343	-	344	370	390	-	387	416	439	-	427	460	485	-	
	LO PR	110	117	128	-	116	124	135	-	121	128	140	-	127	135	147	-	133	141	154	-	138	146	160	-	
	MBh	38.1	39.4	43.2	-	37.2	38.5	42.2	-	36.3	37.6	41.2	-	35.4	36.7	40.2	-	33.6	34.9	38.2	-	31.2	32.3	35.4	-	
	S/T	0.68	0.57	0.39	-	0.70	0.59	0.41	-	0.72	0.60	0.42	-	0.74	0.62	0.43	-	0.77	0.65	0.45	-	0.78	0.65	0.45	-	
	ΔT	18	16	12	-	18	16	12	-	19	16	12	-	19	16	12	-	19	16	12	-	17	15	11	-	
kW	2.51	2.56	2.64	-	2.70	2.76	2.85	-	2.87	2.94	3.03	-	3.02	3.09	3.19	-	3.15	3.22	3.33	-	3.26	3.34	3.45	-		
Amps	10.9	11.1	11.5	-	11.7	11.9	12.3	-	12.6	12.9	13.2	-	13.4	13.7	14.1	-	14.1	14.4	14.9	-	14.9	15.2	15.7	-		
HI PR	234	252	266	-	263	283	298	-	299	321	339	-	340	366	387	-	383	412	435	-	423	455	481	-		
LO PR	109	116	126	-	115	122	134	-	120	127	139	-	126	134	146	-	132	140	153	-	136	145	158	-		
MBh	35.1	36.4	39.9	-	34.3	35.6	39.0	-	33.5	34.7	38.0	-	32.7	33.9	37.1	-	31.0	32.2	35.2	-	28.8	29.8	32.7	-		
S/T	0.65	0.55	0.38	-	0.68	0.57	0.39	-	0.70	0.58	0.40	-	0.72	0.60	0.42	-	0.75	0.62	0.43	-	0.75	0.63	0.43	-		
ΔT	19	16	12	-	19	16	12	-	19	16	12	-	19	16	12	-	19	16	12	-	17	15	11	-		
kW	2.45	2.50	2.58	-	2.64	2.69	2.78	-	2.80	2.86	2.96	-	2.95	3.01	3.11	-	3.07	3.14	3.24	-	3.18	3.25	3.36	-		
Amps	10.6	10.9	11.2	-	11.4	11.6	12.0	-	12.3	12.5	12.9	-	13.0	13.3	13.7	-	13.8	14.1	14.5	-	14.5	14.8	15.3	-		
HI PR	227	244	258	-	255	274	290	-	290	312	329	-	330	355	375	-	371	400	422	-	410	441	466	-		
LO PR	106	112	123	-	112	119	130	-	116	123	135	-	122	130	141	-	128	136	148	-	132	140	153	-		
75	1460	MBh	39.9	41.0	44.4	47.7	38.9	40.1	43.4	46.6	38.0	39.1	42.4	45.5	37.1	38.2	41.3	44.4	35.2	36.3	39.3	42.1	32.6	33.6	36.4	39.0
		S/T	0.81	0.72	0.55	0.35	0.84	0.75	0.57	0.37	0.86	0.77	0.58	0.37	0.89	0.79	0.60	0.39	0.92	0.82	0.62	0.40	0.93	0.83	0.63	0.40
	ΔT	20	19	15	11	21	19	16	11	21	19	16	11	21	19	16	11	21	19	15	11	19	18	14	10	
	kW	2.55	2.60	2.69	2.77	2.75	2.81	2.90	2.99	2.92	2.98	3.08	3.19	3.07	3.14	3.25	3.36	3.21	3.28	3.39	3.50	3.32	3.39	3.51	3.63	
	Amps	11.1	11.3	11.6	12.0	11.9	12.1	12.5	12.9	12.8	13.1	13.5	13.9	13.6	13.9	14.3	14.8	14.4	14.7	15.1	15.7	15.2	15.5	16.0	16.5	
	HI PR	239	257	271	283	268	288	305	318	305	328	346	361	347	374	394	411	391	420	444	463	431	464	490	511	
	LO PR	111	118	129	137	117	125	136	145	122	130	142	151	128	136	149	159	134	143	156	166	139	148	161	172	
	MBh	38.7	39.8	43.1	46.3	37.8	38.9	42.1	45.2	36.9	38.0	41.1	44.1	36.0	37.1	40.1	43.1	34.2	35.2	38.1	40.9	31.7	32.6	35.3	37.9	
	S/T	0.77	0.69	0.52	0.34	0.80	0.72	0.54	0.35	0.82	0.73	0.56	0.36	0.85	0.76	0.57	0.37	0.88	0.79	0.59	0.38	0.89	0.79	0.60	0.39	
	ΔT	21	19	16	11	21	20	16	11	21	20	16	11	22	20	16	11	21	20	16	11	20	18	15	10	
kW	2.53	2.58	2.66	2.75	2.72	2.78	2.87	2.97	2.90	2.96	3.06	3.16	3.05	3.12	3.22	3.33	3.18	3.25	3.36	3.47	3.29	3.36	3.48	3.60		
Amps	11.0	11.2	11.6	11.9	11.8	12.0	12.4	12.8	12.7	13.0	13.4	13.8	13.5	13.8	14.2	14.7	14.3	14.6	15.0	15.5	15.0	15.4	15.8	16.4		
HI PR	236	254	269	280	265	286	302	314	302	325	343	358	344	370	391	407	387	416	439	458	427	460	485	506		
LO PR	110	117	128	136	116	124	135	144	121	129	140	149	127	135	147	157	133	141	154	164	138	146	160	170		
MBh	35.7	36.8	39.8	42.7	34.9	35.9	38.9	41.7	34.1	35.1	38.0	40.7	33.2	34.2	37.0	39.7	31.6	32.5	35.2	37.8	29.2	30.1	32.6	35.0		
S/T	0.74	0.67	0.50	0.32	0.77	0.69	0.52	0.34	0.79	0.71	0.54	0.34	0.82	0.73	0.55	0.36	0.85	0.76	0.57	0.37	0.85	0.76	0.58	0.37		
ΔT	21	20	16	11	22	20	16	11	22	20	16	11	22	20	16	11	22	20	16	11	20	19	15	10		
kW	2.47	2.52	2.60	2.68	2.66	2.72	2.80	2.89	2.83	2.89	2.98	3.08	2.97	3.04	3.14	3.24	3.10	3.17	3.27	3.38	3.21	3.28	3.39	3.50		
Amps	10.7	11.0	11.3	11.6	11.5	11.7	12.1	12.5	12.4	12.6	13.0	13.5	13.1	13.4	13.8	14.3	13.9	14.2	14.6	15.1	14.6	15.0	15.4	16.0		
HI PR	229	247	261	272	257	277	292	305	293	315	333	347	333	359	379	395	375	404	426	445	414	446	471	491		
LO PR	107	114	124	132	113	120	131	139	117	125	136	145	123	131	143	152	129	137	150	160	133	142	155	165		

IDB = Entering Indoor Dry Bulb Temperature
 High and low pressures are measured at the liquid and suction access fittings.
 Design Subcooling, 12±3 °F @ the liquid access fitting connection AHRI 95 test conditions. Design Superheat 8±3 °F @ the compressor suction access fitting connection.
 Shaded area reflects ACCA (TVA) conditions.
 kW = total system power
 Amps: Unit amps (comp.+ evaporator + condenser fan motors)

IDB	Airflow	OUTDOOR AMBIENT TEMPERATURE																							
		65				75				85				95				105				115			
		59	63	67	71	59	63	67	71	59	63	67	71	59	63	67	71	59	63	67	71	59	63	67	71
80	MBh	40.6	41.5	44.3	47.3	39.6	40.5	43.3	46.2	38.7	39.5	42.2	45.1	37.7	38.6	41.2	44.0	35.9	36.6	39.1	41.8	33.2	33.9	36.3	38.8
	S/T	0.89	0.83	0.68	0.51	0.92	0.86	0.70	0.52	0.94	0.88	0.72	0.54	1.00	0.91	0.74	0.56	1.00	0.95	0.77	0.58	1.00	0.96	0.78	0.58
	ΔT	23	22	19	15	23	22	19	15	23	22	19	15	24	22	19	15	23	22	19	15	21	20	18	14
	kW	2.57	2.62	2.71	2.80	2.77	2.83	2.92	3.02	2.94	3.01	3.11	3.21	3.10	3.17	3.27	3.38	3.23	3.30	3.42	3.53	3.35	3.42	3.54	3.66
	Amps	11.2	11.4	11.7	12.1	12.0	12.2	12.6	13.0	12.9	13.2	13.6	14.0	13.7	14.0	14.4	14.9	14.5	14.8	15.3	15.8	15.3	15.6	16.1	16.7
	HI PR	241	260	274	286	271	291	308	321	308	331	350	365	351	377	398	416	394	424	448	468	436	469	495	517
	LO PR	112	119	130	139	119	126	138	147	123	131	143	152	128	136	149	159	136	144	158	168	140	149	163	174
	MBh	39.4	40.2	43.0	46.0	38.5	39.3	42.0	44.9	37.6	38.4	41.0	43.8	36.6	37.4	40.0	42.8	34.8	35.6	38.0	40.6	32.2	32.9	35.2	37.6
	S/T	0.85	0.79	0.65	0.48	0.88	0.82	0.67	0.50	0.90	0.84	0.69	0.51	0.93	0.87	0.71	0.53	0.96	0.90	0.74	0.55	0.97	0.91	0.74	0.55
	ΔT	24	23	20	16	24	23	20	16	24	23	20	16	24	23	20	16	24	23	20	16	22	21	18	15
kW	2.55	2.60	2.69	2.77	2.75	2.81	2.90	2.99	2.92	2.99	3.08	3.19	3.07	3.14	3.25	3.36	3.21	3.28	3.39	3.50	3.32	3.39	3.51	3.63	
Amps	11.1	11.3	11.6	12.0	11.9	12.1	12.5	12.9	12.8	13.1	13.5	13.9	13.6	13.9	14.3	14.8	14.4	14.7	15.1	15.7	15.2	15.5	16.0	16.5	
HI PR	239	257	271	283	268	288	305	318	305	328	346	361	347	374	395	411	391	420	444	463	432	464	490	511	
LO PR	111	118	129	137	117	125	136	145	122	130	142	151	128	136	149	159	134	143	156	166	139	148	161	172	
MBh	36.4	37.1	39.7	42.4	35.5	36.3	38.8	41.4	34.7	35.4	37.8	40.5	33.8	34.6	36.9	39.5	32.1	32.8	35.1	37.5	29.8	30.4	32.5	34.7	
S/T	0.82	0.77	0.62	0.47	0.85	0.79	0.65	0.48	0.87	0.81	0.66	0.49	0.90	0.84	0.68	0.51	0.93	0.87	0.71	0.53	0.94	0.88	0.72	0.53	
ΔT	24	23	20	16	24	23	20	16	24	23	20	16	24	23	20	16	24	23	20	16	22	22	19	15	
kW	2.49	2.54	2.62	2.71	2.68	2.74	2.83	2.92	2.85	2.91	3.01	3.11	3.00	3.06	3.16	3.27	3.12	3.19	3.30	3.41	3.23	3.31	3.42	3.53	
Amps	10.8	11.0	11.4	11.7	11.6	11.8	12.2	12.6	12.5	12.7	13.1	13.6	13.2	13.5	13.9	14.4	14.0	14.3	14.8	15.3	14.8	15.1	15.6	16.1	
HI PR	232	249	263	275	260	280	295	308	296	318	336	350	337	362	383	399	379	408	430	449	419	450	476	496	
LO PR	108	115	125	133	114	121	132	141	118	126	137	146	124	132	144	154	130	139	151	161	135	143	157	167	

85	MBh	41.3	42.1	44.1	47.0	40.3	41.1	43.0	45.9	39.4	40.1	42.0	44.8	38.4	39.1	41.0	43.7	36.5	37.2	38.9	41.5	33.8	34.4	36.1	38.5
	S/T	0.93	0.90	0.81	0.66	0.96	0.93	0.84	0.68	0.99	0.95	0.86	0.70	1.00	0.98	0.89	0.72	1.00	1.00	0.92	0.75	1.00	1.00	0.93	0.75
	ΔT	24	24	22	19	24	24	23	20	25	24	23	20	24	24	23	20	23	23	20	17	21	22	21	18
	kW	2.59	2.65	2.73	2.82	2.79	2.85	2.94	3.04	2.97	3.03	3.13	3.24	3.13	3.20	3.30	3.41	3.26	3.33	3.44	3.56	3.37	3.45	3.57	3.69
	Amps	11.3	11.5	11.8	12.2	12.1	12.3	12.7	13.1	13.0	13.3	13.7	14.2	13.8	14.1	14.5	15.1	14.6	14.9	15.4	15.9	15.4	15.8	16.3	16.8
	HI PR	244	262	277	289	273	294	311	324	311	335	353	369	354	381	402	420	398	429	453	472	440	474	500	522
	LO PR	113	121	132	140	120	127	139	148	124	132	145	154	131	139	152	162	137	146	159	169	142	151	165	175
	MBh	40.1	40.9	42.8	45.6	39.1	39.9	41.8	44.6	38.2	39.0	40.8	43.5	37.3	38.0	39.8	42.5	35.4	36.1	37.8	40.3	32.8	33.4	35.0	37.4
	S/T	0.89	0.86	0.77	0.63	0.92	0.89	0.80	0.65	0.94	0.91	0.82	0.67	0.97	0.94	0.85	0.69	1.00	0.97	0.88	0.71	1.00	0.98	0.89	0.72
	ΔT	25	25	23	20	25	25	24	20	25	25	24	21	26	25	24	21	25	25	24	20	23	23	22	19
kW	2.57	2.62	2.71	2.80	2.77	2.83	2.92	3.02	2.94	3.01	3.11	3.21	3.10	3.17	3.27	3.38	3.23	3.30	3.42	3.53	3.35	3.42	3.54	3.66	
Amps	11.2	11.4	11.7	12.1	12.0	12.2	12.6	13.0	12.9	13.2	13.6	14.0	13.7	14.0	14.4	14.9	14.5	14.8	15.3	15.8	15.3	15.6	16.1	16.7	
HI PR	241	260	274	286	271	291	308	321	308	331	350	365	351	377	398	416	394	424	448	468	436	469	495	517	
LO PR	112	119	130	139	119	126	138	147	123	131	143	152	129	138	150	160	136	144	158	168	140	149	163	174	
MBh	37.0	37.7	39.5	42.1	36.1	36.8	38.6	41.2	35.3	36.0	37.7	40.2	34.4	35.1	36.7	39.2	32.7	33.3	34.9	37.2	30.3	30.9	32.3	34.5	
S/T	0.86	0.83	0.75	0.60	0.89	0.86	0.77	0.63	0.91	0.88	0.79	0.64	0.94	0.91	0.82	0.66	0.97	0.94	0.85	0.69	0.98	0.95	0.86	0.69	
ΔT	26	25	24	21	26	25	24	21	26	25	24	21	26	26	24	21	26	25	24	21	24	24	22	19	
kW	2.51	2.56	2.64	2.73	2.70	2.76	2.85	2.94	2.87	2.93	3.03	3.13	3.02	3.09	3.19	3.30	3.15	3.22	3.33	3.44	3.26	3.33	3.45	3.56	
Amps	10.9	11.1	11.5	11.8	11.7	11.9	12.3	12.7	12.6	12.9	13.2	13.7	13.4	13.6	14.1	14.5	14.1	14.4	14.9	15.4	14.9	15.2	15.7	16.3	
HI PR	234	252	266	277	263	283	298	311	299	321	339	354	340	366	386	403	383	412	435	453	423	455	480	501	
LO PR	109	116	126	135	115	122	134	142	120	127	139	148	126	134	146	155	132	140	153	163	136	145	158	168	

IDB = Entering Indoor Dry Bulb Temperature

High and low pressures are measured at the liquid and suction access fittings.

Design Subcooling, 12.43 °F @ the liquid access fitting connection AHRI 95 test conditions. Design Superheat 8.43 °F @ the compressor suction access fitting connection.

Shaded area reflects AHRI conditions.

Amps: Unit amps (comp.+ evaporator + condenser fan motors)

kW = total system power

IDB	AIRFLOW	OUTDOOR AMBIENT TEMPERATURE												105												115											
		65						75						85						95						105						115					
		59	63	67	71	59	63	67	71	59	63	67	71	59	63	67	71	59	63	67	71	59	63	67	71	59	63	67	71	59	63	67	71				
70	1800	MBh	45.1	46.7	51.2	-	44.0	45.6	50.0	-	43.0	44.5	48.8	-	41.9	43.5	47.6	-	39.8	41.3	45.2	-	36.9	38.2	41.9	-	40.5	41.7	45.1	48.5	37.5	38.6	41.8	44.9			
		S/T	0.76	0.64	0.44	-	0.79	0.66	0.46	-	0.81	0.68	0.47	-	0.84	0.70	0.49	-	0.87	0.73	0.50	-	0.88	0.73	0.51	-	0.99	0.89	0.67	0.43	1.00	0.89	0.68	0.43			
	ΔT	18	15	12	-	18	15	12	-	18	15	12	-	18	16	12	-	18	15	12	-	17	14	11	-	20	19	15	11	19	18	14	10				
	kW	2.89	2.95	3.04	-	3.11	3.18	3.28	-	3.30	3.37	3.48	-	3.47	3.55	3.66	-	3.62	3.69	3.82	-	3.74	3.82	3.95	-	3.65	3.73	3.85	3.98	3.77	3.85	3.98	4.11				
	Amps	14.0	14.3	14.7	-	14.9	15.2	15.6	-	15.9	16.3	16.7	-	16.8	17.2	17.6	-	17.7	18.1	18.6	-	18.6	19.0	19.5	-	17.8	18.2	18.7	19.3	18.7	19.1	19.7	20.3				
	HI PR	232	250	264	-	260	280	296	-	296	318	336	-	337	363	383	-	379	408	431	-	419	451	476	-	423	455	481	502	423	455	481	502				
	LO PR	111	118	128	-	117	124	136	-	121	129	141	-	128	136	148	-	134	142	155	-	138	147	161	-	140	149	162	173	140	149	162	173				
	MBh	43.8	45.4	49.7	-	42.7	44.3	48.5	-	41.7	43.2	47.4	-	40.7	42.2	46.2	-	38.7	40.1	43.9	-	35.8	37.1	40.7	-	39.3	40.5	43.8	47.0	36.4	37.5	40.6	43.6				
	S/T	0.73	0.61	0.42	-	0.76	0.63	0.44	-	0.78	0.65	0.45	-	0.80	0.67	0.46	-	0.83	0.69	0.48	-	0.84	0.70	0.48	-	0.94	0.84	0.64	0.41	0.95	0.85	0.64	0.41				
	ΔT	18	16	12	-	19	16	12	-	19	16	12	-	19	16	12	-	18	16	12	-	17	15	11	-	20	19	15	11	20	18	14	10				
kW	2.87	2.93	3.02	-	3.09	3.15	3.25	-	3.28	3.35	3.45	-	3.44	3.52	3.63	-	3.59	3.66	3.78	-	3.71	3.79	3.92	-	3.62	3.70	3.82	3.95	3.62	3.70	3.82	3.95					
Amps	13.9	14.2	14.6	-	14.8	15.1	15.5	-	15.8	16.1	16.6	-	16.7	17.0	17.5	-	17.6	17.9	18.4	-	18.4	18.8	19.3	-	17.2	17.5	18.0	18.6	18.0	18.4	18.9	19.5					
HI PR	230	247	261	-	258	277	293	-	293	315	333	-	334	359	379	-	375	404	427	-	415	446	471	-	423	455	481	502	423	455	481	502					
LO PR	110	117	127	-	116	123	134	-	120	128	140	-	126	134	147	-	132	141	154	-	137	146	159	-	140	149	162	173	140	149	162	173					
MBh	40.4	41.9	45.9	-	39.5	40.9	44.8	-	38.5	39.9	43.7	-	37.6	38.9	42.7	-	35.7	37.0	40.5	-	33.1	34.3	37.5	-	39.3	40.5	43.8	47.0	36.4	37.5	40.6	43.6					
S/T	0.70	0.59	0.41	-	0.73	0.61	0.42	-	0.75	0.62	0.43	-	0.77	0.64	0.45	-	0.80	0.67	0.46	-	0.81	0.67	0.47	-	0.94	0.84	0.64	0.41	0.95	0.85	0.64	0.41					
ΔT	19	16	12	-	19	16	12	-	19	16	12	-	19	16	12	-	18	16	12	-	17	15	11	-	20	19	15	11	20	18	14	10					
kW	2.80	2.86	2.95	-	3.01	3.08	3.17	-	3.20	3.27	3.37	-	3.36	3.43	3.54	-	3.50	3.57	3.69	-	3.62	3.70	3.82	-	3.62	3.70	3.82	3.95	3.62	3.70	3.82	3.95					
Amps	13.6	13.9	14.3	-	14.5	14.8	15.2	-	15.5	15.8	16.2	-	16.3	16.6	17.1	-	17.2	17.5	18.0	-	18.0	18.4	18.9	-	17.2	17.5	18.0	18.6	18.0	18.4	18.9	19.5					
HI PR	223	240	253	-	250	269	284	-	284	306	323	-	324	348	368	-	364	392	414	-	402	433	457	-	423	455	481	502	423	455	481	502					
LO PR	106	113	123	-	112	119	130	-	117	124	135	-	123	130	142	-	128	137	149	-	133	141	154	-	140	149	162	173	140	149	162	173					
75	1800	MBh	45.8	47.2	51.1	54.8	44.8	46.1	49.9	53.6	43.7	45.0	48.7	52.3	42.6	43.9	47.5	51.0	40.5	41.7	45.1	48.5	37.5	38.6	41.8	44.9	40.5	41.7	45.1	48.5	37.5	38.6	41.8	44.9			
		S/T	0.87	0.78	0.59	0.38	0.90	0.81	0.61	0.39	0.92	0.83	0.63	0.40	0.95	0.85	0.65	0.42	0.99	0.89	0.67	0.43	1.00	0.89	0.68	0.43	0.99	0.89	0.67	0.43	1.00	0.89	0.68	0.43			
	ΔT	20	19	15	11	21	19	16	11	21	19	16	11	21	19	16	11	22	20	19	15	11	19	18	14	10	20	19	15	11	20	18	14	10			
	kW	2.92	2.98	3.07	3.16	3.14	3.20	3.30	3.41	3.33	3.40	3.51	3.62	3.50	3.58	3.69	3.81	3.65	3.73	3.85	3.98	3.77	3.85	3.98	4.11	3.65	3.73	3.85	3.98	3.77	3.85	3.98	4.11				
	Amps	14.1	14.4	14.8	15.2	15.0	15.3	15.7	16.2	16.1	16.4	16.8	17.3	17.0	17.3	17.8	18.3	17.8	18.2	18.7	19.3	18.7	19.1	19.7	20.3	17.8	18.2	18.7	19.3	18.7	19.1	19.7	20.3				
	HI PR	234	252	266	278	263	283	299	312	299	322	340	354	340	366	387	404	383	412	435	454	423	455	481	502	423	455	481	502	423	455	481	502				
	LO PR	112	119	130	138	118	126	137	146	123	131	143	152	129	137	150	159	135	144	157	167	140	149	162	173	140	149	162	173	140	149	162	173				
	MBh	44.5	45.8	49.6	53.2	43.5	44.8	48.4	52.0	42.4	43.7	47.3	50.8	41.4	42.6	46.1	49.5	39.3	40.5	43.8	47.0	36.4	37.5	40.6	43.6	39.3	40.5	43.8	47.0	36.4	37.5	40.6	43.6				
	S/T	0.83	0.74	0.56	0.36	0.86	0.77	0.58	0.37	0.88	0.79	0.60	0.38	0.91	0.81	0.62	0.40	0.94	0.84	0.64	0.41	0.95	0.85	0.64	0.41	0.94	0.84	0.64	0.41	0.95	0.85	0.64	0.41				
	ΔT	21	20	16	11	21	20	16	11	21	20	16	11	22	20	16	11	22	20	16	11	20	18	15	10	21	20	16	11	20	18	15	10				
kW	2.89	2.95	3.04	3.14	3.11	3.18	3.28	3.38	3.30	3.37	3.48	3.59	3.47	3.55	3.66	3.78	3.62	3.70	3.82	3.94	3.74	3.82	3.95	4.08	3.62	3.70	3.82	3.94	3.74	3.82	3.95	4.08					
Amps	14.0	14.3	14.7	15.1	14.9	15.2	15.6	16.1	15.9	16.3	16.7	17.2	16.8	17.2	17.6	18.2	17.7	18.1	18.6	19.2	18.6	19.0	19.5	20.1	17.7	18.1	18.6	19.2	18.6	19.0	19.5	20.1					
HI PR	232	250	264	275	260	280	296	308	296	319	336	351	337	363	383	400	379	408	431	449	419	451	476	497	423	455	481	502	419	451	476	497					
LO PR	111	118	128	137	117	124	136	145	121	129	141	150	128	136	148	158	134	142	155	165	138	147	161	171	140	149	162	173	138	147	161	171					
MBh	41.1	42.3	45.8	49.1	40.1	41.3	44.7	48.0	39.2	40.3	43.7	46.8	38.2	39.3	42.6	45.7	36.3	37.4	40.5	43.4	33.6	34.6	37.5	40.2	36.3	37.4	40.5	43.4	33.6	34.6	37.5	40.2					
S/T	0.80	0.72	0.54	0.35	0.83	0.74	0.56	0.36	0.85	0.76	0.58	0.37	0.88	0.78	0.59	0.38	0.91	0.81	0.62	0.40	0.92	0.82	0.62	0.40	0.91	0.81	0.62	0.40	0.92	0.82	0.62	0.40					
ΔT	22	20	16	11	22	20	16	11	22	20	16	11	22	20	16	11	22	20	16	11	20	19	15	11	22	20	16	11	20	19	15	11					
kW	2.83	2.88	2.97	3.07	3.04	3.10	3.20	3.30	3.22	3.29	3.40	3.51	3.39	3.46	3.57	3.69	3.53	3.60	3.72	3.84	3.65	3.73	3.85	3.98	3.53	3.60	3.72	3.84	3.65	3.73	3.85	3.98					
Amps	13.7	14.0	14.4	14.8	14.6	14.9	15.3	15.7	15.6	15.9	16.3	16.8	16.4	16.8	17.2	17.8	17.3	17.7	18.1	18.7	18.2	18.5	19.0	19.7	17.3	17.7	18.1	18.7	18.2	18.5	19.0	19.7					
HI PR	225	242	256	267	252	272	287	299	287	309	326	340	327	352	372	388	368	396	418	436	406	437	462	482	423	455	481	502	406	437	462	482					
LO PR	107	114	125	133	113	121	132	140	118	125	137	146	124	132	144	153	130	138	151	160	134	143	156	166	140	149	162	173	134	143	156	166					

IDB = Entering Indoor Dry Bulb Temperature
 High and low pressures are measured at the liquid and suction access fittings.
 Design Subcooling, 10±3 °F @ the liquid access fitting connection AHRI 95 test conditions. Design Superheat 12±3 °F @ the compressor suction access fitting connection.
 Shaded area reflects ACCA (TVA) conditions.
 kW = total system power
 Amps: Unit amps (comp.+ evaporator + condenser fan motors)

IDB	AIRFLOW	OUTDOOR AMBIENT TEMPERATURE																								
		65				75				85				95				105				115				
		59	63	67	71	59	63	67	71	59	63	67	71	59	63	67	71	59	63	67	71	59	63	67	71	
70	1800	MBh	56.3	58.4	64.0	-	55.0	57.0	62.5	-	53.7	55.7	61.0	-	52.4	54.3	59.5	-	49.8	51.6	56.5	-	46.1	47.8	52.4	-
		S/T	0.72	0.60	0.42	-	0.75	0.62	0.43	-	0.77	0.64	0.44	-	0.79	0.66	0.46	-	0.82	0.69	0.47	-	0.83	0.69	0.48	-
		ΔT	21	18	14	-	21	18	14	-	21	18	14	-	21	18	14	-	21	18	14	-	20	17	13	-
		kW	3.87	3.96	4.09	-	4.18	4.28	4.42	-	4.46	4.56	4.71	-	4.70	4.81	4.97	-	4.90	5.02	5.19	-	5.08	5.20	5.38	-
		Amps	17.7	18.0	18.6	-	18.9	19.3	19.9	-	20.4	20.8	21.5	-	21.7	22.1	22.8	-	22.9	23.4	24.2	-	24.2	24.7	25.5	-
	1600	HI PR	250	269	284	-	280	302	318	-	319	343	362	-	363	391	413	-	408	440	464	-	451	486	513	-
		LO PR	103	110	120	-	109	116	127	-	113	121	132	-	119	127	138	-	125	133	145	-	129	137	150	-
		MBh	54.7	56.7	62.1	-	53.4	55.4	60.7	-	52.2	54.1	59.2	-	50.9	52.7	57.8	-	48.3	50.1	54.9	-	44.8	46.4	50.9	-
		S/T	0.69	0.57	0.40	-	0.71	0.60	0.41	-	0.73	0.61	0.42	-	0.75	0.63	0.44	-	0.78	0.65	0.45	-	0.79	0.66	0.46	-
		ΔT	22	19	14	-	22	19	14	-	22	19	14	-	22	19	14	-	22	19	14	-	20	18	13	-
1400	kW	3.84	3.93	4.05	-	4.15	4.24	4.38	-	4.42	4.52	4.67	-	4.66	4.77	4.93	-	4.86	4.97	5.14	-	5.04	5.15	5.33	-	
	Amps	17.5	17.9	18.4	-	18.8	19.2	19.7	-	20.2	20.7	21.3	-	21.5	22.0	22.6	-	22.7	23.2	23.9	-	24.0	24.5	25.3	-	
	HI PR	247	266	281	-	277	299	315	-	316	340	359	-	359	387	408	-	404	435	460	-	447	481	508	-	
	LO PR	102	109	119	-	108	115	125	-	112	119	130	-	118	125	137	-	124	132	144	-	128	136	149	-	
	MBh	50.5	52.3	57.3	-	49.3	51.1	56.0	-	48.1	49.9	54.7	-	47.0	48.7	53.3	-	44.6	46.2	50.7	-	41.3	42.8	46.9	-	

IDB	AIRFLOW	OUTDOOR AMBIENT TEMPERATURE																								
		65				75				85				95				105				115				
		59	63	67	71	59	63	67	71	59	63	67	71	59	63	67	71	59	63	67	71	59	63	67	71	
75	1800	MBh	57.3	59.0	63.9	68.5	56.0	57.6	62.4	66.9	54.6	56.3	60.9	65.3	53.3	54.9	59.4	63.8	50.6	52.1	56.4	60.6	46.9	48.3	52.3	56.1
		S/T	0.82	0.73	0.55	0.36	0.85	0.76	0.57	0.37	0.87	0.78	0.59	0.38	0.90	0.80	0.61	0.39	0.93	0.83	0.63	0.41	0.94	0.84	0.64	0.41
		ΔT	24	22	18	12	24	22	18	13	24	22	18	13	24	23	19	13	24	22	18	13	23	21	17	12
		kW	3.91	3.99	4.12	4.26	4.22	4.31	4.46	4.61	4.50	4.60	4.75	4.92	4.74	4.85	5.01	5.19	4.95	5.06	5.24	5.42	5.13	5.25	5.43	5.62
		Amps	17.8	18.2	18.7	19.3	19.1	19.5	20.1	20.8	20.6	21.0	21.6	22.4	21.8	22.3	23.0	23.8	23.1	23.6	24.4	25.2	24.4	24.9	25.7	26.6
	1600	HI PR	252	272	287	299	283	305	322	336	322	347	366	382	367	395	417	435	413	444	469	489	456	491	518	540
		LO PR	104	111	121	129	110	117	128	136	115	122	133	142	120	128	140	149	126	134	146	156	130	139	152	161
		MBh	55.6	57.3	62.0	66.5	54.3	55.9	60.6	65.0	53.0	54.6	59.1	63.4	51.8	53.3	57.7	61.9	49.2	50.6	54.8	58.8	45.5	46.9	50.8	54.5
		S/T	0.78	0.70	0.53	0.34	0.81	0.72	0.55	0.35	0.83	0.74	0.56	0.36	0.86	0.77	0.58	0.37	0.89	0.80	0.60	0.39	0.90	0.80	0.61	0.39
		ΔT	25	23	19	13	25	23	19	13	25	23	19	13	25	23	19	13	25	23	19	13	23	22	18	12
1400	kW	3.87	3.96	4.09	4.23	4.18	4.28	4.42	4.57	4.46	4.56	4.71	4.87	4.70	4.81	4.97	5.14	4.91	5.02	5.19	5.37	5.08	5.20	5.38	5.57	
	Amps	17.7	18.0	18.6	19.2	18.9	19.3	19.9	20.6	20.4	20.8	21.5	22.2	21.7	22.1	22.8	23.6	22.9	23.4	24.2	25.0	24.2	24.7	25.5	26.4	
	HI PR	250	269	284	296	280	302	319	332	319	343	362	378	363	391	413	430	409	440	464	484	451	486	513	535	
	LO PR	103	110	120	128	109	116	127	135	113	121	132	140	119	127	138	147	125	133	145	154	129	137	150	160	
	MBh	51.3	52.9	57.2	61.4	50.2	51.6	55.9	60.0	49.0	50.4	54.6	58.6	47.8	49.2	53.2	57.1	45.4	46.7	50.6	54.3	42.0	43.3	46.8	50.3	

IDB = Entering Indoor Dry Bulb Temperature
 High and low pressures are measured at the liquid and suction access fittings.
 Design Subcooling, 12±3 °F @ the liquid access fitting connection AHR1 95 test conditions. Design Superheat 11±3 °F @ the compressor suction access fitting connection.
 Shaded area reflects ACCA (TVA) conditions.
 kW = total system power
 Amps: Unit amps (comp.+ evaporator + condenser fan motors)

IDB		OUTDOOR AMBIENT TEMPERATURE												105												115																			
		65						75						85						95						105						115													
		59	63	67	71	75	79	59	63	67	71	75	79	59	63	67	71	75	79	59	63	67	71	75	79	59	63	67	71	75	79	59	63	67	71	75	79								
ENTERING INDOOR WET BULB TEMPERATURE												105												115																					
1800	MBh	58.3	59.6	63.7	68.1	70.0	58.2	62.2	66.5	71.0	73.0	55.6	56.8	60.7	64.9	54.3	55.4	59.2	63.3	67.1	71.0	73.0	51.5	52.7	56.3	60.1	63.7	67.1	71.0	73.0	51.5	52.7	56.3	60.1	63.7	67.1	71.0	73.0	47.7	48.8	52.1	55.7			
	S/T	0.90	0.84	0.69	0.51	0.93	0.87	0.71	0.53	0.96	0.90	0.73	0.55	1.00	0.92	0.75	0.56	1.00	0.92	0.75	0.56	1.00	0.92	0.75	0.56	1.00	0.96	0.78	0.58	1.00	0.97	0.79	0.59	1.00	0.97	0.79	0.59	1.00	0.97	0.79	0.59	1.00	0.97	0.79	0.59
	ΔT	27	26	22	18	27	26	23	18	27	26	23	18	28	26	23	18	28	26	23	18	28	26	23	18	26	26	22	18	24	24	21	17	24	24	21	17	24	24	21	17	24	24	21	17
	kW	3.94	4.03	4.16	4.30	4.26	4.35	4.50	4.65	4.53	4.64	4.79	4.96	4.78	4.89	5.06	5.23	4.99	5.11	5.28	5.47	5.17	5.29	5.47	5.67	5.17	5.29	5.47	5.67	5.17	5.29	5.47	5.67	5.17	5.29	5.47	5.67	5.17	5.29	5.47	5.67	5.17	5.29	5.47	5.67
	Amps	18.0	18.3	18.9	19.5	19.2	19.7	20.2	20.9	20.7	21.2	21.8	22.6	22.0	22.5	23.2	24.0	23.3	23.8	24.6	25.4	24.6	25.1	25.9	26.8	24.6	25.1	25.9	26.8	24.6	25.1	25.9	26.8	24.6	25.1	25.9	26.8	24.6	25.1	25.9	26.8	24.6	25.1	25.9	26.8
	HI PR	255	274	290	302	286	308	325	339	325	350	370	386	370	399	421	439	417	448	474	494	460	496	523	546	460	496	523	546	460	496	523	546	460	496	523	546	460	496	523	546	460	496	523	546
	LO PR	105	112	122	130	111	118	129	138	116	123	134	143	122	129	141	150	127	136	148	158	132	140	153	163	132	140	153	163	132	140	153	163	132	140	153	163	132	140	153	163	132	140	153	163
	MBh	56.6	57.9	61.8	66.1	55.3	56.5	60.4	64.5	54.0	55.2	58.9	63.0	52.7	53.8	57.5	61.5	50.0	51.1	54.6	58.4	46.3	47.4	50.6	54.1	46.3	47.4	50.6	54.1	46.3	47.4	50.6	54.1	46.3	47.4	50.6	54.1	46.3	47.4	50.6	54.1	46.3	47.4	50.6	54.1
	S/T	0.86	0.80	0.65	0.49	0.89	0.83	0.68	0.51	0.91	0.85	0.70	0.52	0.94	0.88	0.72	0.54	0.98	0.92	0.75	0.56	0.98	0.92	0.75	0.56	0.98	0.92	0.75	0.56	0.98	0.92	0.75	0.56	0.98	0.92	0.75	0.56	0.98	0.92	0.75	0.56	0.98	0.92	0.75	0.56
	ΔT	28	27	23	19	28	27	24	19	28	27	24	19	28	27	24	19	28	27	24	19	28	27	23	19	26	25	22	17	26	25	22	17	26	25	22	17	26	25	22	17	26	25	22	17
kW	3.91	3.99	4.12	4.26	4.22	4.31	4.46	4.61	4.50	4.60	4.75	4.92	4.74	4.85	5.01	5.19	4.95	5.06	5.24	5.42	5.13	5.25	5.43	5.62	5.13	5.25	5.43	5.62	5.13	5.25	5.43	5.62	5.13	5.25	5.43	5.62	5.13	5.25	5.43	5.62	5.13	5.25	5.43	5.62	
Amps	17.8	18.2	18.7	19.3	19.1	19.5	20.1	20.8	20.6	21.0	21.6	22.4	21.8	22.3	23.0	23.8	23.1	23.6	24.4	25.2	24.4	24.9	25.7	26.6	24.4	24.9	25.7	26.6	24.4	24.9	25.7	26.6	24.4	24.9	25.7	26.6	24.4	24.9	25.7	26.6	24.4	24.9	25.7	26.6	
HI PR	252	272	287	299	283	305	322	336	322	347	366	382	367	395	417	435	413	444	469	489	456	491	518	540	456	491	518	540	456	491	518	540	456	491	518	540	456	491	518	540	456	491	518	540	
LO PR	104	111	121	129	110	117	128	136	115	122	133	142	120	128	140	149	126	134	147	156	130	139	152	161	130	139	152	161	130	139	152	161	130	139	152	161	130	139	152	161	130	139	152	161	
MBh	52.3	53.4	57.1	61.0	51.0	52.2	55.7	59.6	49.8	50.9	54.4	58.2	48.6	49.7	53.1	56.7	46.2	47.2	50.4	53.9	42.8	43.7	46.7	49.9	42.8	43.7	46.7	49.9	42.8	43.7	46.7	49.9	42.8	43.7	46.7	49.9	42.8	43.7	46.7	49.9	42.8	43.7	46.7	49.9	
S/T	0.83	0.78	0.63	0.47	0.86	0.80	0.65	0.49	0.88	0.82	0.67	0.50	0.91	0.85	0.69	0.52	0.94	0.88	0.72	0.54	0.95	0.89	0.72	0.54	0.95	0.89	0.72	0.54	0.95	0.89	0.72	0.54	0.95	0.89	0.72	0.54	0.95	0.89	0.72	0.54	0.95	0.89	0.72	0.54	
ΔT	28	27	24	19	29	28	24	19	29	28	24	19	29	28	24	19	29	28	24	19	29	27	24	19	27	26	22	18	27	26	22	18	27	26	22	18	27	26	22	18	27	26	22	18	
kW	3.81	3.89	4.02	4.15	4.11	4.21	4.34	4.49	4.38	4.48	4.63	4.79	4.62	4.72	4.88	5.05	4.82	4.93	5.10	5.28	4.99	5.11	5.28	5.47	4.99	5.11	5.28	5.47	4.99	5.11	5.28	5.47	4.99	5.11	5.28	5.47	4.99	5.11	5.28	5.47	4.99	5.11	5.28	5.47	
Amps	17.4	17.8	18.3	18.9	18.6	19.0	19.6	20.2	20.1	20.5	21.1	21.8	21.3	21.8	22.4	23.2	22.5	23.0	23.7	24.6	23.8	24.3	25.0	25.9	23.8	24.3	25.0	25.9	23.8	24.3	25.0	25.9	23.8	24.3	25.0	25.9	23.8	24.3	25.0	25.9	23.8	24.3	25.0	25.9	
HI PR	245	263	278	290	275	296	312	326	312	336	355	370	356	383	404	422	400	431	455	474	442	476	503	524	442	476	503	524	442	476	503	524	442	476	503	524	442	476	503	524	442	476	503	524	
LO PR	101	108	118	125	107	114	124	132	111	118	129	137	117	124	136	144	122	130	142	151	127	135	147	157	127	135	147	157	127	135	147	157	127	135	147	157	127	135	147	157	127	135	147	157	
MBh	59.3	60.5	63.3	67.6	58.0	59.1	61.9	66.0	56.6	57.7	60.4	64.4	55.2	56.3	58.9	62.9	52.4	53.5	56.0	59.7	48.6	49.5	51.9	55.3	48.6	49.5	51.9	55.3	48.6	49.5	51.9	55.3	48.6	49.5	51.9	55.3	48.6	49.5	51.9	55.3	48.6	49.5	51.9	55.3	
S/T	0.94	0.91	0.82	0.67	0.98	0.94	0.85	0.69	1.00	0.97	0.87	0.71	1.00	1.00	0.90	0.73	1.00	1.00	0.93	0.76	1.00	1.00	0.94	0.76	1.00	1.00	0.94	0.76	1.00	1.00	0.94	0.76	1.00	1.00	0.94	0.76	1.00	1.00	0.94	0.76	1.00	1.00	0.94	0.76	
ΔT	29	28	27	23	29	28	27	23	29	28	27	23	28	29	27	23	27	27	27	23	27	27	25	22	25	25	22	25	25	22	25	25	22	25	25	22	25	25	22	25	25	22	25		
kW	3.97	4.06	4.19	4.33	4.29	4.39	4.53	4.69	4.57	4.68	4.84	5.00	4.82	4.93	5.10	5.28	5.03	5.15	5.33	5.51	5.22	5.34	5.52	5.72	5.22	5.34	5.52	5.72	5.22	5.34	5.52	5.72	5.22	5.34	5.52	5.72	5.22	5.34	5.52	5.72	5.22	5.34	5.52	5.72	
Amps	18.1	18.5	19.0	19.7	19.4	19.8	20.4	21.1	20.9	21.4	22.0	22.8	22.2	22.7	23.4	24.2	23.5	24.0	24.8	25.6	24.8	25.4	26.1	27.1	24.8	25.4	26.1	27.1	24.8	25.4	26.1	27.1	24.8	25.4	26.1	27.1	24.8	25.4	26.1	27.1	24.8	25.4	26.1	27.1	
HI PR	257	277	293	305	289	311	328	342	329	354	373	389	374	403	425	443	421	453	478	499	465	500	528	551	465	500	528	551	465	500	528	551	465	500	528	551	465	500	528	551	465	500	528	551	
LO PR	106	113	124	132	112	120	131	139	117	124	136	145	123	131	143	152	129	137	149	159	133	142	155	165	133	142	155	165	133	142	155	165	133	142	155	165	133	142	155	165	133	142	155	165	
MBh	57.6	58.7	61.5	65.6	56.3	57.4	60.1	64.1	54.9	56.0	58.6	62.6	53.6	54.6	57.2	61.0	50.9	51.9	54.4	58.0	47.2	48.1	50.3	53.7	47.2	48.1	50.3	53.7	47.2	48.1	50.3	53.7	47.2	48.1	50.3	53.7	47.2	48.1	50.3	53.7	47.2	48.1	50.3	53.7	
S/T	0.90	0.87	0.78	0.63	0.93	0.90	0.81	0.66	0.96	0.92	0.83	0.67	0.99	0.95	0.86	0.70	1.00	0.99	0.89	0.72	1.00	1.00	0.90	0.73	1.00	1.00	0.90	0.73	1.00	1.00	0.90	0.73	1.00	1.00	0.90	0.73	1.00	1.00	0.90	0.73	1.00	1.00	0.90	0.73	
ΔT	30	29	28	24	30	30	28	24	30	30	28	24	30	30	28	24	29	29	28	24	27	28	26	22	27	28	26																		

MODEL	SPEED*	VOLTS	TYPE	E.S.P. (IN. OF H ₂ O)							
				0.1	0.2	0.3	0.4	0.5	0.6	0.7	0.8
GPC15 24H41A*	T1	230	CFM Watts	922 74	873 85	823 96	774 107	724 118	675 129	626 140	576 151
	T2,T3	230	CFM Watts	922 74	873 85	823 96	774 107	724 118	675 129	626 140	576 151
	T4, T5	230	CFM Watts	1231 168	1179 180	1127 193	1074 205	1022 218	969 230	917 243	865 255
GPC15 30H41A*	T1	230	CFM Watts	1048 97	993 109	939 122	884 134	829 147	775 159	720 172	666 184
	T2,T3	230	CFM Watts	1123 123	1068 136	1014 148	959 161	905 173	850 186	796 198	741 211
	T4, T5	230	CFM Watts	1462 241	1409 253	1357 266	1305 278	1252 291	1200 303	1147 315	1095 328
GPC15 36H41B*	T1	230	CFM Watts	1151 132	1097 144	1042 156	988 169	933 181	879 194	824 206	770 219
	T2,T3	230	CFM Watts	1261 131	1215 144	1169 157	1123 169	1076 182	1030 194	984 207	937 220
	T4, T5	230	CFM Watts	1577 277	1525 290	1472 302	1420 314	1367 327	1315 339	1263 352	1210 364
GPC15 42H41A*	T1	230	CFM Watts	1181 146	1146 158	1112 174	1062 182	1022 196	977 208	937 218	891 227
	T2/T3	230	CFM Watts	1410 222	1366 236	1328 250	1286 260	1248 273	1195 285	1155 296	1115 305
	T4/T5	230	CFM Watts	1637 331	1605 348	1561 361	1527 374	1484 385	1436 392	1390 407	1345 417
GPC15 48H41A*	T1	230	CFM Watts	1337 179	1297 190	1218 203	1155 210	1118 225	1088 243	1022 249	989 268
	T2/T3	230	CFM Watts	1711 330	1640 341	1605 358	1537 370	1496 377	1441 394	1397 408	1347 418
	T4/T5	230	CFM Watts	2002 498	1935 521	1885 516	1827 534	1767 551	1732 567	1669 571	1618 574
GPC15 60H41B*	T1	230	CFM Watts	1337 179	1297 190	1218 203	1155 210	1118 225	1088 243	1022 249	989 268
	T2,T3	230	CFM Watts	1694 296	1646 303	1598 311	1549 319	1501 327	1453 334	1405 342	1357 350
	T4, T5	230	CFM Watts	2002 498	1935 521	1885 516	1827 534	1767 551	1732 567	1669 571	1618 574

* Speed set at T2 at the factory.

MODEL AND HEAT KIT USAGE	CIRCUIT #1		CIRCUIT #2		SINGLE-POINT KIT		ACTUAL kW / BTU@ 240V
	MCA ¹	MOP ²	MCA ¹	MOP ²	MCA ¹	MOP ²	
GPC1524H41A*	3.8	---	---	---	--	--	---
HKP-05C*	21 / 25	25 / 25	---	---	30	30	4.75 / 16,200
HKR-08C*	32 / 36	35 / 40	---	---	41	45	7 / 23,800
HKP-10C*	43 / 49	45 / 50	---	---	54	60	9.5 / 32,400
GPC1530H41A*	3.8	---	---	---	--	--	---
HKP-05C*	21 / 25	25 / 25	---	---	30	35	4.75 / 16,200
HKR-08C*	32 / 36	35 / 40	---	---	41	45	7 / 23,800
HKP-10C*	43 / 49	45 / 50	---	---	54	60	9.5 / 32,400
HKP-15C*	43 / 49	45 / 50	21 / 25	25 / 25	79	80	14.25 / 48,600
GPC1536H41B*	3.8	---	---	---	--	--	---
HKP-05C*	21 / 25	25 / 25	---	---	30	40	4.75 / 16,200
HKR-08C*	32 / 36	35 / 40	---	---	41	45	7 / 23,800
HKP-10C*	43 / 49	45 / 50	---	---	54	60	9.5 / 32,400
HKP-15C*	43 / 49	45 / 50	21 / 25	25 / 25	79	80	14.25 / 48,600
GPC1542H41A*	3.8	---	---	---	--	--	---
HKP-05C*	21 / 25	25 / 25	---	---	30	45	4.75 / 16,200
HKR-08C*	32 / 36	35 / 40	---	---	41	45	7 / 23,800
HKP-10C*	43 / 49	45 / 50	---	---	54	60	9.5 / 32,400
HKP-15C*	43 / 49	45 / 50	21 / 25	25 / 25	79	80	14.25 / 48,600
HKP-20C	43 / 49	45 / 50	43 / 49	45 / 50	104	110	19.0 / 64,800
GPC1548H41A*	5.4	---	---	---	--	--	---
HKP-05C*	21 / 25	25 / 25	---	---	32	50	4.75 / 16,200
HKR-08C*	32 / 36	35 / 40	---	---	43	50	7 / 23,800
HKP-10C*	43 / 49	45 / 50	---	---	56	60	9.5 / 32,400
HKP-15C*	43 / 49	45 / 50	21 / 25	25 / 25	81	90	14.25 / 48,600
HKP-20C	43 / 49	45 / 50	43 / 49	45 / 50	106	110	19.0 / 64,800
GPC1560H41B*	5.4	---	---	---	--	--	---
HKP-05C*	21 / 25	25 / 25	---	---	41	60	4.75 / 16,200
HKR-08C*	32 / 36	35 / 40	---	---	43	60	7 / 23,800
HKP-10C*	43 / 49	45 / 50	---	---	56	60	9.5 / 32,400
HKP-15C*	43 / 49	45 / 50	21 / 25	25 / 25	81	90	14.25 / 48,600
HKP-20C	43 / 49	45 / 50	43 / 49	45 / 50	106	110	19.0 / 64,800

¹ Minimum Circuit Ampacity @ 208 / 240 V

² Maximum Overcurrent Protection Device @ 208 / 240 V

* Revision level that may or may not be designated

C Circuit breaker option

NOTE: HKP-15C* and HKP-20C* replace HKR-15C and HKR-20C respectively to meet new UL1995 requirements.

SINGLE-POINT KIT ACCESSORY KITS

Select the single-point kit accessory based on the unit model.

MODEL	SINGLE-POINT KIT
GPC1524***41**	SPK-30
GPC1530***41**	SPK-35
GPC1536***41**	SPK-40
GPC1542***41**	SPK-45
GPC1548***41**	SPK-50
GPC1560***41**	SPK-60

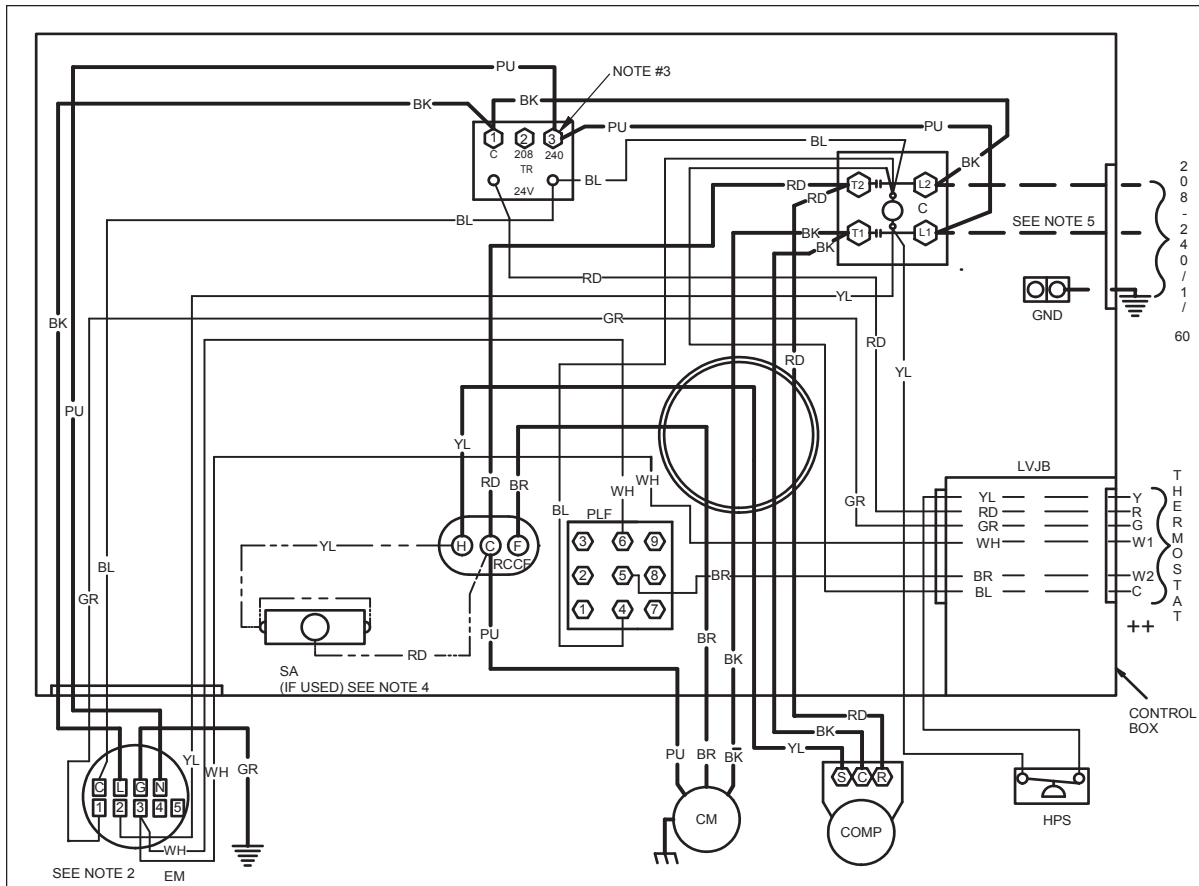

High Voltage: Disconnect all power before servicing or installing this unit. Multiple power sources may be present. Failure to do so may cause property damage, personal injury, or death.

WARNING

Wiring is subject to change. Always refer to the wiring diagram or the unit for the most up-to-date wiring.

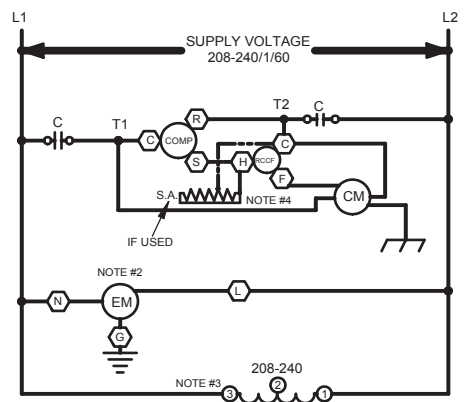

COMPONENT LEGEND

- BR BLOWER INTERLOCK RELAY
- C CONTACTOR
- CH CRACKCASE HEATER
- CM CONDENSER MOTOR
- COMP COMPRESSOR
- EBTDR ELECTRONIC BLOWER TIME DELAY RELAY
- EM EVAPORATOR MOTOR
- FC FAN CAPACITOR
- GND EQUIPMENT GROUND
- LVJB LOW VOLTAGE JUNCTION BOX
- PLF FEMALE PLUG / CONNECTOR
- RCCF RUN CAPACITOR FOR COMPRESSOR AND FAN
- SA START ASSIST
- TR TRANSFORMER
- HPS HIGH PRESSURE SWITCH

- FACTORY WIRING**
- LINE VOLTAGE
 - LOW VOLTAGE
 - OPTIONAL HIGH VOLTAGE

- FIELD WIRING**
- HIGH VOLTAGE
 - - - LOW VOLTAGE

- WIRE CODE**
- BK BLACK
 - BL BLUE
 - BR BROWN
 - GR GREEN
 - OR ORANGE
 - PU PURPLE
 - RD RED
 - WH WHITE
 - YL YELLOW

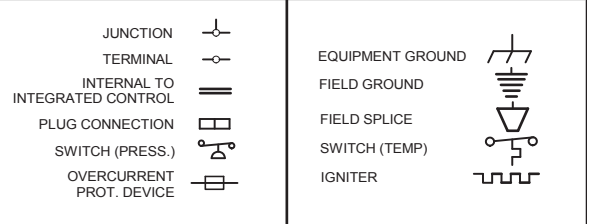

NOTES:

1. REPLACEMENT WIRE MUST BE SAME SIZE AND TYPE INSULATION AS ORIGINAL (AT LEAST 105°C) USE COPPER CONDUCTOR ONLY.
 2. TO CHANGE EVAPORATOR MOTOR SPEED REPLACE LEAD ON EBTDR "COM" WITH LEAD ON EBTDR "M1" OR "M2"
 3. FOR 208 VOLT TRANSFORMER OPERATION MOVE PURPLE WIRES FROM TERMINAL 3 TO TERMINAL 2 ON TRANSFORMER.
 4. START ASSIST FACTOR EQUIPPED WHEN REQUIRED
 5. USE COPPER CONDUCTORS ONLY
- ++ USE N.E.C. CLASS 2 WIRE

SEE UNIT RATING PLATE FOR TYPE AND SIZE OF OVER CURRENT PROTECTION



208-240/1/60 0140G00871-C

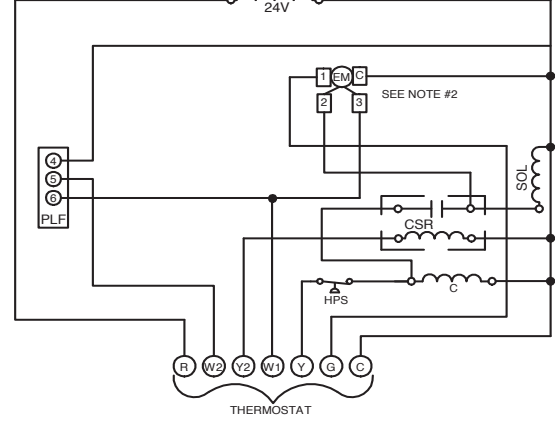
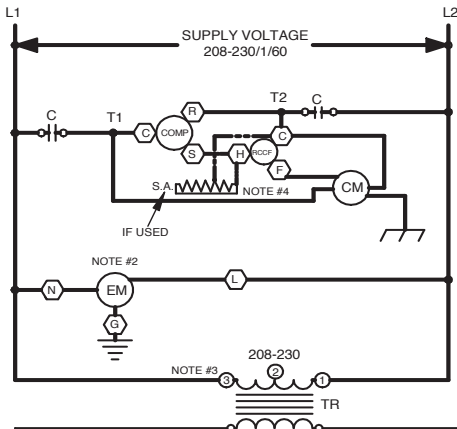
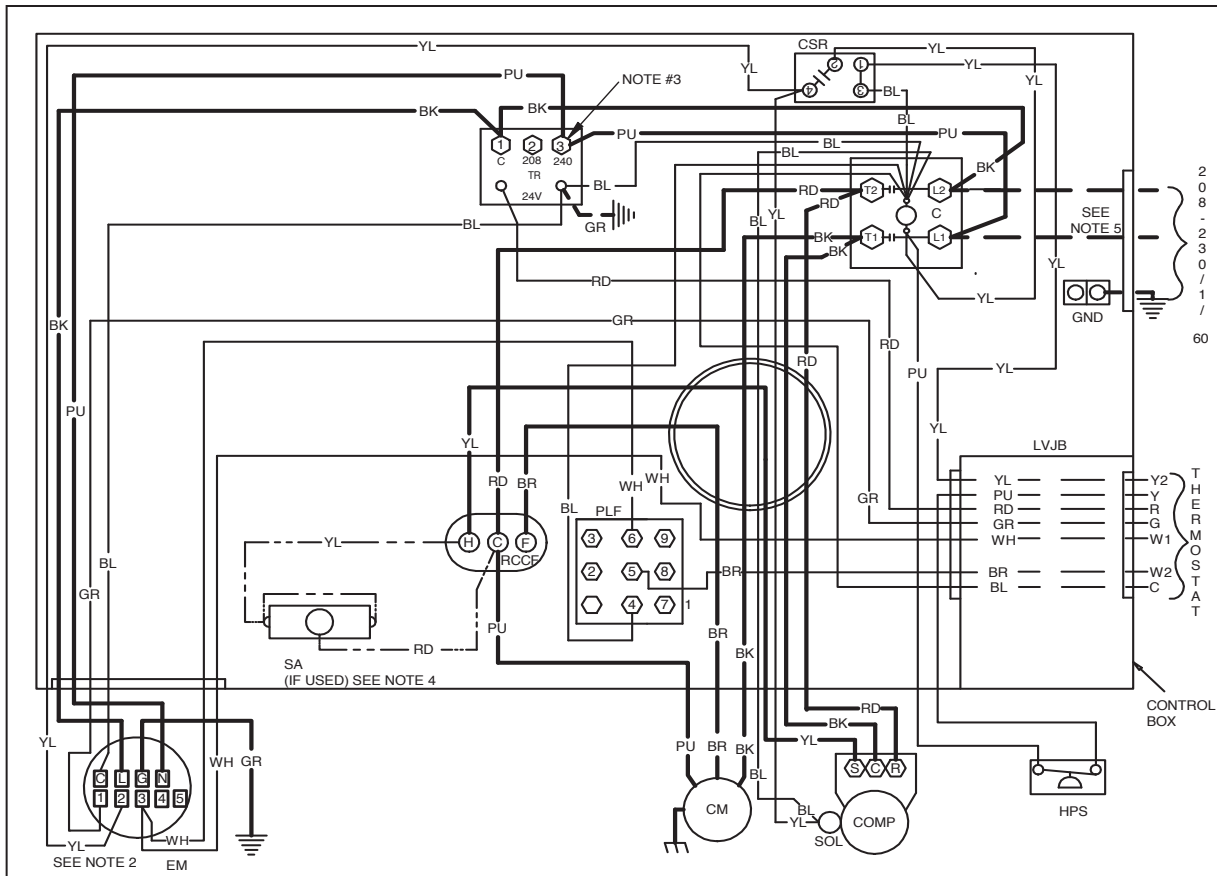

COMPONENT LEGEND		FACTORY WIRING	
C	CONTACTOR	—	LINE VOLTAGE
CM	CONDENSER MOTOR	—	LOW VOLTAGE
COMP	COMPRESSOR	—	OPTIONAL HIGH VOLTAGE
EM	EVAPORATOR MOTOR	---	FIELD WIRING
GND	EQUIPMENT GROUND	---	HIGH VOLTAGE
LVJB	LOW VOLTAGE JUNCTION BOX	---	LOW VOLTAGE
PLF	FEMALE PLUG / CONNECTOR		
RCCF	RUN CAPACITOR FOR COMPRESSOR AND FAN		
SA	START ASSIST		
TR	TRANSFORMER		
HPS	HIGH PRESSURE SWITCH		
CSR	COMPRESSOR SOLENOID RELAY		
SOL	HI STAGE SOLENOID		
		WIRE CODE	
		BK	BLACK
		BL	BLUE
		BR	BROWN
		GR	GREEN
		OR	ORANGE
		PU	PURPLE
		RD	RED
		WH	WHITE
		YL	YELLOW

JUNCTION		EQUIPMENT GROUND	
TERMINAL		FIELD GROUND	
INTERNAL TO INTEGRATED CONTROL		FIELD SPLICE	
PLUG CONNECTION		SWITCH (TEMP)	
SWITCH (PRESS.)		IGNITER	
OVERCURRENT PROT. DEVICE			

- NOTES:**
- REPLACEMENT WIRE MUST BE SAME SIZE AND TYPE INSULATION AS ORIGINAL (AT LEAST 105°C) USE COPPER CONDUCTOR ONLY.
 - TO CHANGE EVAPORATOR MOTOR SPEED MOVE YELLOW AND WHITE LEADS FROM EM "2" AND "3" TO "4" AND "5". IF BOTH LEADS ARE ENERGIZED, THE HIGHER SPEED SETTING IS USED.
 - FOR 208 VOLT TRANSFORMER OPERATION MOVE PURPLE WIRES FROM TERMINAL 3 TO TERMINAL 2 ON TRANSFORMER.
 - START ASSIST FACTOR EQUIPPED WHEN REQUIRED
 - USE COPPER CONDUCTORS ONLY
- ++ USE N.E.C. CLASS 2 WIRE

SEE UNIT RATING PLATE FOR TYPE AND SIZE OF OVER CURRENT PROTECTION



208-230/1/60 0140G03702-A

High Voltage: Disconnect all power before servicing or installing this unit. Multiple power sources may be present. Failure to do so may cause property damage, personal injury, or death.

WARNING

Wiring is subject to change. Always refer to the wiring diagram or the unit for the most up-to-date wiring.

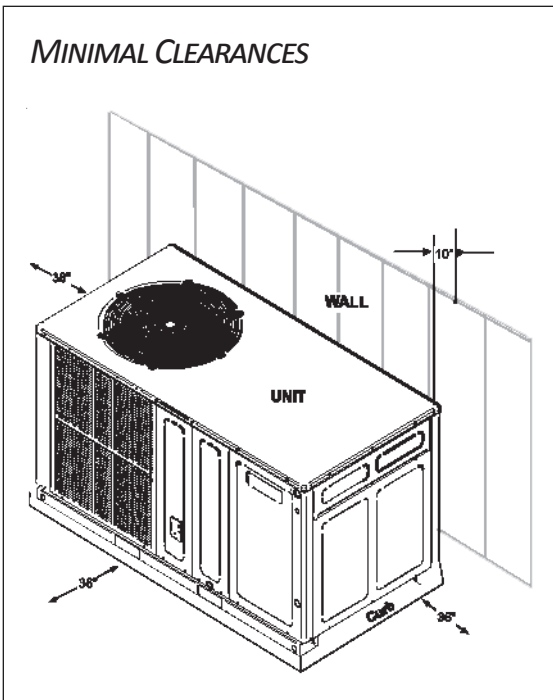
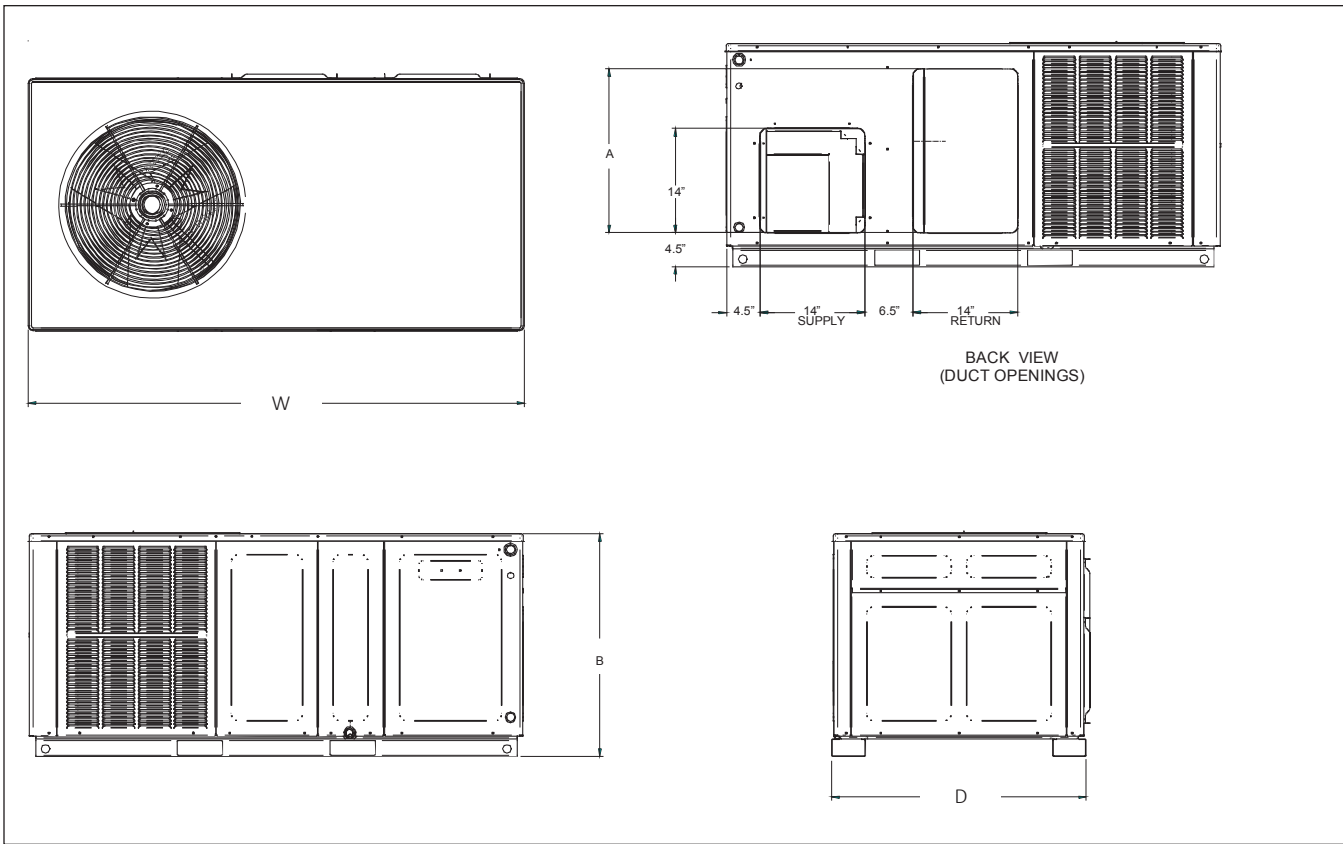

MODEL	DIMENSIONS					CHASSIS SIZE
	W"	D"	H"	A"	B"	
GPC1524H41A*	66	33	30½	22	30	Small
GPC1530H41A*	66	33	30½	22	30	Small
GPC1536H41B*	66	33	30½	22	30	Small
GPC1542H41A*	66	33	30½	22	30	Small
GPC1548H41A*	66	33	35½	24	35	Medium
GPC1560H41B*	66	33	35½	24	35	Medium