

TEMPCONTROL Repair Parts

Model No. Inlets Outlet

5-100	1/2	1/2
5-101	1/2	1/2
5-101P	1/2	1/2
5-102	1/2	1/2
5-102P	1/2	1/2

Suffix HC High Capacity
Model specify
when ordering
cartridge

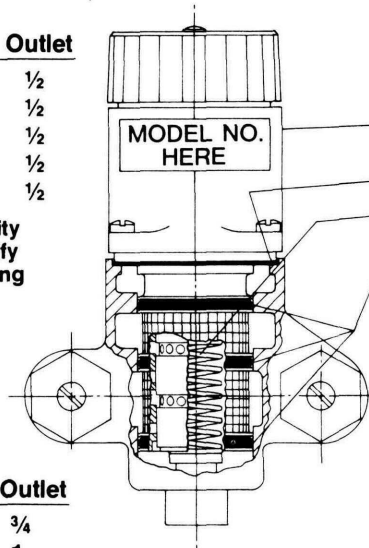

- INSERT PROPER MODEL NUMBER IN PARENTHESIS
- CARTRIDGE UNIT 5-() NW CARTRIDGE
 - TT-11-100 CASING GASKET
 - TT-16-100 SPRING with SPRING SADDLE
 - TT-15-100 SLEEVE O-RINGS (3 REQ'D.)
 - CSE-35 CHECK SPINDLE
 - CSE-29 O-RING
 - CSE-31 WASHER
 - CSE-26 CAP
 - CSE-34 SPRING
 - CSE-33 CHECK
 - CE-30 GASKET (2 PAIR REQ'D.)
 - CSE-32 CHECK WASHER
 - CSE-25 STOP BODY with INTEGRAL SEAT

Model No. Inlets Outlet

5-200	3/4	3/4
5-400	3/4	1
5-500	1	1 1/4
5-700	1 1/4	1 1/2

5-200-1 } lower capacity units
5-400-1 } GLAND NUT DISTINGUISHES VALVE PRIOR TO 1988

- *TT-22-() STOP SPINDLE
- TT-19-() GLAND NUT & PACKING
- *TT-20-() CAP
- TT-21-() CAP GASKET
- TT-24-() CHECK SPINDLE & SPRING

INSERT PROPER MODEL NUMBER IN PARENTHESIS

STOP PARTS BEFORE 1988

*NO LONGER AVAILABLE, ORDER TT-50AN-() CONSISTING OF TT-22N-(), TT-20N-(), TT-47N-(), TT-21-(), TT-24N-() & TT-17N-()

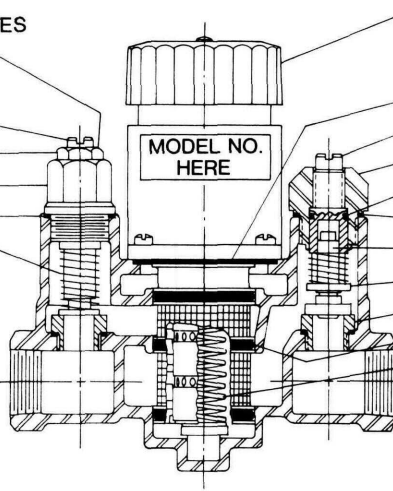

- CARTRIDGE UNIT 5-() NW CARTRIDGE
- TT-11-() CASING GASKET
 - *TT-22N-() STOP SPINDLE
 - *TT-20N-() CAP
 - *TT-47N-() STOP SPINDLE O-RING
 - TT-21-() CAP GASKET
 - *TT-24N-() CHECK SPINDLE & SPRING
 - *TT-17N-() CHECK SPRING RETAINER
 - TT-26-() CHECK SEAT
 - TT-15-() SLEEVE O-RINGS (3 REQ'D.)
 - TT-16-() SPRING with SPRING SADDLE

INSERT PROPER MODEL NUMBER IN PARENTHESIS

*STOP PARTS 1988 TO DATE

Model No. Inlets Outlet

5-900	1 1/2	1 1/2
5-1000	1 1/2	2

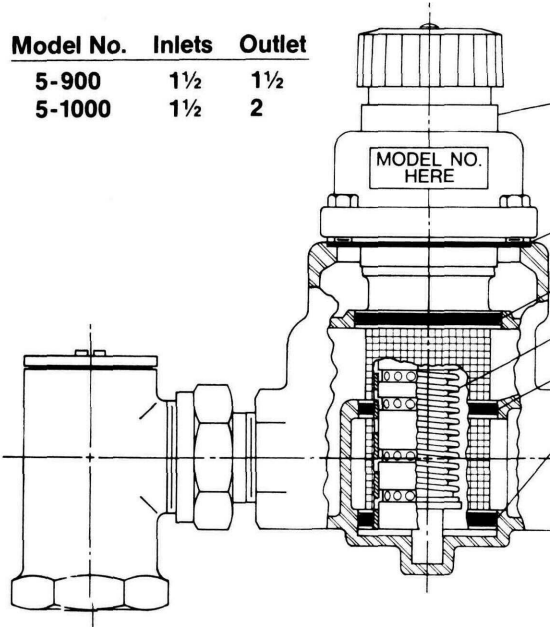

- CARTRIDGE UNIT 5-() NW CARTRIDGE
- TT-11-() CASING GASKET
 - TT-15L-() SLEEVE LARGE O-RING
 - TT-16-() DOUBLE SPRING with SPRING SADDLE
 - TT-15S-() SLEEVE SMALL O-RINGS (2 REQ'D.)
 - TT-22-() STOP SPINDLE
 - TT-19-() GLAND NUT & PACKING
 - TT-20-() CAP
 - TT-21-() CAP GASKET
 - TT-27-() CHECK STOP BODY with INTEGRAL SEAT
 - TT-24-() CHECK SPINDLE & SPRING

INSERT PROPER MODEL NUMBER IN PARENTHESIS

TEMPCONTROL®

Thermostatic Water Controller

INSTALLATION, OPERATION AND SERVICE INSTRUCTIONS

All TempControl Installations must have a thermometer and shut off valve in the tempered water outlet (as shown in diagrams) for proper trouble shooting service.

IMPORTANT

When these installation, operation and service instructions are not followed, TempControl service life will be greatly impaired.

SIZING AND TECHNICAL ASSISTANCE

For assistance and technical support in sizing and selection of the proper TempControl valve or system, consult the Symmons TempSize™ computer sizing software, your local representative or Symmons Customer Service Department at **1-800-SYMMONS**.

TEMPCONTROL LOCATION

An underlying premise of thermostatic water controller installations is an acknowledgement that thermostatic mixing valves will not operate properly when the hot and cold supplies serving such valves are subjected to pressure disturbances when flowing less than full capacity. In a correctly designed mechanical room, the supply pressures are stable and not subject to pressure disturbances. As a result, when a TempControl valve is indicated as being located in the mechanical room, a Hi-Low system will not be recommended.

When the valve's location is indicated as being outside of the mechanical room, it is assumed that there is a potential for pressure fluctuations in the hot and cold supply lines servicing a TempControl valve and a Hi-Low system will automatically be recommended.

Note: If the system is designed so that the TempControl valve is not subjected to hot and cold supply pressure disturbances, even though it is located outside the mechanical room, a single TempControl valve will operate properly.

INSTALLATION AND OPERATION

All piping should be thoroughly flushed before TempControl is installed. The TempControl can be installed in any position as long as Hot Water is connected to "H" port and Cold Water is connected to "C" port. Close service stops on TempControl, remove cartridge, (see procedure on bottom of page). Turn on water supply, open stops wide to thoroughly flush piping before putting valve in service. TempControl is set at factory to deliver approximately 120 F. With several fittings flowing water, turn knob to obtain desired setting and lock setscrew. To change high limit, turn knob to maximum hot, remove dial and turn slotted screw counter-clockwise for higher setting, clockwise for lower setting. **Valve must be flowing when setting temperature.** These setting instructions are on valve label. Thermostatic water controllers should be sized according to the flow capacity required from the valve, **NOT** the pipe size supplied to the valve. For assistance and technical support in sizing and selection of the proper TEMPCONTROL Thermostatic Water Controller, consult the Symmons TEMPSIZE™ computer sizing software, your local representative or Symmons Customer Service Department at 1-800-SYMMONS.

MAINTENANCE

The cartridge unit contains the entire valve control mechanism. For non-interrupted service, keep a spare cartridge on hand.

TempControl valve control mechanism must be kept clean and free from deposits and any foreign matter build-up that will be present in many water systems. **Inspect within 30 days of initial installation or operation.** If inspection determines that your water system causes deposits and foreign matter build-up monthly, then valve should be cleaned monthly as follows: Remove cartridge and soak in any acceptable de-liming agent (or regular household vinegar). Wash off deposits, be sure piston is moving freely in its sleeve, and replace cartridge. Clean more frequently if your system so demands (Do not completely remove piston from cartridge).

The Check Valves in the TempControl are highly important factors in its proper operation. If chips, dirt or other foreign materials lodge on the Seats and prevent the checks from fully seating, there may be a by-pass of water into the opposing line, and the TempControl will not operate to its set delivery temperature. A by-pass may be detected by feeling the supply line while the TempControl is not operating. If, for example, the cold line feels hot, the cold water check is not seating properly. It should be removed and the check and its seat cleaned.

Constant by-passing of hot water will ruin the temperature control mechanism by keeping it constantly expanded.

The valve will operate most efficiently at controlling a set temperature, when flowing at its maximum capacity for any given supply pressure. For example, if supply pressure is 45 psi, the maximum flow rate will be 10 GPM. If it is desired to have a lower flow rate with this 45 psi supply pressure, reduce volume flow as follows:

Shut off screwdriver supply stops and open volume control shut-off valve wide...determine maximum desired flow rate and open screwdriver stops (an equal amount of hot and cold) to obtain the desired flow rate. Now use volume control shut-off for future operation.

When valve is used at low temperatures (normally below 90 F), always be sure cold water supply is 10 F lower than set temperature for efficient operation. In some cases it may be necessary to supply chilled water to valve.

SEASONAL USE

When a TempControl is used seasonally (schools, campgrounds, golf clubs, etc.), the cartridge must be removed and thoroughly drained of all water. The check stops should also be removed to drain all water from the supply lines and valve body (See "cartridge removal and replacement"). This will prohibit damage caused by freezing water.

CARTRIDGE REMOVAL AND REPLACEMENT

Before removing a used cartridge for cleaning, **have new casing gasket and sleeve o-rings on hand.**

Shut off supplies at stop checks by turning clockwise.

Remove 4 bolts on cartridge bolt flange.

With 2 large bladed screwdrivers, pry evenly on two opposite sides of bolt flange until cartridge is free to be removed by hand. Pull out cartridge with a twisting and turning action, always keeping cartridge on center line.

Leave compensating spring in position at bottom center of valve body.

Clean cartridge as described in maintenance instructions above.

Replace sleeve O-rings and grease same.

With a twisting and pushing action, replace cartridge in valve body until bolt flange is firmly against housing gasket.

While holding cartridge in place, replace bolts and tighten.

Caution: Do not attempt to pull cartridge into position with bolts—it will damage the valve control mechanism.

Open stops and adjust temperature.

The logo for Symmons, featuring the brand name in a stylized, cursive script font.