



# ETF24096TDJ

## 24V DC 96W Dimmable Electronic Transformer in J-box

Project: \_\_\_\_\_

Location: \_\_\_\_\_

Qty: \_\_\_\_\_

Notes: \_\_\_\_\_

### DESCRIPTION

24V DC 96W Class 2 Mini Electronic Transformer in Junction Box  
 Constant Voltage Triac / ELV / MLV Dimmable

### FEATURES & BENEFITS

- Compact - fits in limited spaces
- Wiring Compartments for line and low voltage
- UL Listed, Class 2, Class P, Type HL
- Short Circuit & Over Load Protection
- Hiccup mode, recovers automatically after fault condition is removed

**DIMENSIONS** 5" x 3 1/4" x 1 5/8"

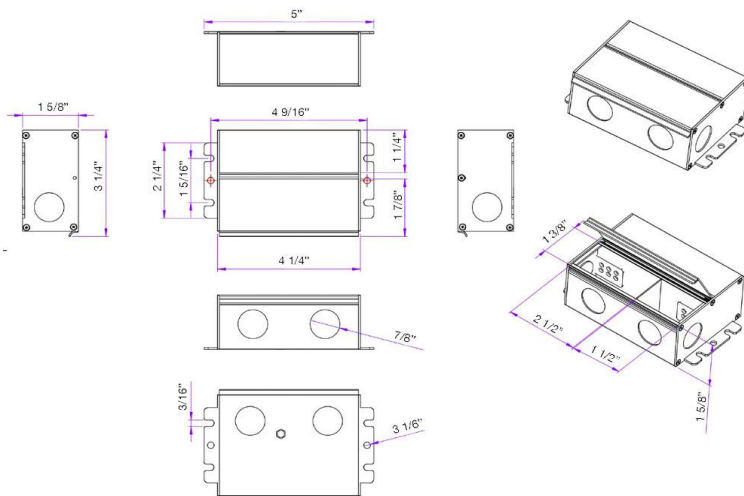

SPECIFICATION	
Applications	LED Tape, 24 V DC Ceiling Fixtures
Power	96 W
Input V / Hz	120 V AC / 47-63 Hz
Output V / A	24 V DC ± 1.5 V / 4 A
Type	Constant Voltage Electronic Transformer
Dimmability	Triac / ELV / MLV
Min / Max Load	20% to 80%
THD @ 120V	without dimmer: resistive load 3%, LED load 33%
with 80% load	with dimmer: resistive load 29%, LED load 48%
Efficiency	88%
Power Factor	0.94
PWM Frequency	120 Hz
Protection	Short circuit & Overload auto recovery
Approved Location	Dry and Damp Locations
Ambient Conditions	-40°F (-40°C) to +140°F (+60°C), 20-95% RH
Warranty	3 Year
Certification	c UL us Listed, Class 2, Type HL, FCC Title 47 Class B

**ORDERING GUIDE** ETF24096TDJ

### WARNING:

Do not exceed ambient temperature range from -40°F (-40°C) to +140°F (+60°C). Please mount in a shaded area or when mounted indoors install in a well-ventilated area. Load to maximum 80%. Failure to follow these instructions could lead to overheating, short life and void the warranty.

Load vs Ambient Temp Curve

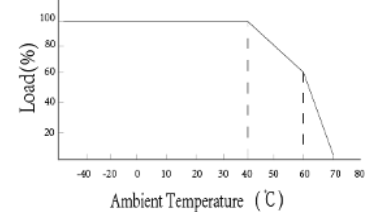

### WIRING DIAGRAM



**Lotus LED Lights USA**  
 250 H Street # 301, Blaine WA 98230 tel 360-200-5500  
 Hainesport NJ & Ferndale WA

[www.LotusLEDLights.com](http://www.LotusLEDLights.com)  
 mailing addresses  
 warehouses

**Lotus LED Lights CANADA**  
 1080 Cliveden Ave # 6, Delta BC V3M 6G6 tel 604-538-3090  
 Delta BC & Mississauga ON