

Hydraulic Separators



Stainless Steel Hydraulic Separators with Flange Connections



LLH400M

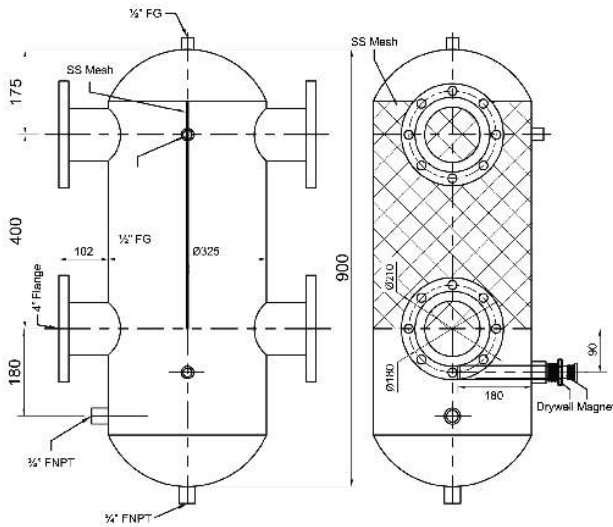

- M50 grade neodymium rod magnets
- 10,000 gauss holding force, temperature rated to 90C
- Operation temperature range, 0-100°C/132-270°F
- 1/2" Air vent, Drain, Included



LLH600M

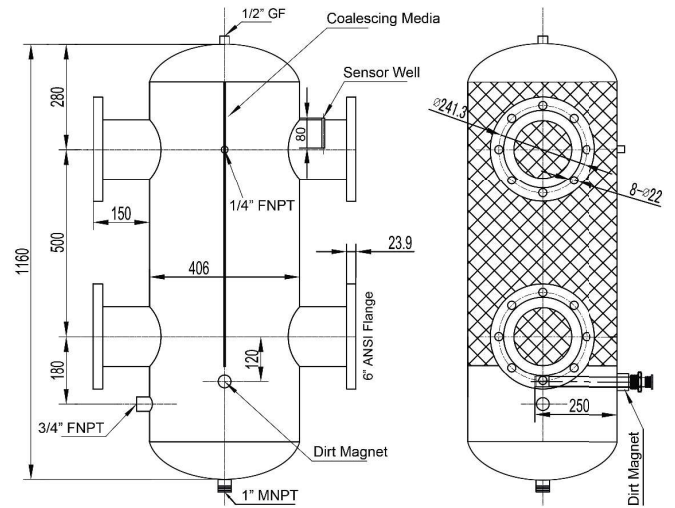

- Coalescing Media: Stainless Steel
- Connection for makeup water
- Max. Operational Pressure, 10 bar/150 PSI
- Pressure Gauge, Included

Model Number	Flange	Flow	Drain	Makup Water	Magnet Size	Weight
LLH400M	4" DN100 ANSI B16.5 Class 150	260 GPM	3/4" FNPT	3/4" FNPT	25Ø X 190 mm	100 Lbs
LLH600M	6" DN150 ANSI B16.5 Class 150	485 GPM	1" MNPT	3/4" FNPT	25Ø X 190 mm	145 Lbs

Hydraulic Separators



Stainless Steel Hydraulic Separators with Flange Connections



LLH250M



LLH300M

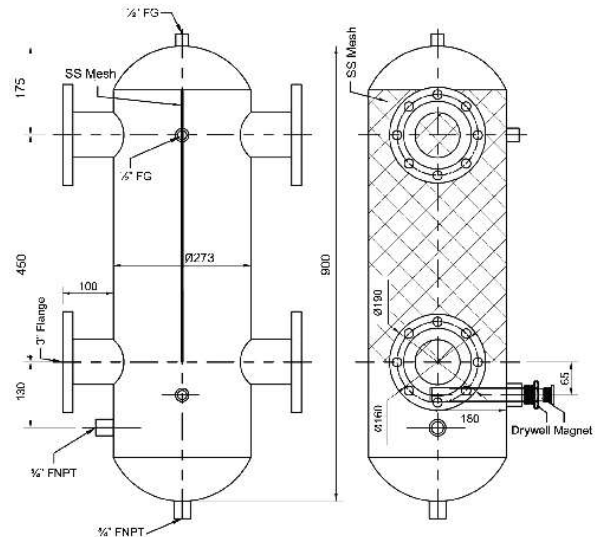
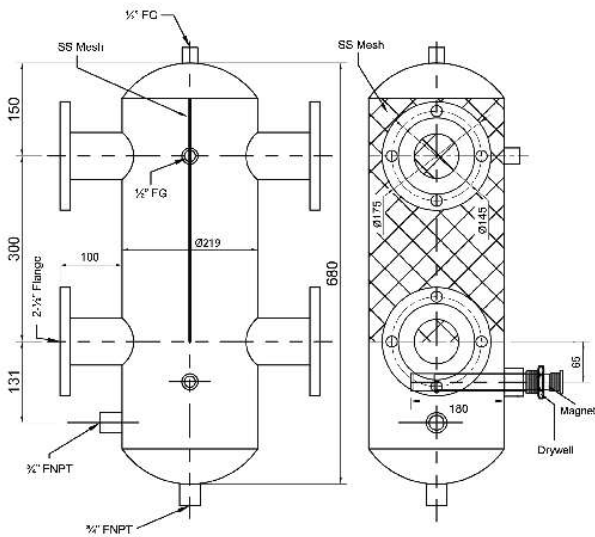

- M50 grade neodymium rod magnets
- 10,000 gauss holding force, temperature rated to 90C
- Operation temperature range, 0-100°C/132-270°F
- 1/2" Air vent, Drain, Included

- Coalescing Media: Stainless Steel
- Connection for makeup water
- Max. Operational Pressure, 10 bar/150 PSI
- Pressure Gauge, Included

Model Number	Flange	Flow	Drain	Makup Water	Magnet Size	Weight
LLH250M	2-1/2" DN65 ANSI B16.5 Class 150	90 GPM	1/2" FNPT	1/2" FNPT	25Ø X 190 mm	50 Lbs
LLH300M	3" DN80 ANSI B16.5 Class 150	145 GPM	3/4" FNPT	3/4" FNPT	25Ø X 190 mm	75 Lbs