

## **TECHNICAL & SERVICE MANUAL V1.1**

### **—AIR HANDLER CONDITIONERS**

#### **INDOOR UNIT**

##### **Models:**

**AUH-24UX3SDH2**

**AUH-36UX3SDH2**

**AUH-48UX3SEH2**

**AUH-60UX3SEH2**

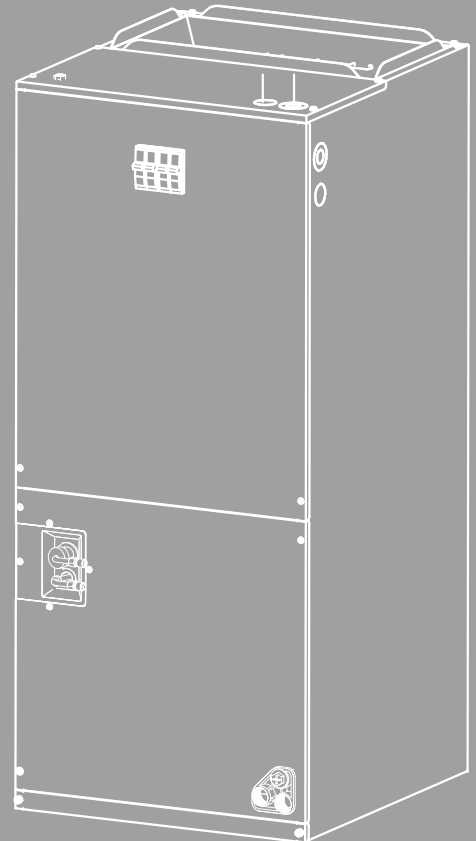

# SAFETY SUMMARY

## IMPORTANT NOTICE

- We adopt a strategy of constant product performance and design enhancements. Therefore, the option to change specifications without prior notification is reserved.
- We cannot anticipate every possible circumstance that might involve a potential hazard.
- This air conditioner is designed for standard air conditioning only. Do not use this air conditioner for other purposes such as drying clothes, refrigerating foods or for any other cooling or heating process. Do not let the air-out face animals or plants, it might have an adverse effect on them.
- The installation and system specialist must ensure leakage safety in accordance with any applicable local laws or standards.
- Important symbols words (DANGER, WARNING and CAUTION) are used to identify levels of hazard seriousness. Definitions for identifying hazard levels are provided below with their respective signal words.

**▲ DANGER**

: Immediate hazards which WILL result in severe personal injury or death.

**▲ WARNING**

: Hazards or unsafe practices which COULD result in severe personal injury or death.

**▲ CAUTION**

: Hazards or unsafe practices which COULD result in minor personal injury or product or property damage.

**NOTE**

: Useful information for operation and/or maintenance.

- Installation should be performed by the dealer or other professional personnel. Improper installation may cause water leakage, electrical shock, or fire.

**▲ DANGER**

- Do not perform installation work, refrigerant piping work, drain piping and electrical wiring connection without referring to our installation manual. If the instructions are not followed, it may result in water leakage, electric shock or fire.
- Use refrigerant R410A in the refrigerant cycle.
- Do not pour water into the indoor or outdoor unit. These products are equipped with electrical parts. If poured, it will cause a serious electrical shock.
- Do not open the service cover or access panel for the indoor or outdoor units without turning OFF the main power supply.
- Do not touch or adjust safety devices inside the indoor or outdoor units. If these devices are touched or readjusted, it may cause a serious injury.
- Refrigerant leakage can cause difficulty in breathing due to insufficient air. Turn OFF the main switch, extinguish any naked flames and contact your service contractor, if refrigerant leakage occurs.
- Do Not perform air-tight test. Do not charge oxygen, acetylene or other flammable and poisonous gas into the refrigerant cycle when performing a leakage test or an air-tight test. These types of gas are extremely dangerous and can cause an explosion. It is recommended that nitrogen be used for this test.
- The installer and system specialist must ensure leakage safety in accordance with any applicable local laws or standards.
- Use an ELB (Electric Leakage Breaker). In the event of a fault, there is danger of an electric shock or a fire if it is not used.

**▲ WARNING**

- Do not use any sprays such as insecticide, lacquer, hair spray or other flammable gas within approximately one (1) meter from the system.

- If a circuit breaker or fuse frequently trips, stop the system and contact your service contractor.
- Check that the ground wire is securely connected. If the unit is not correctly grounded, it will lead to electric shock. Do not connect the ground wiring to gas piping, water piping, lightning conductor or ground wiring for telephone.
- Before performing any brazing work, check to ensure that there is no flammable material around when using refrigerant. Be sure to wear leather gloves to prevent cold injuries.
- If not protected, Rodents and other small animals may gnaw at unprotected parts, which may lead to fire.
- Install the cables securely. External forces on the terminals could lead to a fire.
- Install the air conditioner on a solid base that can support the unit weight. An inadequate base or incomplete installation may cause injury in the event the unit falls off the base. Incomplete connections or clamping may cause terminal overheating or fire.
- Make sure that the outdoor unit is not covered with snow or ice, before operation.

**⚠ CAUTION**

- Do not step or put any material on the product.
- Do not put any foreign material on the unit or inside the unit.

**NOTE**

- It is recommended that the room be ventilated every 3 to 4 hours.
- The air conditioner may not work properly under the following circumstances.  
The power transformer provides the same power with the air conditioner. The electrical equipment is too close to the power supply of the air conditioner. With the sharp change of power consumption and switching action, the power supply of the air conditioner will generate a large induction surge voltage.

**CHECKING PRODUCT RECEIVED**

- Upon receiving this product, inspect it for any shipping damage. Claims for damage, either apparent or concealed, should be filed immediately with the shipping company.
- Check the model number, electrical characteristics (power supply, voltage and frequency) and accessories to determine if they are correct.  
The standard utilization of the unit shall be explained in these instructions.  
Therefore, the utilization of the unit other than those indicated in these instructions is not recommended.  
Please contact your local agent, as the occasion arises.

☑ • *The figures in this manual are based on the external view of a standard model. Consequently, the shape may differ from that of the air conditioner you have selected.*

# Table of Contents

1. General .....	1
1.1 Features .....	1
1.2 Product lineup .....	1
1.3 Nomenclature .....	1
1.4 Unit installation .....	2
1.5 Working range .....	2
1.6 Product appearance .....	2
2. Specifications .....	3
3. Outlines and dimensions .....	5
4. Electrical data .....	7
5. Blower data .....	8
6. Sound data .....	10
7. Refrigerant cycle .....	11
8. Wiring diagram .....	12
8.1 Electrical wiring diagrams .....	12
8.2 Control board picture .....	13
8.3 Common wiring .....	14
9. Field setting .....	15
10. Checking components .....	16
10.1 Check refrigerant system .....	16
10.2 Check parts unit .....	18
11. Disassembly and assembly for compressor and motor .....	19
12. Control logic description .....	20

# 1. GENERAL

## 1. General

### 1.1 Features

- Being equipped with TXV metering, supporting cooling and heating.
- Multi-speed ECM blower motor
- Selecting electric heater kits within available models.
- Up to 0.8W.C ESP.
- Being in accordance with ETL AHRI.

### 1.2 Product Lineup

Model (Btu/h)	24K	36K	48K	60K
Air Handler	●	●	●	●

●: available model

### 1.3 Nomenclature

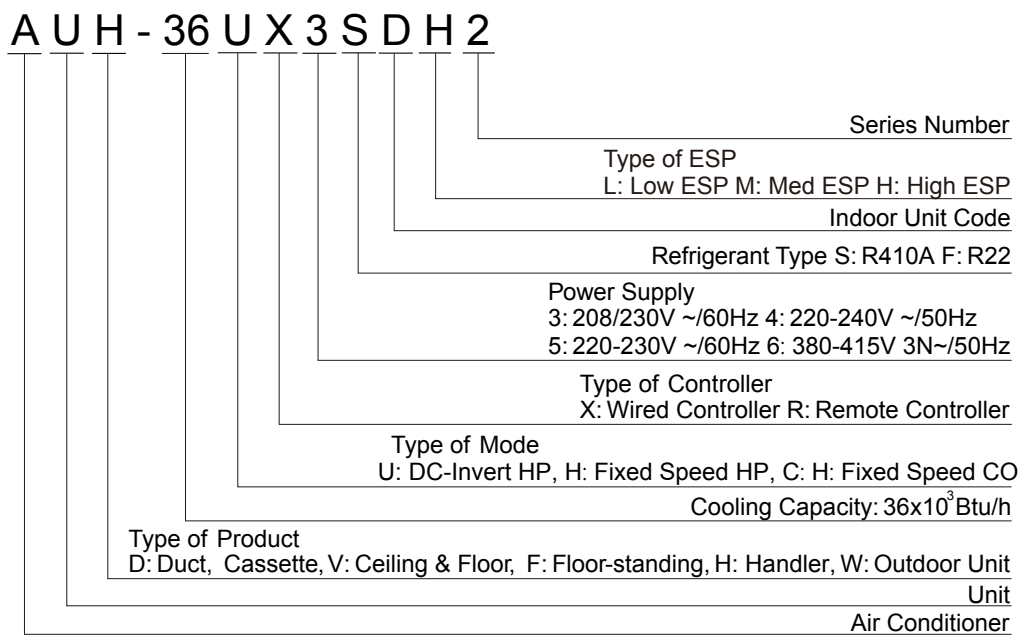

# 1. GENERAL

## 1.4 Unit Installation

1:1 system is the only compatible combination.

(Only one indoor unit can be connected with one outdoor unit.)

## 1.5 Working Range

Power Supply

<b>Working Voltage</b>	198V ~ 253V
<b>Voltage Imbalance</b>	Within a 3% deviation from each voltage at the main terminal of outdoor unit
<b>Starting Voltage</b>	Higher than 85% of the Rated Voltage

Storage Condition

Temperature -13~140°F (-25~60°C)

Humidity 30%~80%

## 1.6 Product Appearance

Model (Btu/h)	Indoor Unit
24K 36K 48K 60K	

## 2. SPECIFICATIONS

### 2. Specifications

Indoor model		24K	36K	48K	60K	
Type		US Duct	US Duct	US Duct	US Duct	
Power Supply		V/ph/Hz	208~230/1/60	208~230/1/60	208~230/1/60	
Cooling	Capacity	Btu/h	22000	34000	48000	56000
	Capacity (min.-max.)	Btu/h	6700-26000	11800-36800	18300-52000	18300-59400
	Capacity (min.-max.)	W	2227-7327	2814-10697	5363-15240	5363-17409
	Input	W	2180	3370	4750	6780
	Current	A	10.0	15.4	21.8	31.0
	EER2	W/W	2.96	2.96	2.96	2.42
	SEER2	Btu/(W.h)	16.5	18.0	17.5	17.0
	EER2	Btu/(W.h)	10.10	10.10	10.10	8.25
Heating	Capacity	Btu/h	23000	35000	47000	56000
	Capacity(min.-max.)	Btu/h	6700-26000	8900-38200	17600-52000	17600-57500
	Capacity Heating(Rated) @ 47°F	Btu/h	23000	35000	47000	56000
	Capacity Heating(Rated) @ 17°F	Btu/h	15000	24000	31000	34000
	Input	W	1980	2950	4170	5290
	Current	A	9.5	14.1	19.0	21.0
	HSPF2	Btu/(W.h)	9.0	9.5	8.5	8.5
	COP2	W/W	3.4	3.5	3.3	3.1
COP2	Btu/(W.h)	11.60	11.94	11.26	10.58	
Moisture Removal	L/h	2.2	4.5	5.5	7.50	
	Pts/h	4.64	9.5	11.6	15.80	
Min. Ampacity	A	Indoor3.3	Indoor4.8	Indoor6.8	Indoor6.8	
Max. td Fuse/Breaker	A	Indoor10	Indoor10	Indoor15	Indoor15	
Power Cable	No. × AWG	Indoor3×16,	Indoor3×16	Indoor3×16	Indoor3×16	
Communication Cable	No. × AWG	5×16	5×16	5×16	5×16	
Thermostat Type		Common 24V Thermostat	Common 24V Thermostat	Common 24V Thermostat	Common 24V Thermostat	
Indoor Fan Motor (Multi Speed ECM)	Qty	1	1	1	1	
	Model	ZWK702B006073	ZWK702B500026	ZKSD-560-8-50-14	ZKSD-560-8-58	
	Output	HP	1/3	1/2	3/4	3/4
	RLA	A	2.4~2.6	3.6~3.8	5.0~5.4	5.0~5.4
Speed	r/min	350~1400	350~1400	350~1400	350~1400	
Indoor Air Flow Rated	m <sup>3</sup> /h	1360	1905	2700	2900	
Indoor Air Flow Rated	CFM	800	1120	1588	1706	
Indoor Coil	Number of Rows		4	4	5	5
	Tube Pitch(a)	mm	21	21	21	21
		in	0.827	0.827	0.827	0.827
	Row Pitch(b)	mm	13.6	13.6	13.6	13.6
		in	0.535	0.535	0.535	0.535
	Fin Spacing	mm	1.4	1.4	1.5	1.5
		Fins Per in	18	18	17	17
	Fin Type		Hydrophilic Aluminium	Hydrophilic Aluminium	Hydrophilic Aluminium	Hydrophilic Aluminium
Tube outside Diameter and Type	mm	Φ7, Innergroove Tube	Φ7, Innergroove Tube	Φ7, Innergroove Tube	Φ7, Innergroove Tube	
Coil	mm	2(444×420×54.4)	2(444×420×54.4)	2 (509×546×68)	2 (509×546×68)	

## 2. SPECIFICATIONS

Indoor model			24K	36K	48K	60K
Indoor Coil	Dimension(W×H×D)	in	2(17-1/2×16-1/2×2-1/8)	2(17-1/2×16-1/2×2-1/8)	2 (20×21-1/2×2-11/16)	2 (20×21-1/2×2-11/16)
	Number of Circuits		8	8	12	12
ESP	Rated	In.W.C. (Pa)	0.18 ( 45 )	0.228 ( 57 )	0.276 ( 70 )	0.276 ( 70 )
	Range	In.W.C. (Pa)	0-0.8 ( 0-200 )	0-0.8 ( 0-200 )	0-0.8 ( 0-200 )	0-0.8 ( 0-200 )
Indoor Noise Level (Hi)		dB(A)	55	57	64	65
Throttle Type			TXV	TXV	TXV	TXV
Indoor Unit	Dimension (W×H×D)	mm	500×1170×550	500×1170×550	560×1370×610	560×1370×610
		inch	19-5/8 × 46-1/8 × 21-5/8	19-5/8 × 46-1/8 × 21-5/8	22×53-7/8×24	22×53-7/8×24
	Packing(W×H×D)	mm	570×1260×645	570×1260×645	640×1410×710	640×1410×710
		inch	22-1/2×49-5/8×25-3/8	22-1/2×49-5/8×25-3/8	25-1/4×55-1/2×28	25-1/4×55-1/2×28
	Net Weight	kg	61.5	63.5	85	85
		lbs	135.5	140	187.2	187.2
	Shipping Weight	kg	72	74	97	97
		lbs	158.6	163.1	214	214
Drainage Water Pipe Diameter		inch	3/4"	3/4"	3/4"	3/4"
Design Pressure	H/L	MPa	3.8/1.6	3.8/1.6	3.8/1.6	3.8/1.6
		PSIG	550/240	550/240	550/240	550/240
Qty' per 20' /40' /40'HQ (Indoor Unit)		Set	36/72/144	36/72/144	39/78/102	39/78/102

### NOTE:

#### 1. Test Conditions:

##### 1.1 Rated Capacity Test Conditions:

Cooling: Indoor: DB 80.0°F (26.7°C) /WB 67.0°F (19.4°C)

Outdoor: DB 95.0°F (35.0°C) /WB 75.0°F (23.9°C)

Heating: Indoor: DB 70.0°F (21.1°C) /WB 60.0°F (15.6°C)

Outdoor: DB 47°F (8.3°C) /WB 43°F (6.1°C)

##### 1.2 SEER & HSPF Test Standard: AHRI 210/240.

#### 2. The Sound Pressure Level is based on the following conditions:

Indoor Unit:

Air Handler Unit

Measure the noise value of the point 3.28 ft(1.0m) in front of the outlet of the wind tunnel and 3.28 ft (1.0m) high from the bottom of the unit.

#### 3. The above data was measured in an anechoic chamber. Please take into consideration the reflected sound of your specific application environment.

#### 4. All specifications are subject to change by the manufacturer without prior notice.

### 3. OUTLINES AND DIMENSIONS

### 3. Outlines and Dimensions

24K/36K

Unit : in.(mm)

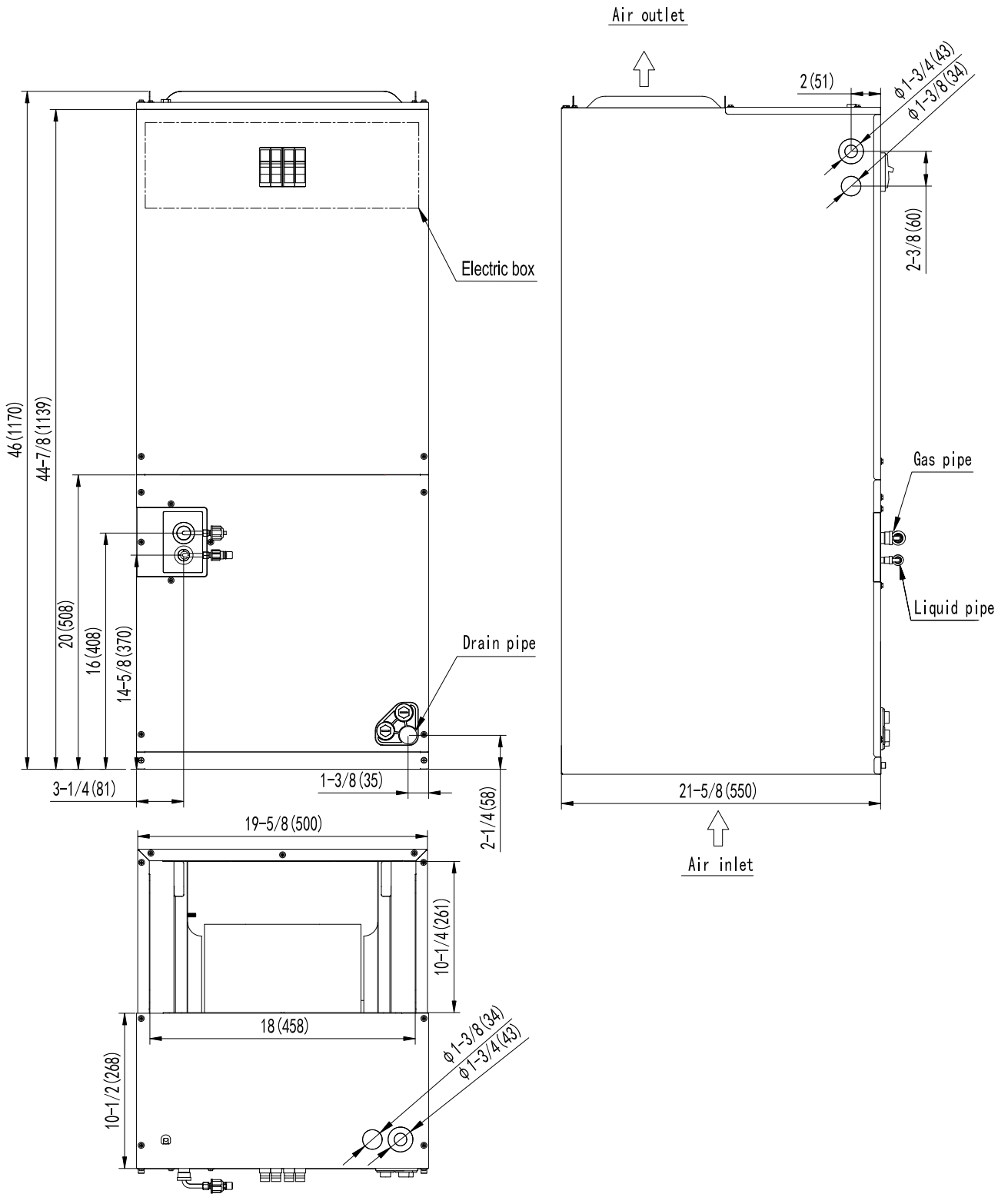

### 3. OUTLINES AND DIMENSIONS

48K/60K

Unit : in.(mm)

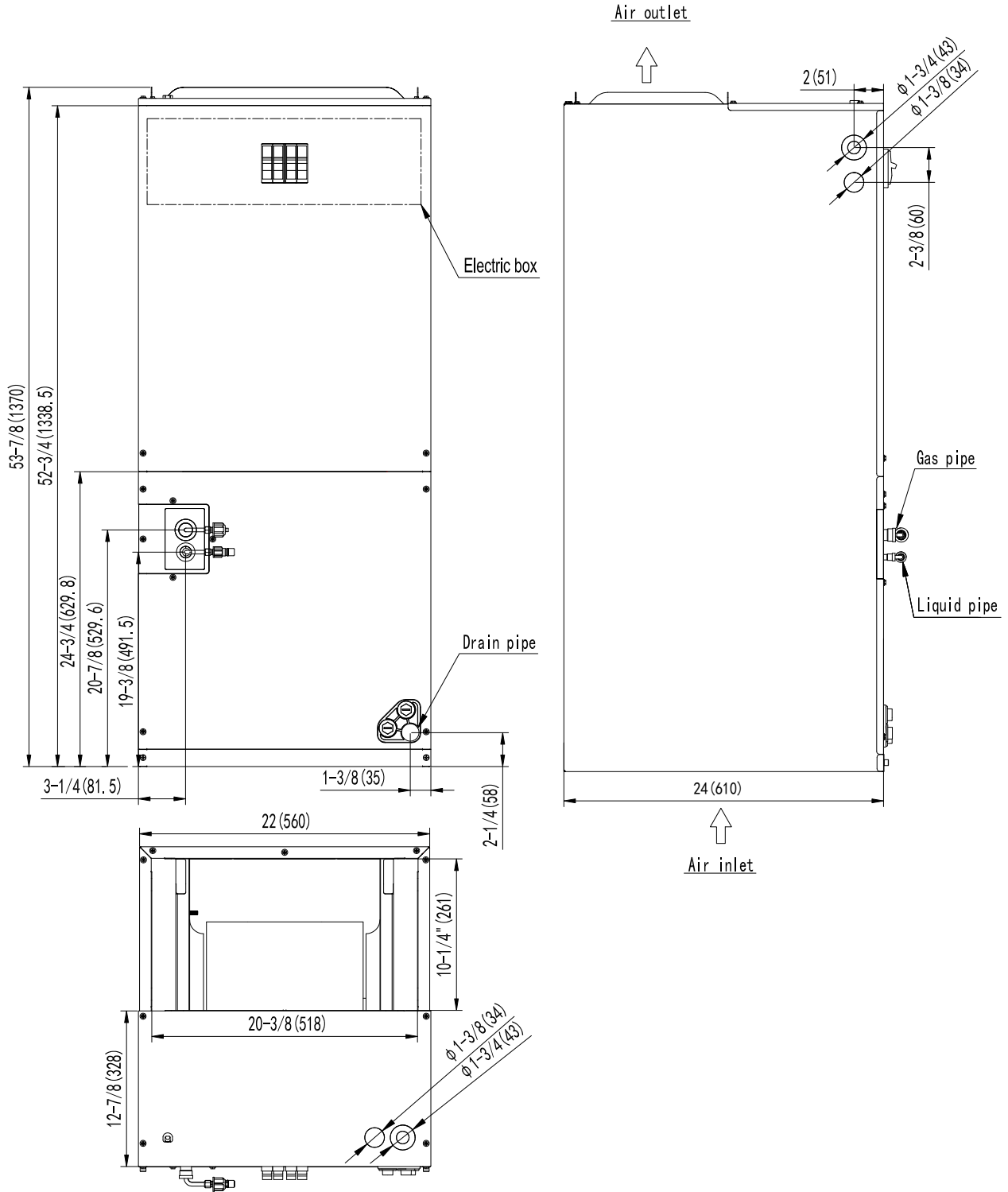

## 4. ELECTRICAL DATA

### 4. Electrical Data

Indoor Unit	Power Supply			Applicable Voltage		ELB	
	Voltage (V)	PH	Frequency (Hz)	Umin. (V)	Umax. (V)	Nominal Current (A)	Nominal Sensitive Current (mA)
24K/36K/ 48K/60K	208/230	1	60	198	253	15	30

**NOTE:**

1. The above compressor data is based on 100% capacity combination of indoor units at the rated operating frequency.
2. This data is based on the same conditions as the nominal heating and cooling capacities.
3. The compressor is started by an inverter, resulting in extremely low starting current.

## 5. BLOWER DATA

### 5. Blower Data

Airflow performance data is based on cooling performance with a coil and no filter in place. Check the performance table for appropriate unit size selection. External static pressure should stay within the minimum and maximum limits shown in the table below in order to ensure proper cooling, heating , and electric heating operation.

**Air Flow Table**

Air Handler Model	Motor Speed		External Static Pressure in.H2O[KPa]								
			0[0]	0.1[0.02]	0.18[0.045]	0.3[0.07]	0.4[0.1]	0.5[0.12]	0.6[0.15]	0.7[0.17]	0.8[0.20]
24K	Tap(1) -Default Setting	CFM	815	792	752	709	676	653	615	566	512
		Watts	94	102	110	123	130	139	148	157	167
	Tap(2)	CFM	862	828	792	735	705	673	661	618	561
		Watts	106	114	125	137	145	154	161	170	177
	Tap(3)	CFM	975	940	906	859	853	803	769	735	681
		Watts	148	155	165	178	185	193	203	213	219
	Tap(4)	CFM	1055	1024	995	948	922	895	864	825	779
		Watts	197	204	214	228	234	241	251	258	267

**Air Flow Table**

Air Handler Model	Motor Speed		External Static Pressure in.H2O[KPa]								
			0[0]	0.1[0.02]	0.18[0.045]	0.3[0.07]	0.4[0.1]	0.5[0.12]	0.6[0.15]	0.7[0.17]	0.8[0.20]
36K	Tap(1) -Default Setting	CFM	1264	1216	1172	1135	1096	1028	954	890	839
		Watts	215	222	233	238	244	254	261	266	274
	Tap(2)	CFM	1350	1314	1269	1206	1116	1082	1050	990	930
		Watts	257	264	274	282	292	297	302	309	316
	Tap(3)	CFM	1460	1409	1368	1323	1266	1192	1122	1060	999
		Watts	280	288	295	304	313	323	333	340	348
	Tap(4)	CFM	1526	1479	1441	1399	1350	1292	1221	1148	1088
		Watts	342	348	355	363	371	381	394	401	406

[!] Required 350-450CFM/ton range.

[!] Airflow based upon Air Handler Unit operates at 230V with no electric heater kit and no filter. Airflow at 208V is approximately the same as 230V.

[!] CFM means Standard Cubic Foot per Hour.

[!] When there is an electric heater, please set the fan speed based on the air volume that the electric heater needs (not less than 350CFM/TON).

## 5. BLOWER DATA

### Air Flow Table

Air Handler Model	Motor Speed		External Static Pressure in.H2O[KPa]								
			0[0]	0.1[0.02]	0.18[0.045]	0.3[0.07]	0.4[0.1]	0.5[0.12]	0.6[0.15]	0.7[0.17]	0.8[0.20]
48K	Tap(1) -Default Setting	CFM	1756	1701	1626	1579	1520	1468	1425	1386	1346
		Watts	348	357	369	378	387	395	407	410	424
	Tap(2)	CFM	1799	1746	1678	1634	1571	1522	1449	1402	1241
		Watts	366	377	388	398	410	419	428	444	440
	Tap(3)	CFM	1828	1794	1749	1719	1670	1633	1589	1553	1510
		Watts	376	387	401	413	428	437	452	465	482
	Tap(4)	CFM	1888	1855	1813	1782	1735	1701	1665	1626	1585
		Watts	415	428	445	456	469	481	495	510	525

### Air Flow Table

Air Handler Model	Motor Speed		External Static Pressure in.H2O[KPa]								
			0[0]	0.1[0.02]	0.18[0.045]	0.3[0.07]	0.4[0.1]	0.5[0.12]	0.6[0.15]	0.7[0.17]	0.8[0.20]
60K	Tap(1) -Default Setting	CFM	1838	1810	1770	1760	1670	1633	1589	1553	1510
		Watts	376	387	401	413	428	437	452	465	482
	Tap(2)	CFM	1888	1855	1813	1782	1751	1701	1665	1626	1585
		Watts	415	428	445	456	469	481	495	510	525
	Tap(3)	CFM	1971	1941	1893	1864	1820	1786	1755	1718	1673
		Watts	472	485	501	513	530	540	558	568	586
	Tap(4)	CFM	2056	2022	1978	1950	1907	1878	1826	1801	1750
		Watts	533	545	562	575	592	603	619	631	638

[!] Required 350-450CFM/ton range.

[!] Airflow based upon Air Handler Unit operates at 230V with no electric heater kit and no filter. Airflow at 208V is approximately the same as 230V.

[!] CFM means Standard Cubic Foot per Hour.

[!] When there is an electric heater, please set the fan speed based on the air volume that the electric heater needs (not less than 350CFM/TON).

# 6. SOUND PRESSURE DATA

## 6. Sound Pressure Data

Indoor Unit

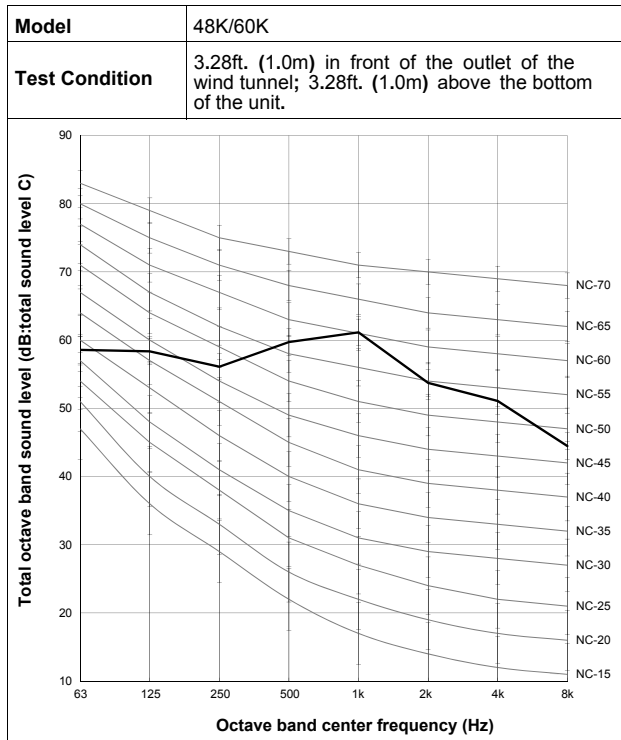
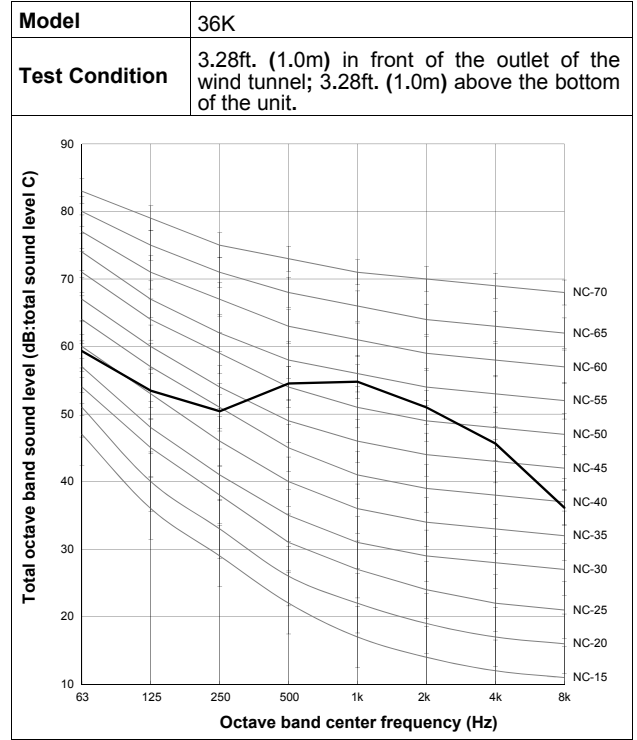
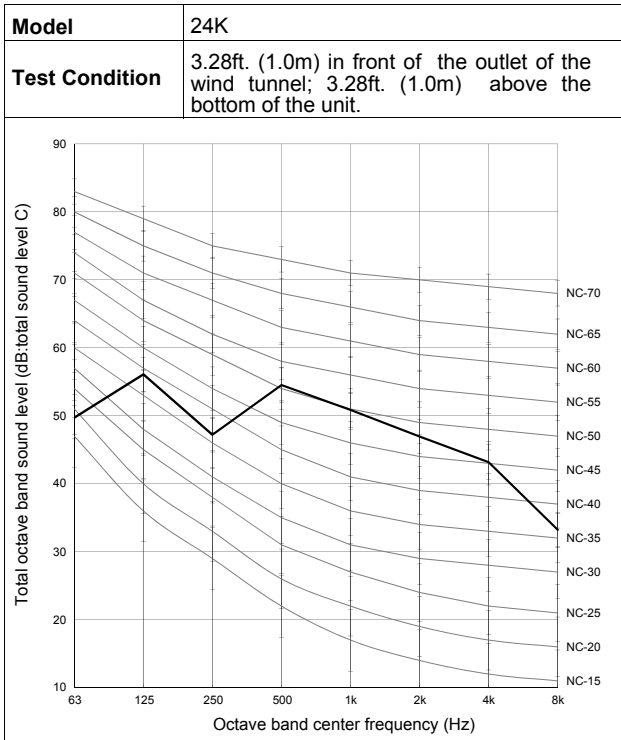

## 7. REFRIGERANT CYCLE

### 7. Refrigerant Cycle

Indoor Unit

24K/36K/48K/60K

→ Cooling Cycle

--- Heating Cycle

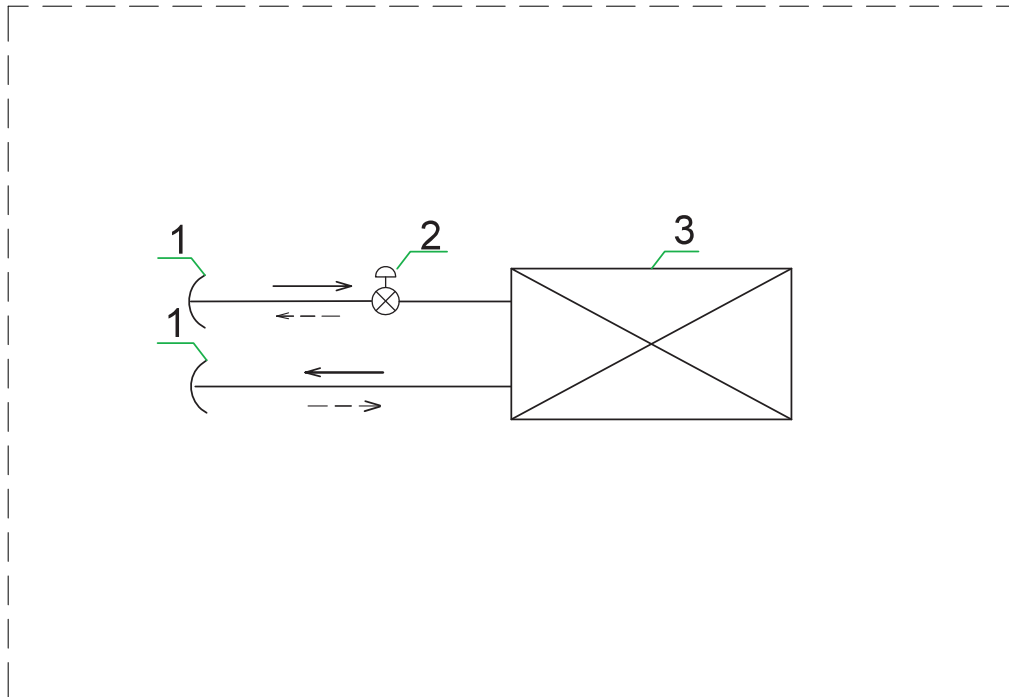

**List of Components**

1	Hexagon Nut
2	TXV
3	Indoor Heat Exchanger

## 8. WIRING DIAGRAM

### 8. Wiring Diagram

#### 8.1 Electrical Wiring Diagram

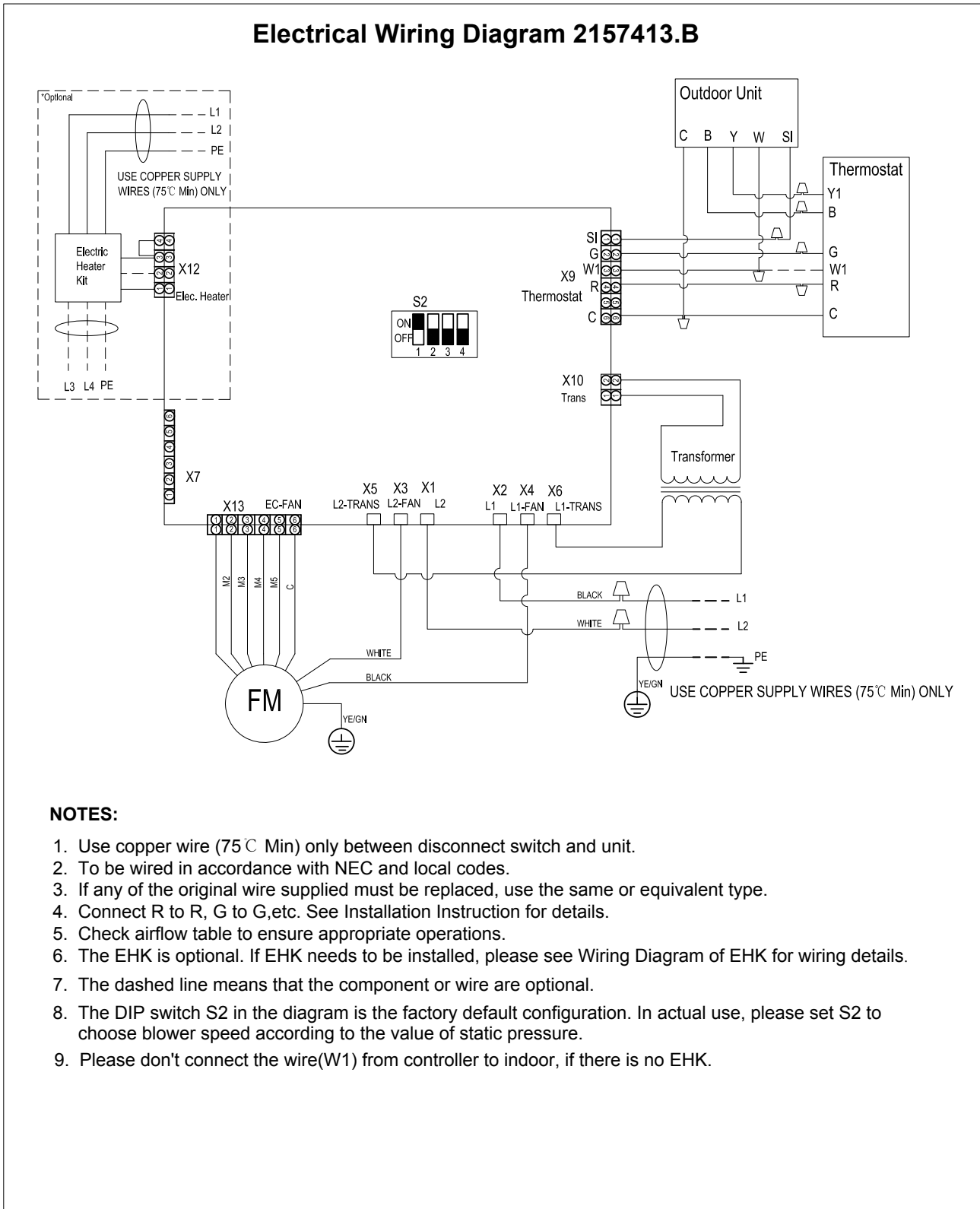

## 8. WIRING DIAGRAM

### 8.2 Control Board Picture

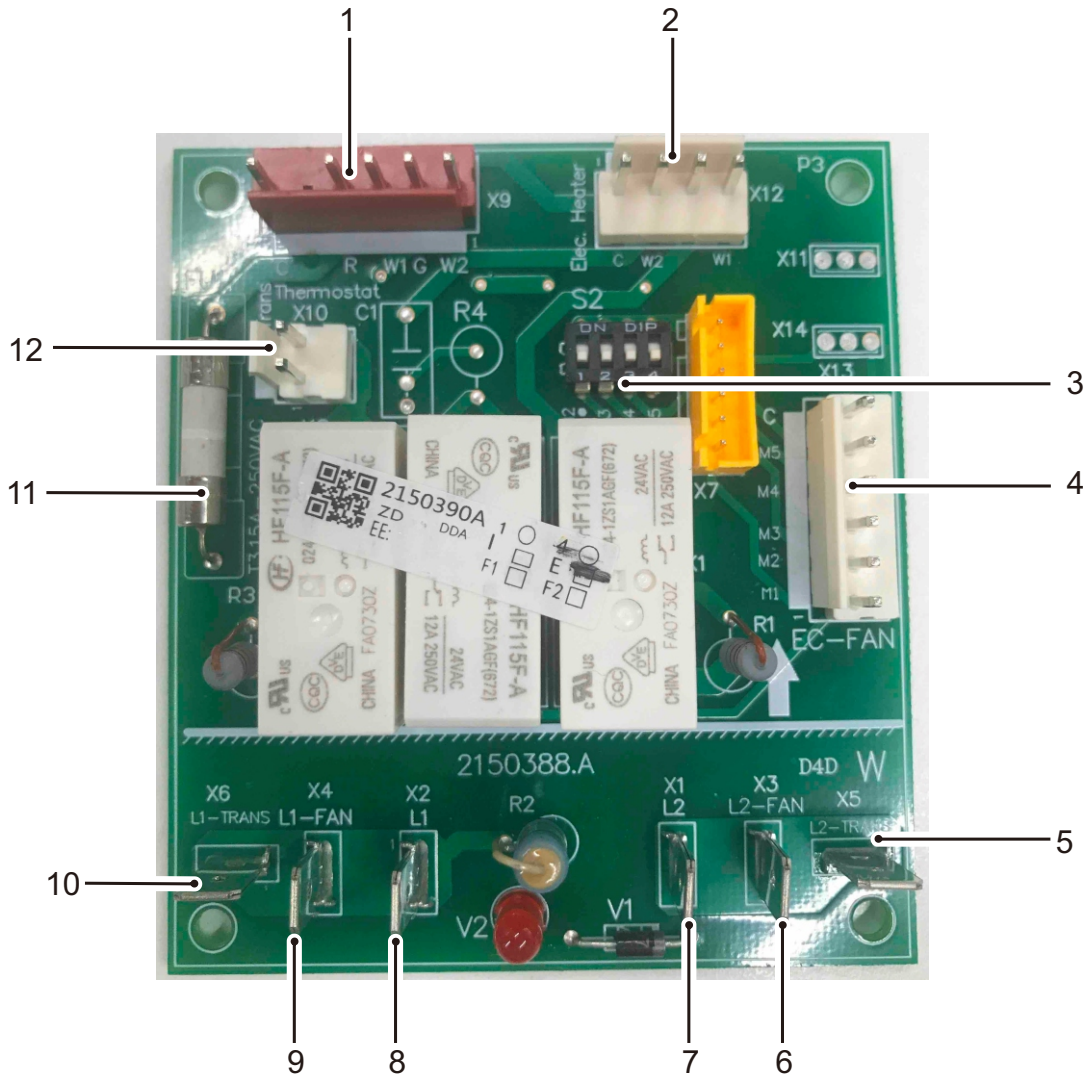

NO.	Description	NO.	Description
1	Thermostat	7	AC Power L2
2	Electrical Heat Kit	8	AC Power L1
3	DIP Switch for Blower Speed	9	L1 for Fan Motor
4	Fan Motor Control	10	L1 for Transformer
5	L2 for Transformer	11	Fuse
6	L2 for Fan Motor	12	AC 24V from Transformer

## 8. WIRING DIAGRAM

### 8.3 Common Wiring

#### Wiring Diagram

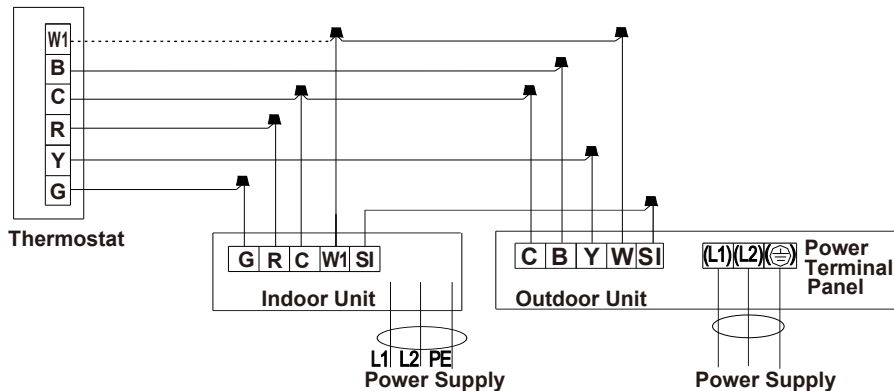

#### NOTE:

- (1) Do not connect dashed line when electric heater is not used.
- (2) Wiring must be performed according to wiring diagram that pasted on indoor unit.
- (3) The SI wire between the indoor and outdoor units is not indispensable, especially when the outdoor unit is connected to an indoor unit of a different brand. It is more energy-saving when the outdoor unit is connected to an indoor unit of the same brand by SI wire. However, it still can run without it.
- (4) Since the thermostat is locally provided, the terminal block in the diagram may differ from the actual one. The letter Y is the same as Y1.

#### Recommended Wire Size

Model (Btu/h)	Power Supply	ELB		Power Source Cable Size	Transmitting Cable Size	Thermostat Signal Size	Fuse or Circuit Breaker (A)
		Rated Current (A)	Nominal Sensitive Current (mA)				
24K~60K	208/230V ~/60Hz	15	30	3×16AWG	5×16AWG	5×18AWG/ 6×18AWG	15

Max. Running Current (A): REFER TO NAMEPLATE









#### NOTE:

1. Follow local codes and regulations when selecting field wires, and all the above are the minimum wire size.
2. When transmitting cable is longer than 262ft. (80m), a larger wire size should be selected.
3. Install main switch and ELB for each system separately. Select the high response type ELB that is acted within 0.1 second.
4. If auxiliary heater is required and already installed on indoor unit, power source cable should be installed separately and the size should be selected in accordance with UL.

## 9. FIELD SETTING

### 9. Filed Setting

Static Pressure Setting:

DIP Switch S2 Setting	Blower Speed Tap	Fan Speed Select	Static Pressure (W.C.[kPa]) 24K	Static Pressure (W.C.[kPa]) 36K	Static Pressure (W.C.[kPa]) 48K/60K
ON  OFF 	2	Medium Low (Default setting)	0.18[0.045]	0.24[0.057]	0.28[0.07]
ON  OFF 	3	Medium	0.25[0.08]	0.4[0.1]	0.4[0.1]
ON  OFF 	4	Medium High	0.58[0.145]	0.58[0.145]	0.58[0.145]
ON  OFF 	5	High	0.8[0.2]	0.8[0.2]	0.8[0.2]

**NOTE:** Symbol " ■ " indicates the position of the DIP switch.  
 Symbol " □ " indicates any position of ON or OFF.

# 10. CHECKING COMPONENTS

## 10. Checking Components

### 10.1 Check Refrigerant System

#### TEST SYSTEM FLOW:

Conditions: ① Compressor is running.

The air condition should be installed in good ventilation.

Tool: Pressure Gauge Technique: ① see ② feel ③ test

See ----- Tube Defrost.

Feel ----- The Difference between Tube's Temperature.

Test ----- Test Pressure.

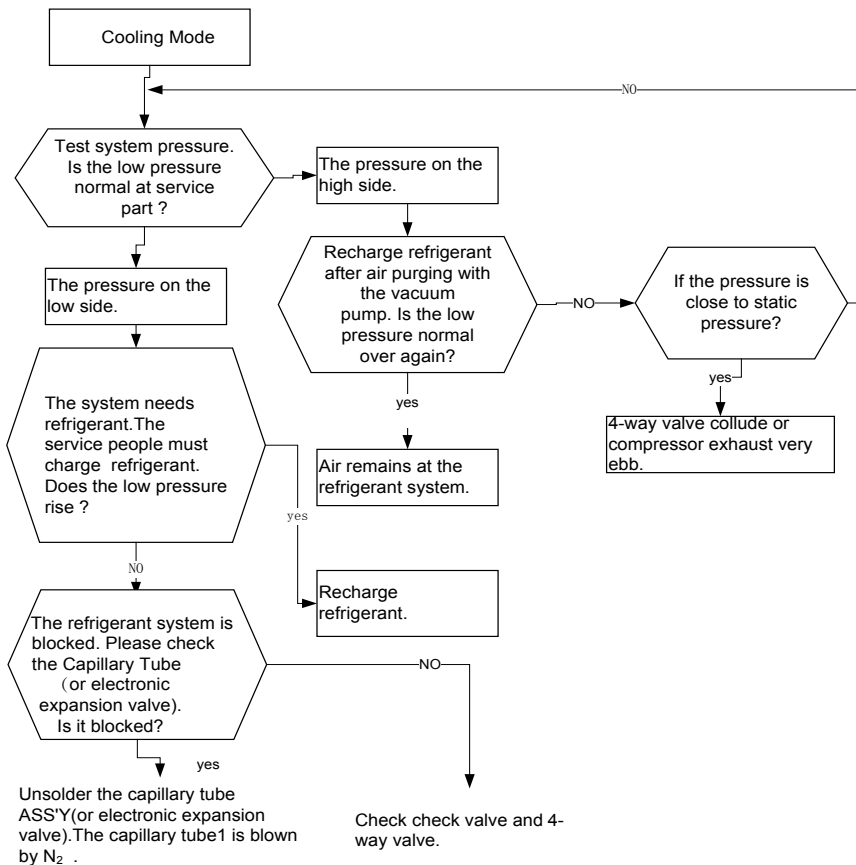
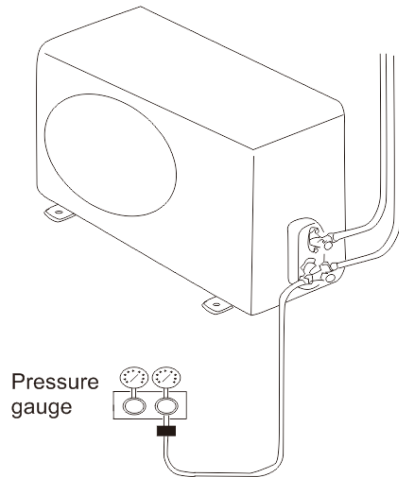

# 10. CHECKING COMPONENTS

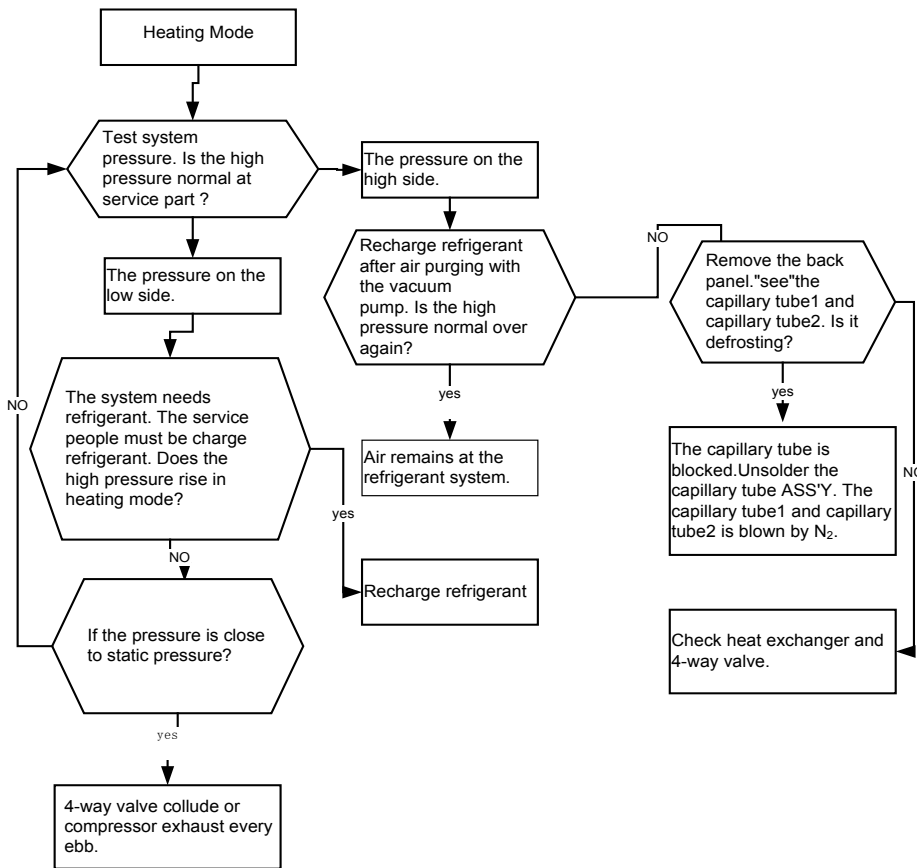

## 10. CHECKING COMPONENTS

### 10.2 Check Parts Unit

#### 1. Indoor Unit Fan Motor

Duct motor model

24K: ZWK702B006073

36K: ZWK702B500026

48K: ZKSD-560-8-50-14

60K: ZKSD-560-8-58

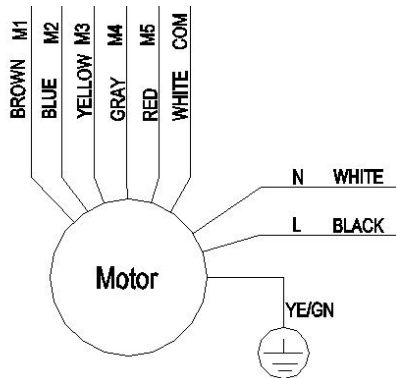

Test in resistance.

TOOL: Multimeter.

Test the resistance of the main winding. The indoor fan motor fails if the resistance of main winding is 0(short circuit) or  $\infty$  (open circuit).

Test in voltage

TOOL: Multimeter.

Insert screwdriver to rotate indoor fan motor slowly for 1 revolution or over, and measure voltage "YELLOW" and "GND" on motor. The voltage repeat 0V DC and 5V DC.

NOTES:

Please don't hold motor by lead wires.

Please don't plug IN/OUT the motor connector while power is ON.

Please don't drop hurl or dump motor against hard material. Malfunction may not be observed at early stage after such shock. But it may be found later, this type of mishandling void our warranty.

# 11. DISASSEMBLY AND ASSEMBLY FOR MOTOR

## 11. Disassembly and Assembly for Motor

### Indoor Unit

24K/36K/48K/60K

Important: Before disassembly and assembly, make sure that the power to the system has been disconnected and verified as voltage free.

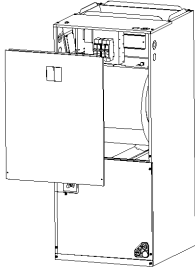
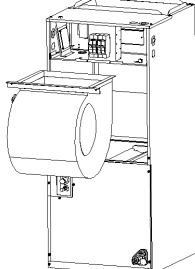
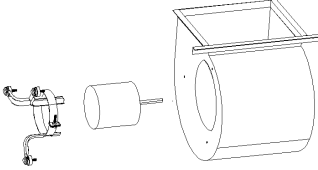
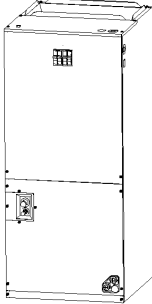
Step	Illustration	Handling Instruction
1. Remove the top panel and unplug the motor cables.		Use screwdriver to remove the electric box cover and unplug the motor cables in electric box.
2. Take out the fan snail shell unit.		Use screwdriver to unscrew two bolts from the top of the unit.
3. Remove the motor and the motor mount.		Use wrench to unscrew three bolts from the side of shell.
4. Reassembly of the unit. Assemble the unit		Reassemble the unit in the reverse order of disassembly and test operation.

## 12. HEATER KIT

### 12. Heater Kit (Optional)

Electric Heat Kit Model	Air Handler Model	Electric Heat (kW)	MIN. Circuit Ampacity		MAX. Fuse or Breaker (HACR) Ampacity		Fan Speed Tap			
			230VAC	208VAC	230VAC	208VAC	2	3	4	5
21-4245-01	24K	5	28.3	25.9	30	30	●	●	●	●
21-4245-02		7.5	40.7	37.2	45	40	×	●	●	●
21-4245-03		10	53.2	48.5	60	50	×	×	●	●
21-4245-01	36K	5	29.8	27.4	30	30	●	●	●	●
21-4245-02		7.5	42.2	38.7	45	40	×	●	●	●
21-4245-03		10	54.7	49.9	60	50	×	×	●	●
21-4245-04		15	42.2+36.9	38.6+33.8	45+40	40+35	×	×	×	●
21-4245-01	48K/60K	5	31.8	29.4	35	30	●	●	●	●
21-4245-02		7.5	44.8	40.7	45	45	×	●	●	●
21-4245-03		10	56.7	51.9	60	55	×	×	●	●
21-4245-04		15	44.8+36.9	40.7+33.8	50+40	50+35	×	×	●	●
21-4245-05		20	56.7+49.9	51.9+45.2	60+50	60+50	×	×	×	●

● : available  
 × : unavailable

**NOTES:**

1. To be wired in accordance with NEC and local codes.
2. Fan speed selection: 1--Medium low; 2--Medium; 3--Medium high; 4--High.
3. The heater kit must be connected to the power supply separately.
4. Check if heat kit is suitable for AHU 3-way position installation.
5. Ampacities for MCA and Fuse/breaker including the blower motor.
6. Heat pump systems require specified airflow. Each ton of cooling requires between 350 and 450 cubic feet of air per minute(CFM), or 400 CFM nominally.

# **Hisense**

Product improvement, specifications and appearance in this manual are subject to change without prior notice.