

Hisense Hi-ULTRA Xtreme 12K 230V



Submittal Data: AST-12UW3SXEDH02 AST-12UW3SXEDH02G
12,000 BTU/H, Wall-Mounted Heat Pump System

Job Name:	Location:		
Purchaser:	Submitted by:		
Submitted to:	Reference:	Approval:	Construction:
Engineer:	Date:	Application:	

- 1\ENERGY STAR certified + Xtreme Heat, up to 94% Heating at 5°F
- 2\WiFi built-in, Available ConnectLife APP for both iOS and Android to control your room temp. with smartphone
- 3\Anti corrosion heat exchanger for Hesse-WiFi built-in, Available operation
- 4\Universal indoor units with Hi-Multi
- 5\Heating below -20°C (-4°F)
- 6\Chassis Electric heater
- 7\ Easy installation
- 8\ "I feel" in remote controller
- 9\ 2 -Way Drain Connection (Left or Right)
- 10\Washable High Definition Filter
- 11\ Auto Restart
- 12\Indoor Self-Cleaning w/ FrostClean Technology
- 13\Optional Wired Controller

Images provided for reference purposes only



Performance:

Cooling	Cooling Capacity	Btu/h	12000
	Cooling Capacity Range	Btu/h	3000~14000
	Rated Input-Cooling	W	940
Heating at 47°F	Heating Capacity	Btu/h	12000
	Heating Capacity Range	Btu/h	3000~16000
	Rated Input-Heating	W	940
Heating at -8.3 °C (17°F AHRI)	Heating Capacity	Btu/h	6,800
Heating at -15 °C (5 °F)	Heating Capacity	Btu/h	8,400
Heating at -20 °C (-5 °F)	Heating Capacity	Btu/h	8,000
Heating at -25 °C (-13 °F)	Heating Capacity	Btu/h	7,000
Heating at -30 °C (-22 °F)	Heating Capacity	Btu/h	6,000

Efficiency:

SEER	23
SEER2	23.5
HSPF	11.5
HSPF2	9.5
EER -BTU/W	12.70
COP -BTU/W	12.76

Outdoor Operating Temperature Range:

Working Temperature Range - Cooling	(°C/°F)	-15°C~46°C ; (5°F~115°F)
Working Temperature Range - Heating	(°C/°F)	-30°C~24°C ; (-22°F~75°F)

Electrical:

Power Supply	208-230V~ 60Hz, 1Ph	
Rated Current	Cooling (A)	4.3
	Heating (A)	4
Current Range	Cooling (A)	1.2-7.0
	Heating (A)	1.2-7.0
Max Fuse Size/Fusable Max.	A	15
Min.Circuit Ampacity	A	9



Submittal Data: AST-12UW3SXEDH02 AST-12UW3SXEDH02G
12,000 BTU/H, Wall-Mounted Heat Pump System

Indoor Unit Specifications:

Fan Motor Output	W	25
Fan Motor Speed (H/M/L)	RPM	1150/990/800
Moisture Removal	L/H.r	1.2
Air Circulation (Ultra\High\Medium\Low)	m3/h	640 / 550 / 430
Sound Pressure(Higer/H/M/L/silence)	dB (A)	42/40/36/32/29
Net Dimensions WxHxD	mm	815×280×220
	in.	32 1/16x11x8 11/16
Net Weight	kg	8.5
	lbs.	18.7

Outdoor Unit Specifications:

Fan Motor Output	W	30
Fan Motor Speed (H/M/L)	RPM	800
Sound pressure	dB (A)	53
Refrigerant charge volume	g	R410A/1180
Net Dimensions WxHxD	mm	810x585x280
	in.	31 7/8x23x11
Net Weight	kg	33
	lbs.	72.8
Liquid Pipe	in.	1/4
Gas Pipe	in.	3/8
Maximum Piping Length	m.	20
Maximum Height Difference	m.	10

Model No.	Description:
RCH-RTY5-0	Remote Controller
YXE-C01U1	Wired Controller (Optional)

Indoor Unit Outline and Dimensions:

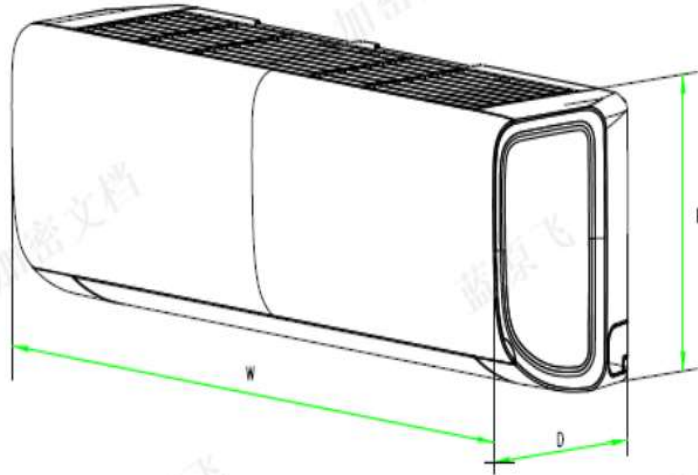

	W	H	D
mm	815	280	220
in	32.1	11.0	8.7

Outdoor Unit Outline and Dimensions:

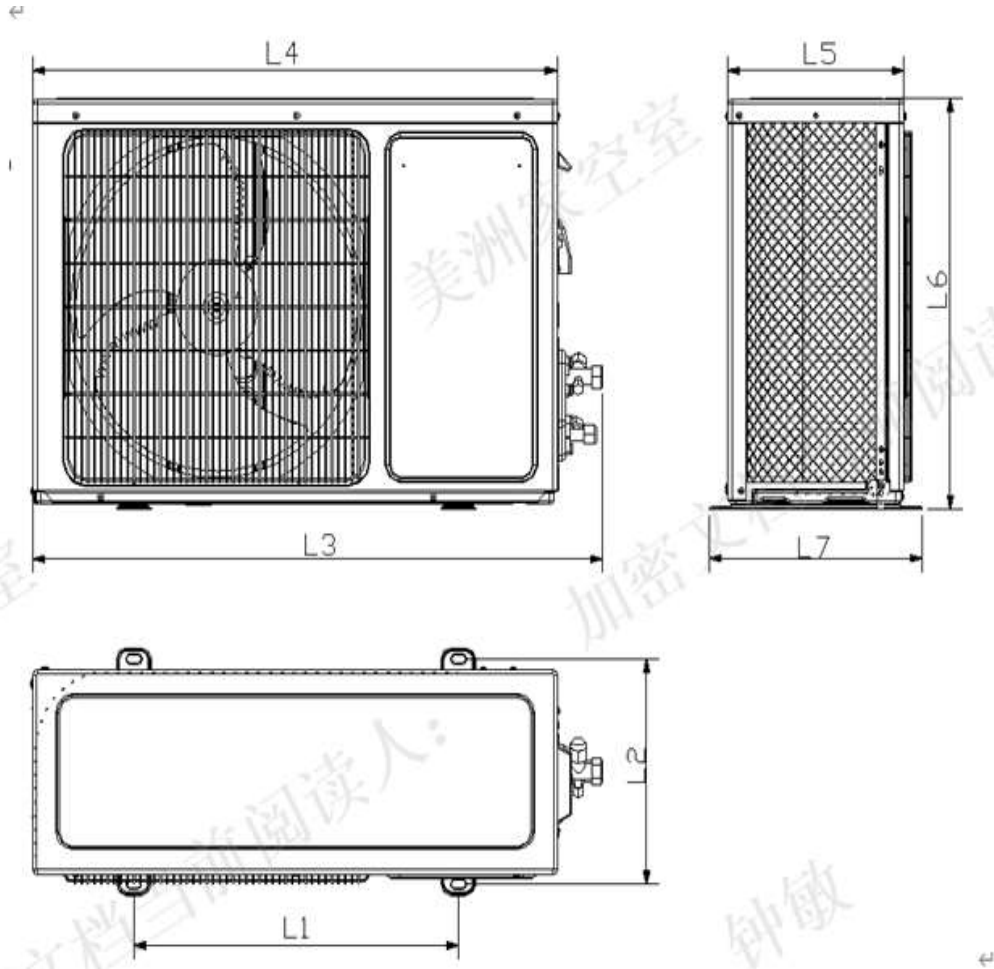

	L1	L2	L3	L4	L5	L6	L7
mm	510	310	873	810	280	585	338
in	20.08	12.20	34.37	31.89	11.02	23.03	13.31