

Hisense Hi-ULTRA Xtreme 18K 230V



Submittal Data: AST-18UW3SBBDH01 AST-18UW3SBBDH01G
18,000 BTU/H, Wall-Mounted Heat Pump System

Job Name:	Location:		
Purchaser:	Submitted by:		
Submitted to:	Reference:	Approval:	Construction:
Engineer:	Date:	Application:	

- 1\ENERGY STAR certified + Xtreme Heat, up to 94% Heating at 5°F
- 2\WiFi built-in, Available ConnectLife APP for both iOS and Android to control your room temp. with smartphone
- 3\Anti corrosion heat exchanger for Hesse-WiFi built-in, Available operation
- 4\Universal indoor units with Hi-Multi
- 5\Heating below -20°C (-4°F)
- 6\Chassis Electric heater
- 7\ Easy installation
- 8\ "I feel" in remote controller
- 9\ 2 -Way Drain Connection (Left or Right)
- 10\Washable High Definition Filter
- 11\ Auto Restart
- 12\Indoor Self-Cleaning w/ FrostClean Technology
- 13\Optional Wired Controller



Images provided for reference purposes only

Performance:

Cooling	Cooling Capacity	Btu/h	18,000
	Cooling Capacity Range	Btu/h	4500~20000
	Rated Input-Cooling	W	1360
Heating at 47°F	Heating Capacity	Btu/h	19,000
	Heating Capacity Range	Btu/h	5500~23000
	Rated Input-Heating	W	1620
Heating at -8.3 °C (17°F AHRI)	Heating Capacity	Btu/h	10,500
Heating at -15 °C (5 °F)	Heating Capacity	Btu/h	13,300
Heating at -20 °C (-5 °F)	Heating Capacity	Btu/h	12,800
Heating at -25 °C (-13 °F)	Heating Capacity	Btu/h	12,500
Heating at -30 °C (-22 °F)	Heating Capacity	Btu/h	12,000

Efficiency:

SEER	20.50
SEER2	20.5
HSPF	10.50
HSPF2	9.5
EER -BTU/W	13.00
COP -BTU/W	11.97

Outdoor Operating Temperature Range:

Working Temperature Range - Cooling	(°C/°F)	-15°C~46°C ; (5°F~115°F)
Working Temperature Range - Heating	(°C/°F)	-30°C~24°C ; (-22°F~75°F)

Electrical:

Power Supply	208/230V,1Ph,60Hz	
Rated Current	Cooling (A)	5.95
	Heating (A)	7
Current Range	Cooling (A)	1.5-12
	Heating (A)	1.5-12
Max Fuse Size/Fusable Max.	A	20
Min.Circuit Ampacity	A	15



Submittal Data: AST-18UW3SBBDH01 AST-18UW3SBBDH01G
18,000 BTU/H, Wall-Mounted Heat Pump System

Indoor Unit Specifications:

Fan Motor Output	W	35
Fan Motor Speed (H/M/L)	RPM	1200/1040/880
Moisture Removal	L/H.r	1.5
Air Circulation (Ultra\High\Medium\Low)	m3/h	950 / 800 / 650
Sound Pressure(Higer/H/M/L/silence)	dB (A)	48/45/41/39/35
Net Dimensions WxHxD	mm	1085×315×235
	in.	42 11/16x12 3/8 x9 1/4
Net Weight	kg	13.5
	lbs.	29.8

Outdoor Unit Specifications:

Fan Motor Output	W	60
Fan Motor Speed (H/M/L)	RPM	840
Sound pressure	dB (A)	58
Refrigerant charge volume	g	R410A/1900
Net Dimensions WxHxD	mm	860x650x310
	in.	33 7/8x25 9/16x12 3/16
Net Weight	kg	46
	lbs.	101.4
Liquid Pipe	in.	1/4
Gas Pipe	in.	1/2
Maximum Piping Length	m.	20
Maximum Height Difference	m.	10

Model No.	Description:
RCH-RTY5-0	Remote Controller
YXE-C01U1	Wired Controller (Optional)

Indoor Unit Outline and Dimensions:

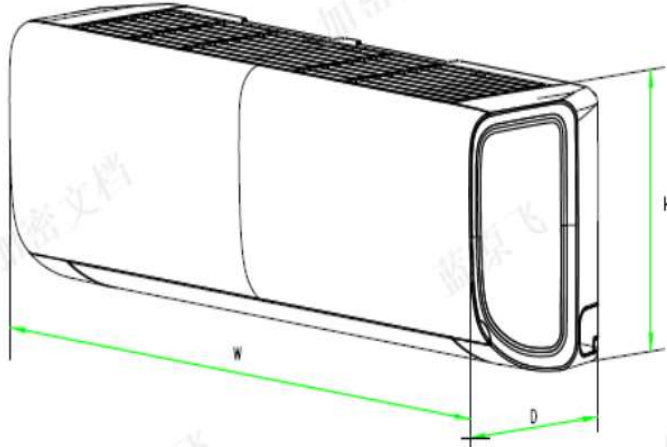

	W	H	D
mm	1085	315	235
in	42.7	12.4	9.3

Outdoor Unit Outline and Dimensions:

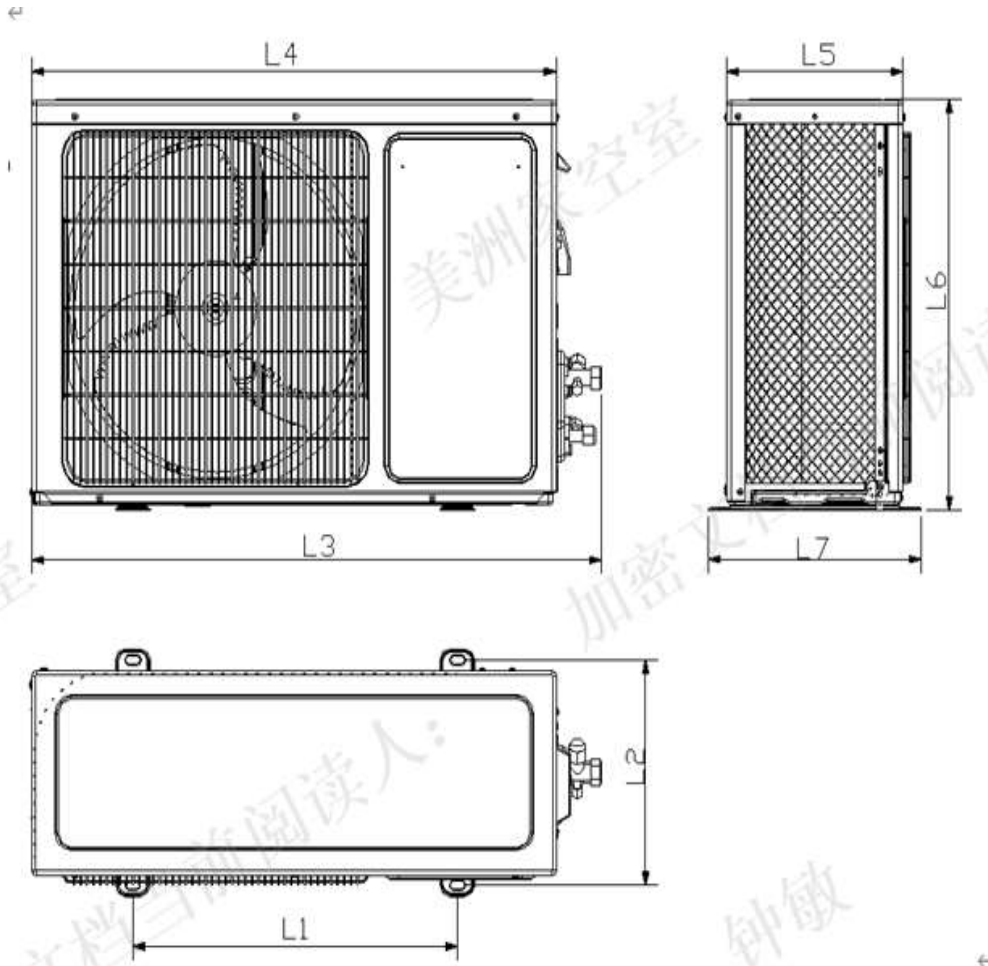

	L1	L2	L3	L4	L5	L6	L7
mm	542	341	935	860	310	650	368
in	21.34	13.43	36.81	33.86	12.20	25.59	14.49