

Hisense Hi-ULTRA Xtreme 24K 230V

Submittal Data: AS-24UW3SKKVT00 AS-24UW3SKKVT00G
24,000 BTU/H, Wall-Mounted Heat Pump System

Job Name:	Location:		
Purchaser:	Submitted by:		
Submitted to:	Reference:	Approval:	Construction:
Engineer:	Date:	Application:	

- 1\ENERGY STAR certified + Xtreme Heat, up to 94% Heating at 5°F
- 2\WiFi built-in, Available ConnectLife APP for both iOS and Android to control your room temp. with smartphone
- 3\Anti corrosion heat exchanger for Hesse-WiFi built-in, Available operation
- 4\Universal indoor units with Hi-Multi
- 5\Heating below -20°C (-4°F)
- 6\Chassis Electric heater
- 7\ Easy installation
- 8\ "I feel" in remote controller
- 9\ 2 -Way Drain Connection (Left or Right)
- 10\Washable High Definition Filter
- 11\ Auto Restart
- 12\Indoor Self-Cleaning w/ FrostClean Technology
- 13\Optional Wired Controller



Images provided for reference purposes only

Performance:

Cooling	Cooling Capacity	Btu/h	24000
	Cooling Capacity Range	Btu/h	5500~25000
	Rated Input-Cooling	W	1920
Heating at 47°F	Heating Capacity	Btu/h	26000
	Heating Capacity Range	Btu/h	6000~27000
	Rated Input-Heating	W	2,500
Heating at -8.3 °C (17°F AHRI)	Heating Capacity	Btu/h	15,500
Heating at -15 °C (5 °F)	Heating Capacity	Btu/h	18,200
Heating at -20 °C (-5 °F)	Heating Capacity	Btu/h	17,500
Heating at -25 °C (-13 °F)	Heating Capacity	Btu/h	16,800
Heating at -30 °C (-22 °F)	Heating Capacity	Btu/h	15,000

Efficiency:

SEER	21
SEER2	21
HSPF	11.50
HSPF2	10
EER -BTU/W	12.5
COP -BTU/W	10.41

Outdoor Operating Temperature Range:

Working Temperature Range - Cooling	(°C/°F)	-15°C~46°C ; (5°F~115°F)
Working Temperature Range - Heating	(°C/°F)	-30°C~24°C ; (-22°F~75°F)

Electrical:

Power Supply	208-230V~ 60Hz, 1Ph	
Rated Current	Cooling (A)	8.5
	Heating (A)	11
Current Range	Cooling (A)	1.8-13
	Heating (A)	1.8-13
Max Fuse Size/Fusible Max.	A	30
Min.Circuit Ampacity	A	20



Submittal Data: AS-24UW3SKKVT00 AS-24UW3SKKVT00G
24,000 BTU/H, Wall-Mounted Heat Pump System

Indoor Unit Specifications:

Fan Motor Output	W	50
Fan Motor Speed (H/M/L)	RPM	1150/1000/850
Moisture Removal	L/H.r	2.4
Air Circulation (Ultra\High\Medium\Low)	m3/h	1200 / 1100 / 950
Sound Pressure(Higer/H/M/L/silence)	dB (A)	53/50/47/45/42
Net Dimensions WxHxD	mm	1286×346×262
	in.	50 3/8x14 3/16x10 1/4
Net Weight	kg	18.2
	lbs.	40.1

Outdoor Unit Specifications:

Fan Motor Output	W	70
Fan Motor Speed (H/M/L)	RPM	840
Sound pressure	dB (A)	61
Refrigerant charge volume	g	R410A/2100
Net Dimensions WxHxD	mm	900x750x340
	in.	35 3/8x29 1/2x13 1/2
Net Weight	kg	60
	lbs.	132.3
Liquid Pipe	in.	3/8
Gas Pipe	in.	5/8
Maximum Piping Length	m.	20
Maximum Height Difference	m.	10

Model No.	Description:
RCH-RTY5-0	Remote Controller
YXE-C01U1	Wired Controller (Optional)

Indoor Unit Outline and Dimensions:

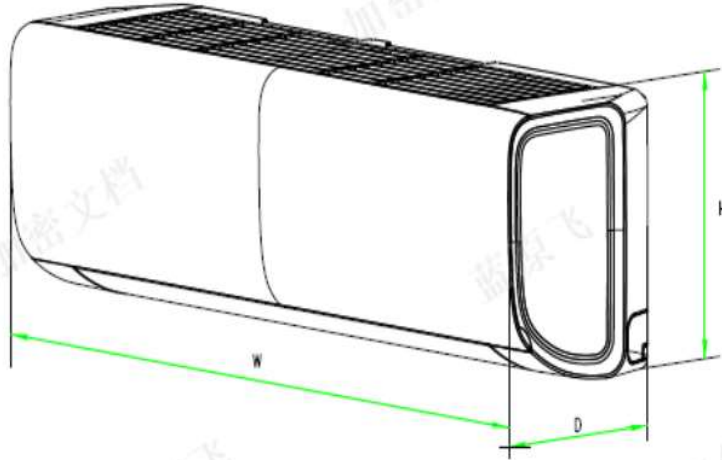

	W	H	D
mm	1286	346	262
in	50.6	13.6	10.3

Outdoor Unit Outline and Dimensions:

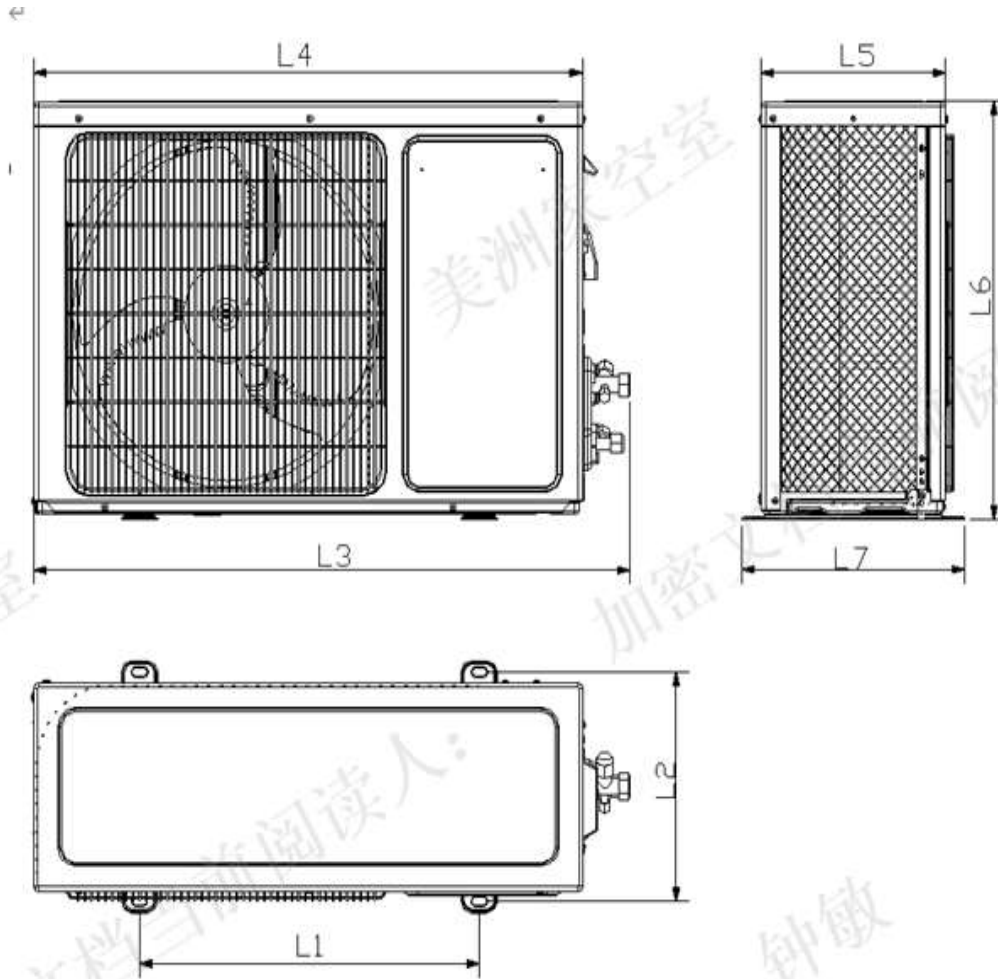

	L1	L2	L3	L4	L5	L6	L7
mm	608	386	974	900	340	750	398
in	23.94	15.20	38.35	35.43	13.39	29.53	15.67