

Project Name:	
Location:	
Engineer:	
Submitted to:	
Submitted by:	
Reference:	

Approval:	
Date:	
Construction:	
Unit #:	
Drawing #:	

Description:
Hi-Uni, Single Zone, 18,000 BTU Duct Type, Heat Pump



Indoor Unit Model:
 ADT-09UX3SBL
 ADT-12UX3SBL



Indoor Unit Model:
 ADT-24UX3SLM
 AUD-36UX3SHH1



ADT-18UX3SCL

KEY FEATURES

Indoor Unit Features

- ❑ Universal indoor unit for both single-zone and multi-zones
- ❑ Self diagnostic and error code display
- ❑ Quiet operation down to 36 dBA sound pressure level
- ❑ Slim Cabinet, with 190mm thickness
- ❑ Built-in drain pump with 47.2" lift
- ❑ Multiple control options available:
- ❑ Control:
 - ❖ Standard with Wired control YXE-C01U1(E)
 - ❖ Optional Remote controller
 - ❖ Connect Life smart device app for remote access (Separate module needed)

Technical Spec.

Model	ADT-18UX3SFCL
Indoor unit model	ADT-18UX3SCL
Outdoor unit model	AUW-18U3SF

<u>Indoor Model Number</u>		ADT-09UX3SBL	ADT-12UX3SBL	ADT-18UX3SCL	ADT-24UX3SLM	AUD-36UX3SHH1
Indoor fan motor						
-						
Model		SIC-68CVL-F140-1	SIC-68CVL-F140-1	SIC-68CVL-F160-2	SIC-70CW-F195-1	SIC-101CW-F1250-4
Type		DC	DC	DC	DC	DC
Input		40	40	60	95	250
RLA	A	0.25	0.25	0.33	0.5	1
LRA	A	---	---	---	---	---
Winding Resistance	Ω	---	---	---	---	---
Capacitor	μ F	---	---	---	---	---
Speed(Hi/Mi/Lo)	r/min	690/590/510	790/690/590	860/760/660	1010/890/780	850/700/600
Air flow & Noise level						
Indoor air flow (Hi/Lo)	CFM	309/259/208	324/285/235	529/441/371	706/588/500	883/735/617
Indoor noise level (Hi/Lo)	dB(A)	35/33/32	36/34/33	38/37/36	42/38/36	43/40/38
Indoor unit						
-						
Dimension(W*H*D)	inch	35-7/8x7-1/2x17-5/8	35-7/8x7-1/2x17-5/8	46-1/2x7-1/2x17-5/8	35-3/8x10-5/8x28-3/8	51-1/8x13-3/4x31-1/2
Packing (W*H*D)	inch	42-1/2x11-1/4x22-1/4	42-1/2x11-1/4x22-1/4	53-1/8x11-1/4x22-1/4	46-1/8x13-3/8x34-1/4	61x16-1/8x37
Net/Gross weight	lbs.	39.7/46.3	39.7/46.3	49.6/57.3	66.1/77.2	112.4/132.3

ESP. Chart

Indoor Unit Model: ADT-09UX3SBL

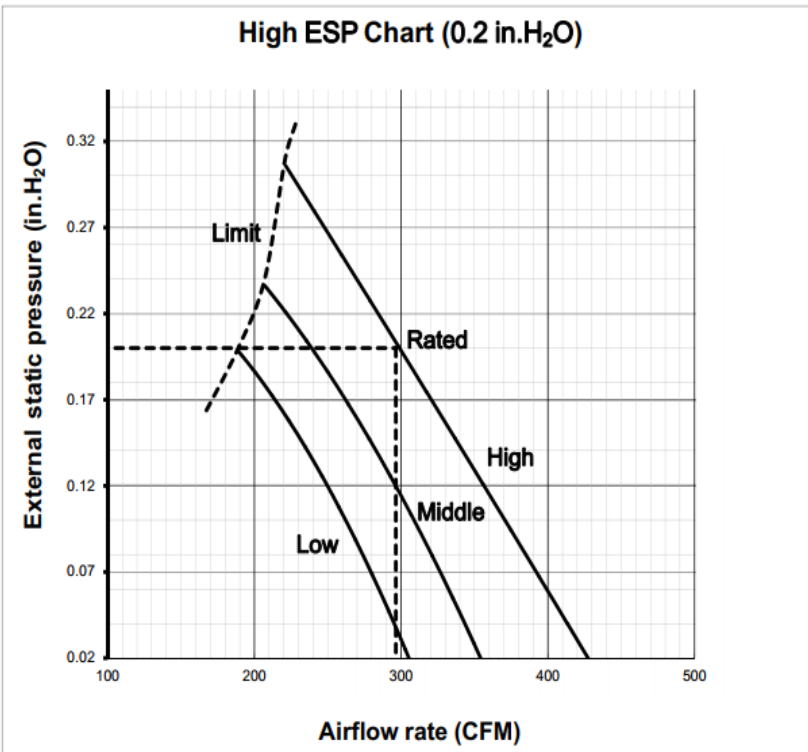
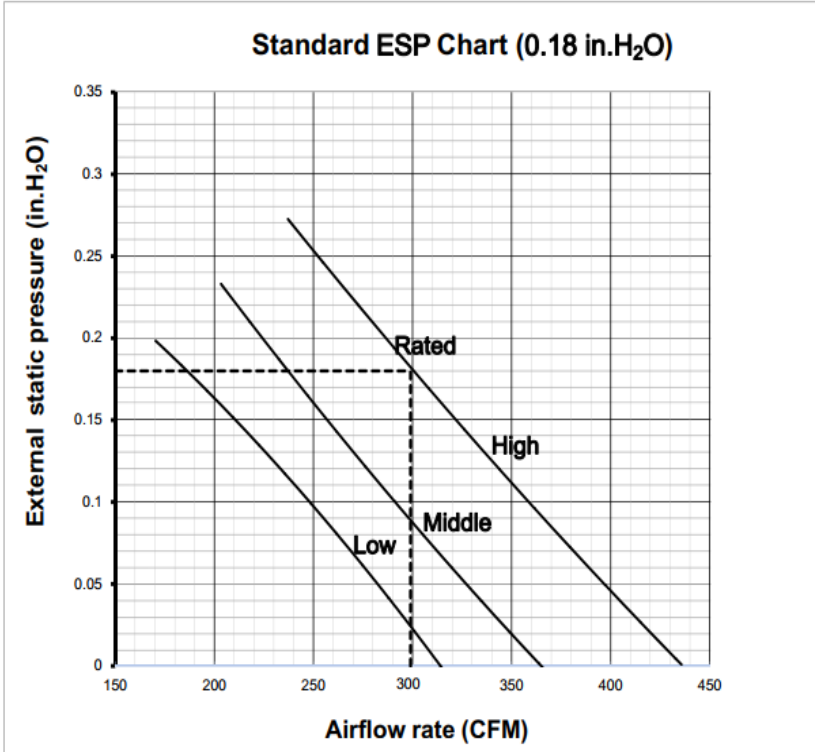

ESP. Chart

Indoor Unit Model: ADT-12UX3SBL

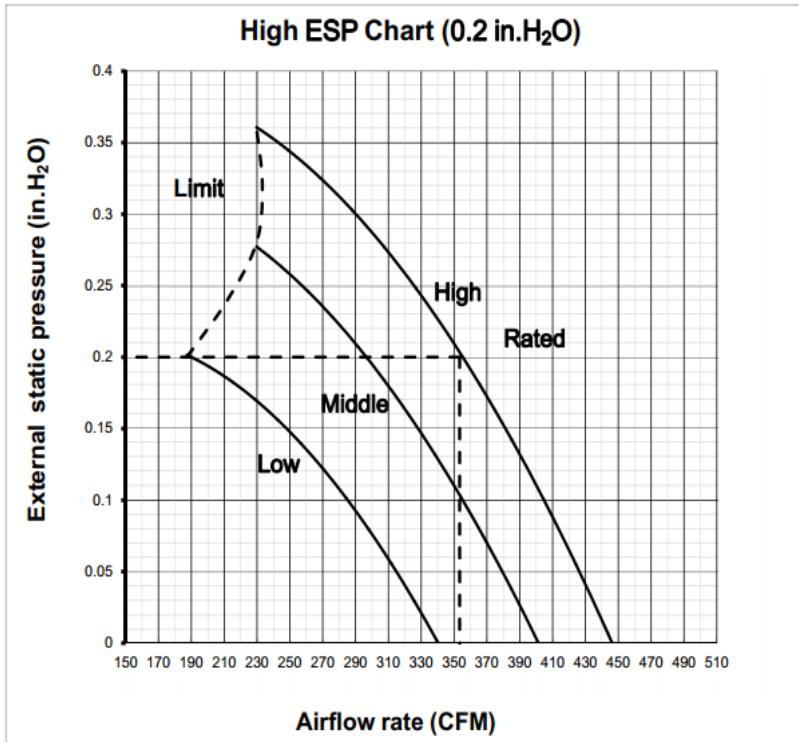
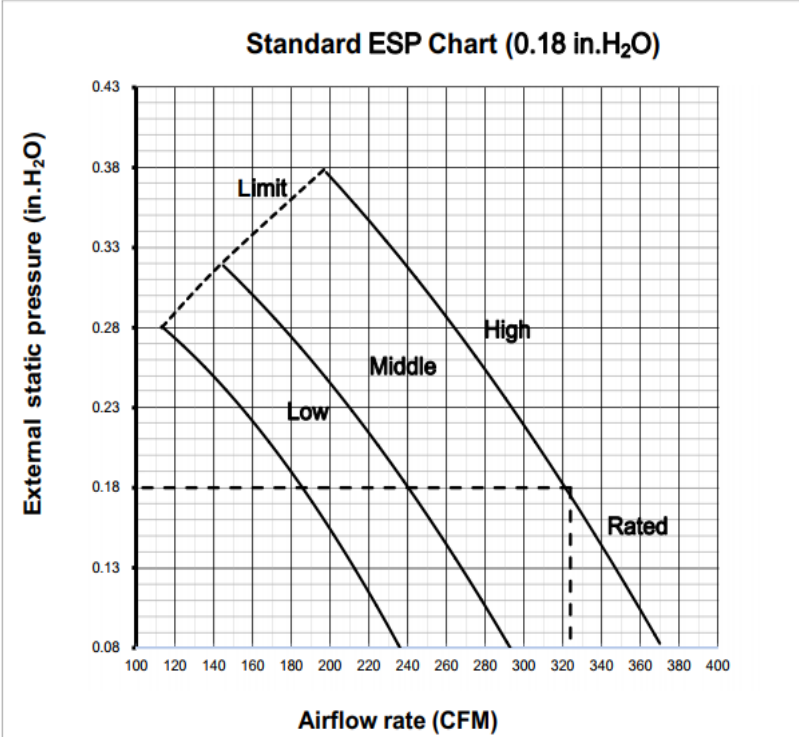

ESP. Chart

Indoor Unit Model: ADT-18UX3SCL

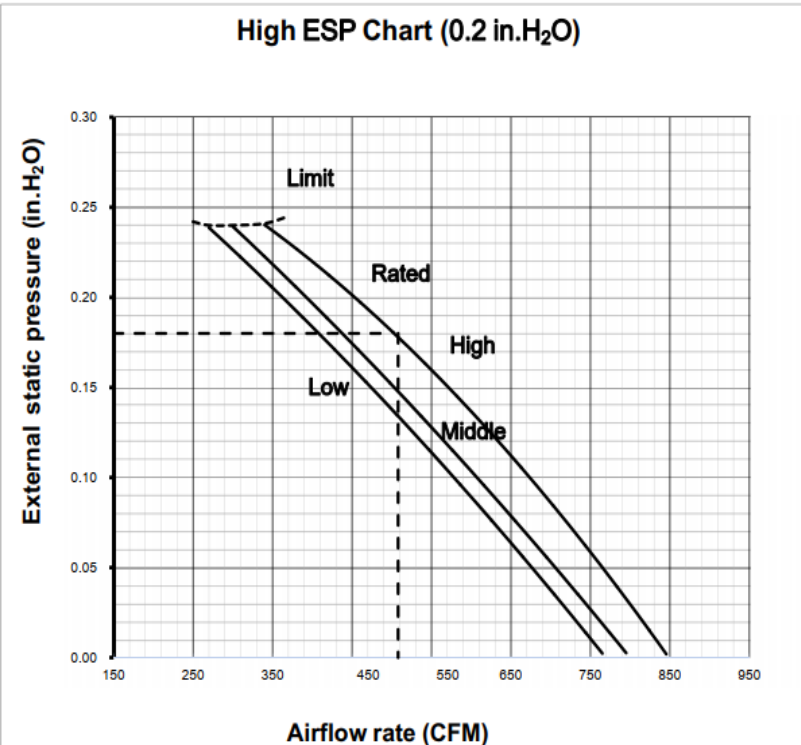
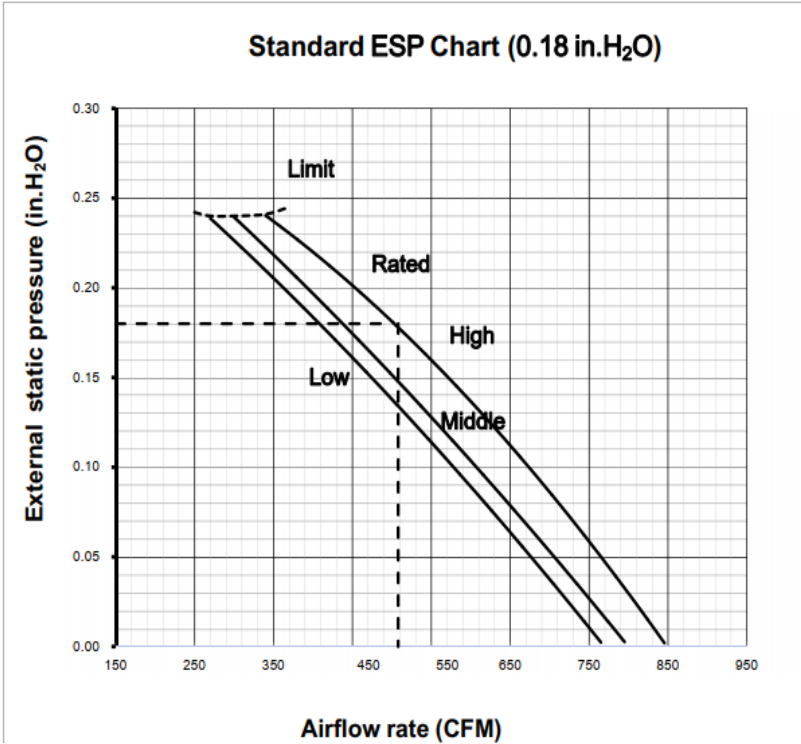

ESP. Chart

Indoor Unit Model: ADT-24UX3SLM

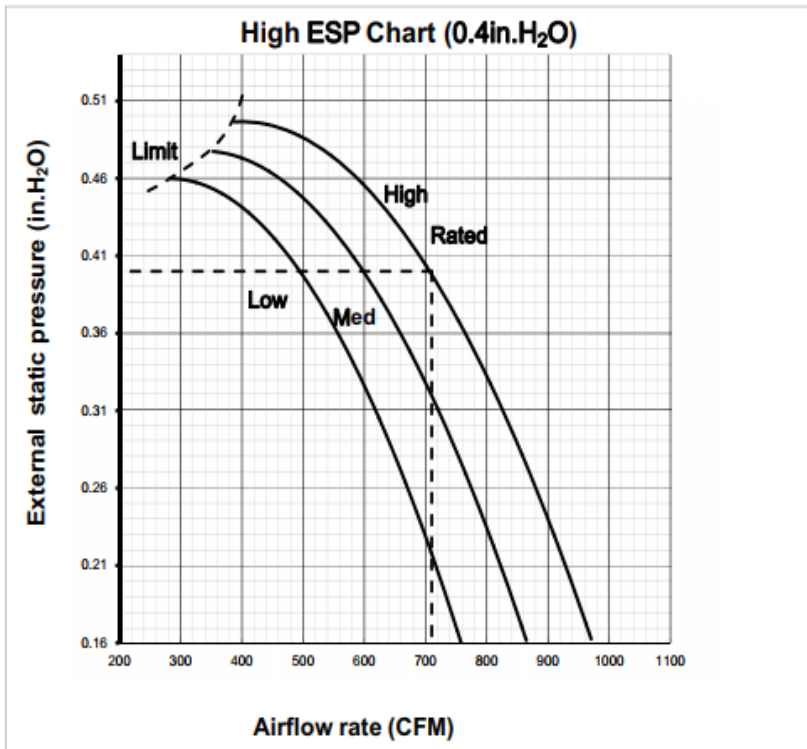
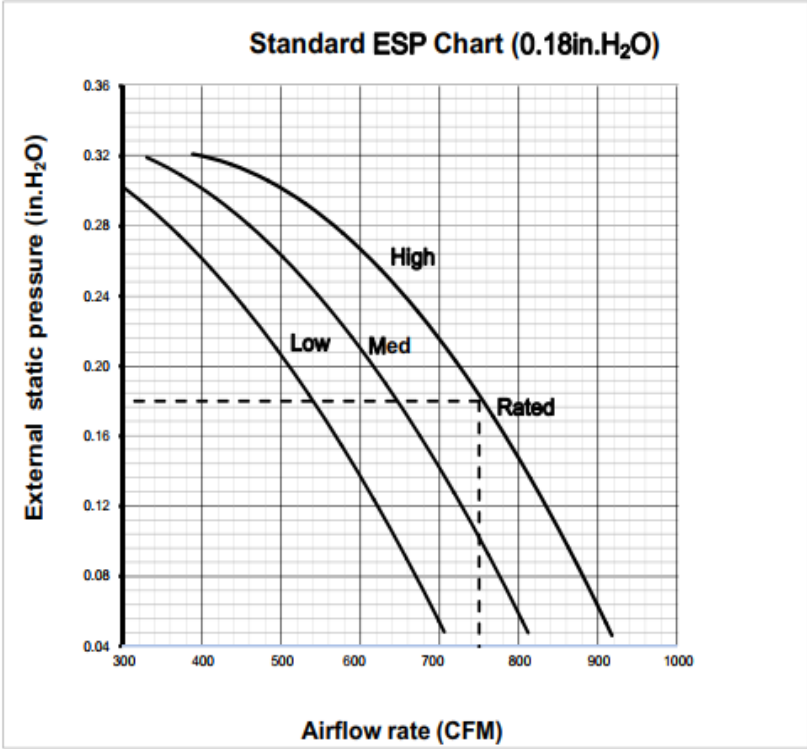

ESP. Chart

Indoor Unit Model: AUD-36UX3SHH1

36K

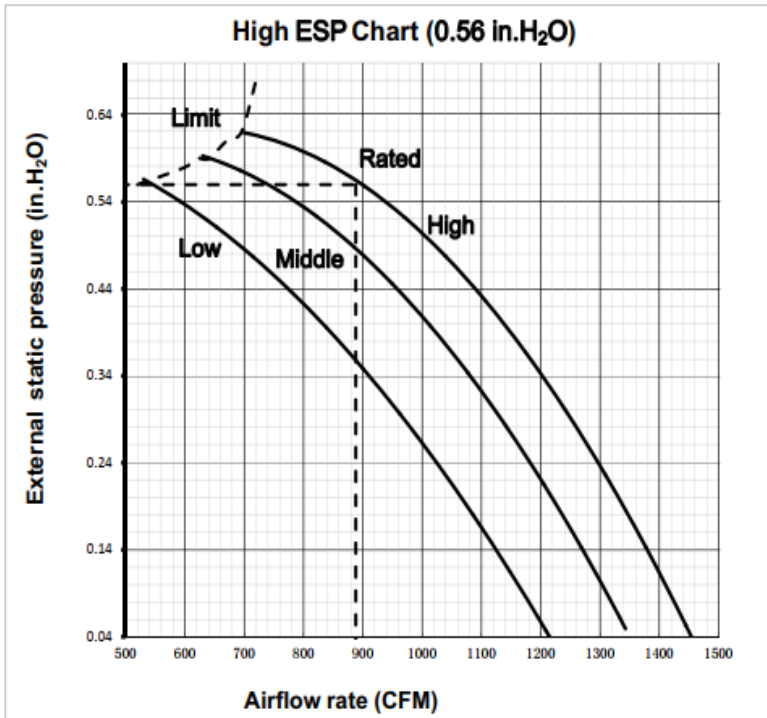
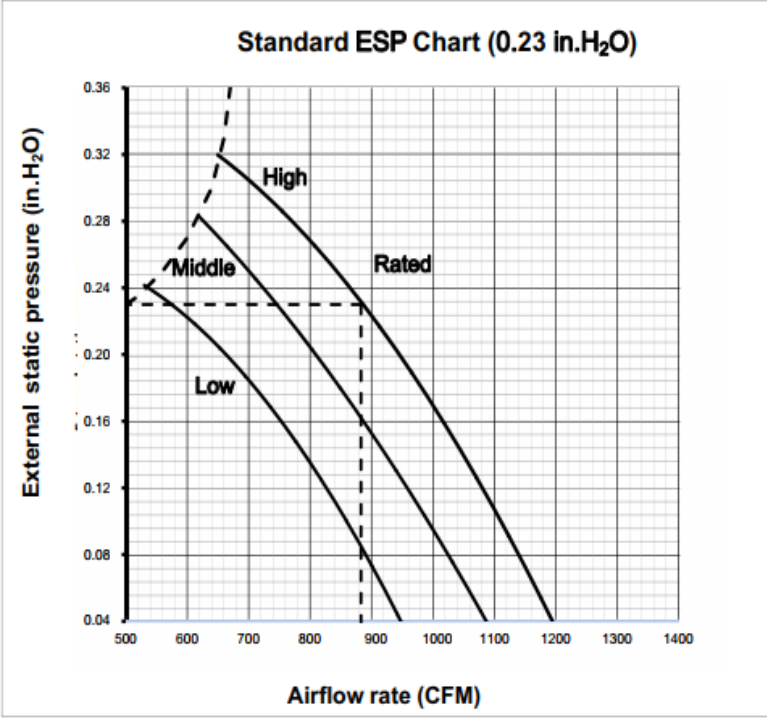

DIMENSIONAL DRAWING
Duct

Indoor Unit Model:

- ADT-09UX3SBL
- ADT-12UX3SBL
- ADT-18UX3SCL

Unit: inch(mm)

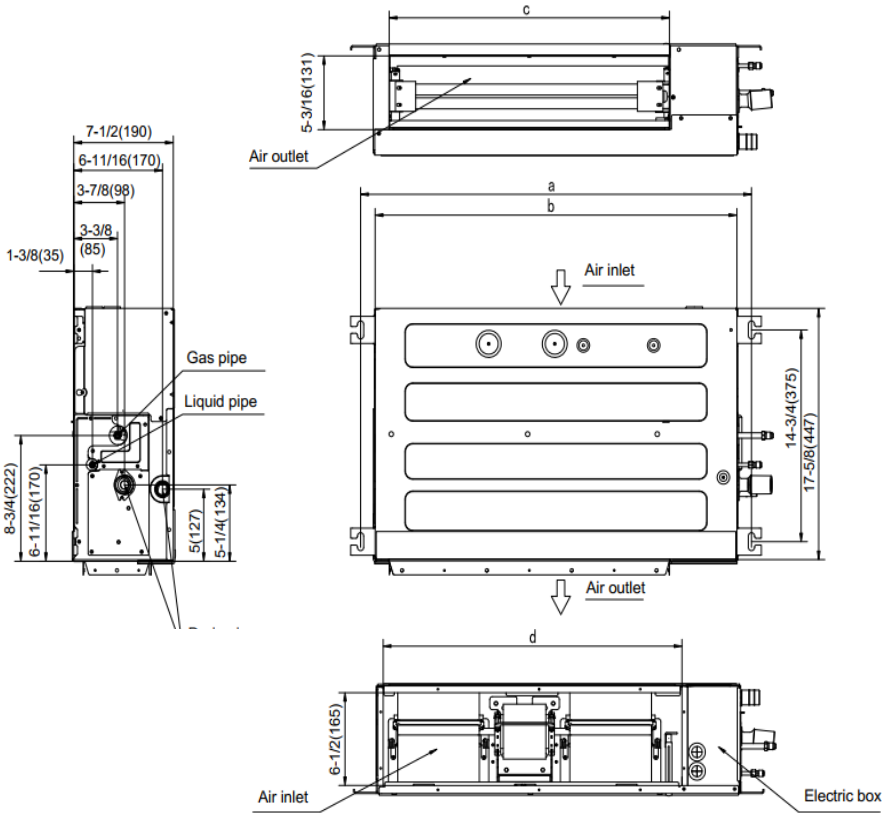

Model (Btu/h)	a	b	c	d
9K/12K	37-13/16 (961)	35-13/16 (910)	29-1/2 (749)	30 (786)
18K	48-7/16 (1231)	46-7/16 (1180)	40-1/8 (1019)	41-5/8 (1056)

DIMENSIONAL DRAWING Duct

Indoor Unit Model: ADT-24UX3SLM, AUD-36UX3SHH1

Unit: inch(mm)

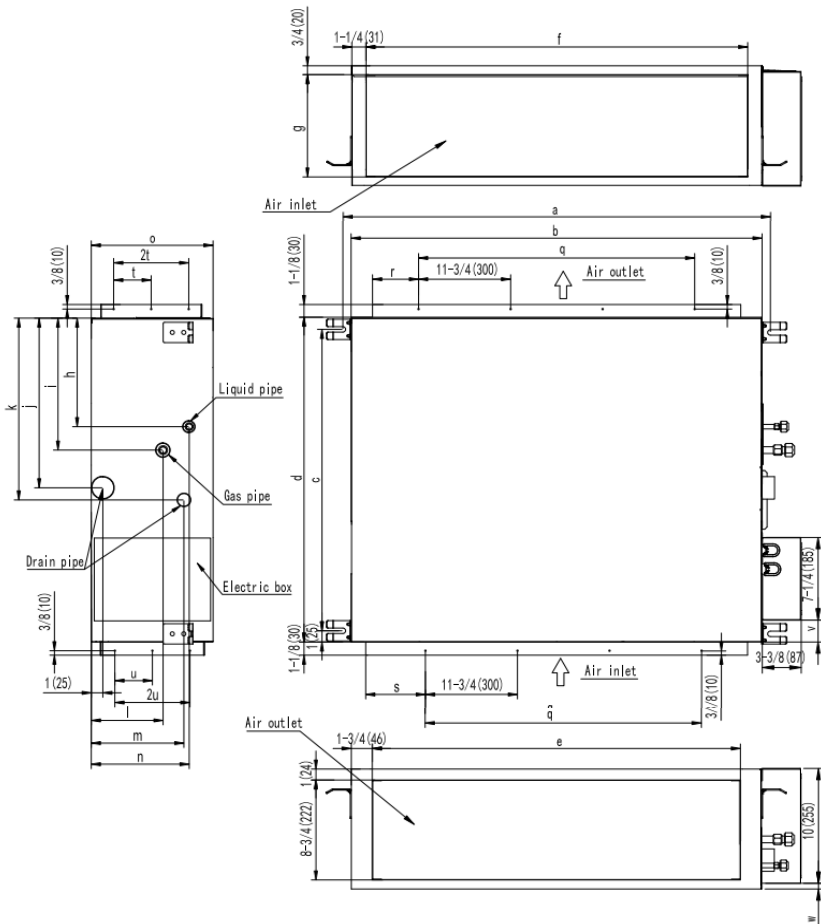

Model	a	b	c	d	e	f	g	h	i	j	k	l	m	n	o	q	r	s	t	u	v	w
24K	36-3/4 (934)	35-3/8 (900)	26-3/8 (669)	28-3/8 (720)	31-3/4 (805)	32-7/8 (835)	9 (228)	9-1/2 (242)	11-5/8 (294)	14-7/8 (378)	16 (405)	6-1/8 (156)	8 (202)	8-3/8 (214)	10-5/8 (270)	23-5/8 (600)	4 (102)	4-5/8 (117)	3-1/4 (82)	3-1/4 (82)	1-7/8 (49)	1/4 (5)
36K	52-1/2 (1334)	51-1/8 (1300)	29-3/4 (756)	31-1/2 (800)	47-1/2 (1205)	48-5/8 (1235)	12-1/8 (308)	9-3/8 (237)	12-3/8 (312)	14-3/4 (375)	15-3/4 (400)	8 (204)	7-3/8 (186)	9-1/2 (242)	13-3/4 (350)	35-3/8 (900)	6 (153)	6-5/8 (168)	3-1/2 (90)	5-1/2 (140)	4-3/8 (110)	1-7/8 (49)