

TECHNICAL & SERVICE MANUAL V4.0

—DC-INVERTER AIR CONDITIONERS

Models:

<Indoor Units>

Duct

AMD-09UX3SBL
AMD-12UX3SBL
AMD-18UX3SBL
ADT-09UX3SBL
ADT-12UX3SBL
ADT-18UX3SCL
ADT-24UX3SLM
AUD-36UX3SHH1

Cassette

AMC-09UR3SRCA
AMC-12UR3SRCA
AMC-18UR3SGB
ACT-09UR3SCA
ACT-12UR3SCA
ACT-18UR3SGB
ACT-24UR3SGB
AUC-36UR3SHB1

<Outdoor Units>

AUW-09U3SS
AUW-12U3SS
AUW-18U3SF
AUW-24U3SA
AUW-36U3ST1

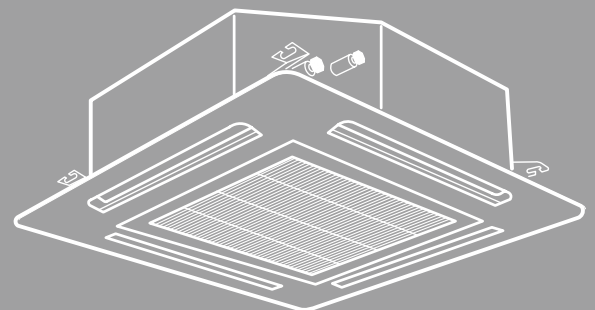
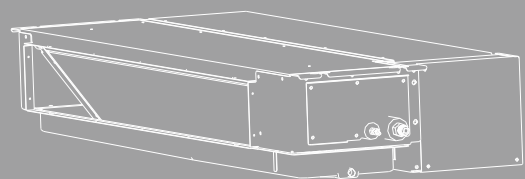
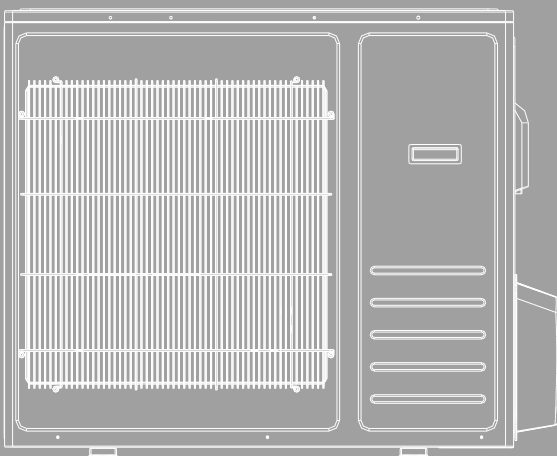

SAFETY SUMMARY

IMPORTANT NOTICE

- We pursue a policy of continuing improvement in design and performance of products. The right is therefore reserved to vary specifications without notice.
- We cannot anticipate every possible circumstance that might involve a potential hazard.
- This air conditioner is designed for standard air conditioning only. Do not use this air conditioner for other purposes such as drying clothes, refrigerating foods or for any other cooling or heating process. Do not let the air-out face animals or plants, it might have an adverse effect on it.
- The installer and system specialist shall secure safety against leakage according to local regulations or standards.
- Signal words (DANGER, WARNING and CAUTION) are used to identify levels of hazard seriousness. Definitions for identifying hazard levels are provided below with their respective signal words.

▲ DANGER

: Immediate hazards which WILL result in severe personal injury or death.

▲ WARNING

: Hazards or unsafe practices which COULD result in severe personal injury or death.

▲ CAUTION

: Hazards or unsafe practices which COULD result in minor personal injury or product or property damage.

NOTE

: Useful information for operation and/or maintenance.

- Installation should be performed by the dealer or another professional personnel. Improper installation may cause water leakage, electrical shock, or fire.

▲ DANGER

- Do not perform installation work, refrigerant piping work, drain piping and electrical wiring connection without referring to our installation manual. If the instructions are not followed, it may result in a water leakage, electric shock or a fire.
- Use refrigerant R410A in the refrigerant cycle.
- Do not pour water into the indoor or outdoor unit. These products are equipped with electrical parts. If poured, it will cause a serious electrical shock.
- Do not open the service cover or access panel for the indoor or outdoor units without turning OFF the main power supply.
- Do not touch or adjust safety devices inside the indoor or outdoor units. If these devices are touched or readjusted, it may cause a serious accident.
- Refrigerant leakage can cause difficulty with breathing due to insufficient air. Turn OFF the main switch, extinguish any naked flames and contact your service contractor, if refrigerant leakage occurs.
- Do perform air-tight test. Do not charge oxygen, acetylene or other flammable and poisonous gases into the refrigerant cycle when performing a leakage test or an air-tight test. These types of gases are extremely dangerous and can cause an explosion. It is recommended that nitrogen be used for this test.
- The installer and system specialist shall secure safety against refrigerant leakage according to local regulations or standards.
- Use an ELB (Electric Leakage Breaker). In the event of a fault, there is danger of an electric shock or a fire if it is not used.

▲ WARNING

- Do not use any sprays such as insecticide, lacquer, hair spray or other flammable gases within approximately one (1) meter from the system.

- If circuit breaker or fuse is often activated, stop the system and contact your service contractor.
- Check that the ground wire is securely connected. If the unit is not correctly grounded, it will lead to electric shock. Do not connect the ground wiring to gas piping, water piping, lightning conductor or ground wiring for telephone.
- Before performing any brazing work, check to ensure that there is no flammable material around when using refrigerant. Be sure to wear leather gloves to prevent cold injuries.
- Protect the wires, electrical parts, etc. from rats or other small animals.
If not protected, rats may gnaw at unprotected parts, which may lead to fire.
- Fix the cables securely. External forces on the terminals could lead to a fire.
- Install the air conditioner on a solid base that can support the unit weight. An inadequate base or incomplete installation may cause injury in the event the unit falls off the base. Incomplete connections or clamping may cause terminal overheating or fire.
- Make sure that the outdoor unit is not covered with snow or ice, before operation.

⚠ CAUTION

- Do not step or put any material on the product.
- Do not put any foreign material on the unit or inside the unit.

NOTE

- It is recommended that the room be ventilated every 3 to 4 hours.
- The air conditioner may not work properly under the following circumstances.
The power transformer provides the same power or power as the air conditioner. The electrical equipment is too close to the power supply of the air conditioner. With the sharp change of power consumption and switching action, the power supply of the air conditioner will generate a large induction surge voltage.

CHECKING PRODUCT RECEIVED

- Upon receiving this product, inspect it for any shipping damage. Claims for damage, either apparent or concealed, should be filed immediately with the shipping company.
- Check the model number, electrical characteristics (power supply, voltage and frequency) and accessories to determine if they are correct.
The standard utilization of the unit shall be explained in these instructions.
Therefore, the utilization of the unit other than those indicated in these instructions is not recommended.
Please contact your local agent, as the occasion arises.

☑ • *The figures in this manual are based on the external view of a standard model. Consequently, the shape may differ from that of the air conditioner you have selected.*

Table of Contents

1. General	1
1.1 Features	1
1.2 Product lineup	3
1.3 Nomenclature	3
1.4 Unit installation	4
1.5 Working range	4
1.6 Product appearance	5
2. Specifications	8
2.1 Duct type	8
2.2 Cassette type	11
3. Outlines and dimensions	14
3.1 Indoor units	14
3.2 Outdoor units	18
4. Electrical data	22
5. Capacities and selection data	23
5.1 Capacity characteristic charts	23
5.2 Piping length correction factor	34
5.3 Correction factors according to defrosting operation	36
6. Sound pressure data	37
7. Air flow distribution	42
8. ESP (External static pressure) chart (Duct type)	46
9. Refrigerant cycle	51
10. Fresh air intake function	55
11. Wiring diagram	56
11.1 Electrical wiring diagrams	56
11.2 Control board picture	62
11.3 Common wiring	69
12. Field setting	70
12.1 Outdoor unit DIP switch	70
12.2 ESP setting	71
12.3 Indoor unit parameter revision	72
12.4 Running parameter query	74
12.5 Instructions for the function setting of access control	77
12.6 Instructions for the function setting of ON/OFF	79
13. Piping work and refrigerant charge	80
13.1 MAX. length allowed	80
13.2 Oil trap	80
13.3 Air tight test	81
13.4 Additional refrigerant charge	81
14. Installation tools and installation flow chart	82
14.1 Necessary tools and instrument list for installation	82
14.2 Installation flow chart	83
15. Control mode	84
15.1 Indoor unit mode control	84
15.2 Outdoor unit mode control	87
16. Sensor parameter	88
17. Troubleshooting	94
17.1 Trouble guide	94
17.2 Fault codes	99
18. Checking components	108
18.1 Check refrigerant system	108
18.2 Check parts unit	110
19. Disassembly and assembly for compressor and motor	113
20. Control logic description	124

1. GENERAL

1. General

1.1 Features

Duct Type Air Conditioner

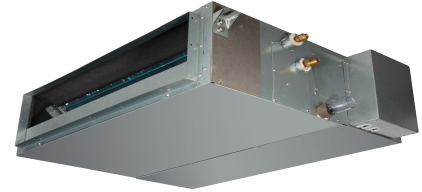
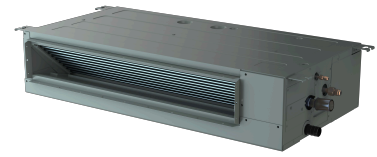

Features

- **Saving Installation Space**

The indoor unit can be installed inside the ceiling conveniently.
- **Optional Static Pressure**

Optional ESP, a variety of optional installation methods.
- **24-hour Timer ON and OFF**

This Timer can be set to automatically turn the unit on or off within a 24-hour period.
- **Mute Operation**

The excellent fan design enables smooth airflow with minimum noise.
- **Meeting Various Installation Requirements**

The back-air-inlet type should be adopted according to the actual installation space. The unit is also installed with down-air-inlet type and the noise will increase by 5-6dB.
- **Auto Re-start from Power Break**

When the power supply is recovered after power break, all presets are still effective and the air-conditioner will run according to the previous setting.
- **Fault Self-diagnosis Function**

When there is a problem in the air-conditioner, the microcomputer could diagnose the faults, which can be read from the display and is convenient for maintenance.

1. GENERAL

Cassette Type Air Conditioner



Features

- **Saving Installation Space**
The indoor unit can be installed inside the ceiling conveniently.
- **24-hour Timer ON and OFF**
This Timer can be set to automatically turn the unit on or off within a 24-hour period.
- **Mute Operation**
The excellent fan design enables smooth airflow with minimum noise.
- **Auto re-start from Power Break**
When the power supply is recovered after power break, all presets are still effective and the air-conditioner will run according to the previous setting.
- **Fault Self-diagnosis Function**
When there is a problem in the air-conditioner, the microcomputer can diagnose the faults, which can be read from the display and is convenient for maintenance.

1. GENERAL

1.2 Product lineup

Model (Btu/h) Type	9K	12K	18K	24K	36K
Duct	●	●	●	●	●
Cassette	●	●	●	●	●

●: available model
○: in development

1.3 Nomenclature

A U D - 36 U X 3 S T H H

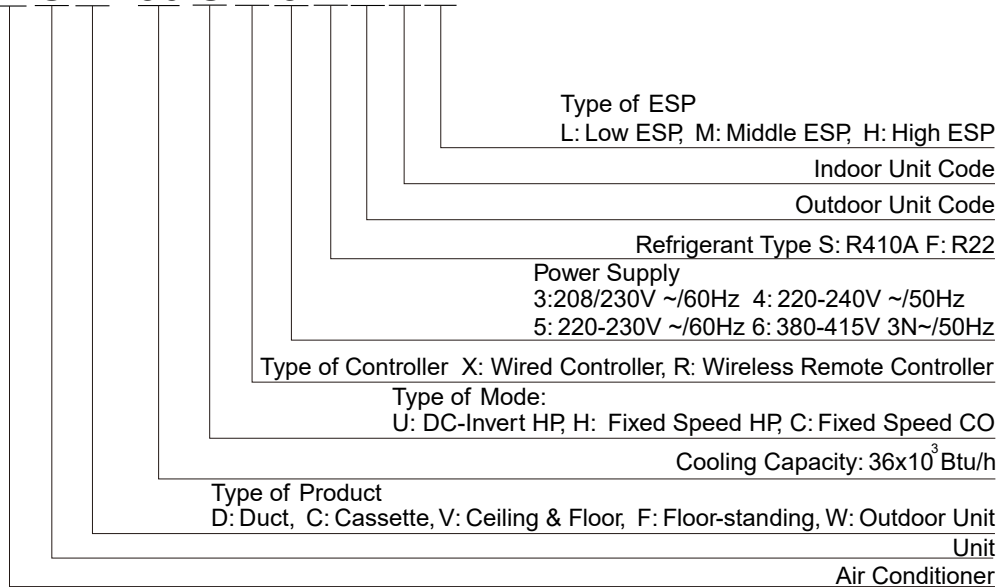

1. GENERAL

1.4 Unit installation

1:1 system is the only compatible combination.

(Only one indoor unit can be connected with one outdoor unit.)

1.5 Working range

Power Supply

Working Voltage	9K/12K/18K: 198V ~ 253V 24K/36K: 176V ~ 253V
Voltage Imbalance	Within a 3% deviation from each voltage at the main terminal of outdoor unit
Starting Voltage	Higher than 85% of the Rated Voltage

Operating temperature range

This air conditioner is designed for the following outdoor operating temperatures.

Type	Mode	Outdoor operating temperature [°F(°C)]	
		maximum	minimum
DC-Inverter Split Air Conditioner	Cooling Operation	118(48)	5(-15)
	Heating Operation	75(24)	-4(-20)

Storage condition: Temperature: -13~140°F (-25~60°C)
Humidity: 30%~80%

1. GENERAL

1.6 Product appearance

Duct type

Model (Btu/h)	Indoor Unit	Outdoor Unit
9K/12K		
18K		
24K		
36K		

1. GENERAL

Cassette type

Model (Btu/h)	Indoor Unit	Outdoor Unit
9K/12K		
18K		
24K		
36K		

1. GENERAL

Display panel

Duct Type

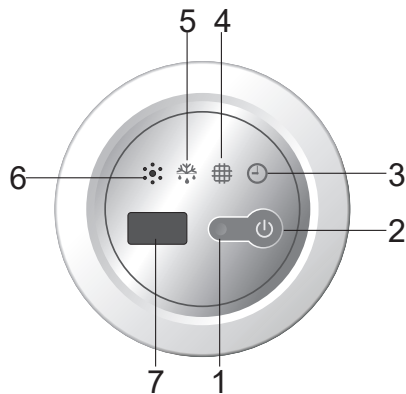

Cassette Type

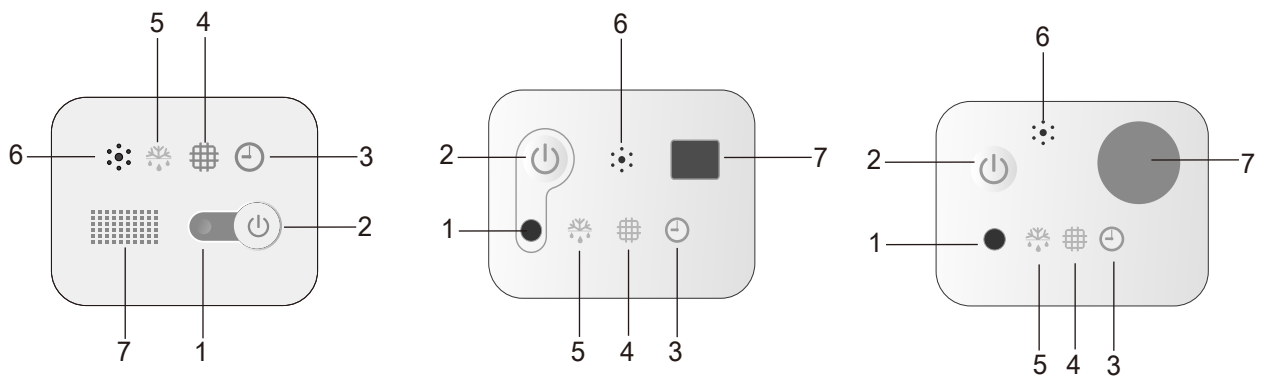

Description

1 Run indicator (Red)

It lights up in operation. It stops lighting in SLEEP mode.

2 Emergency switch

The filter cleaning indicator is reset when the switch is pressed. The unit will be started or stopped once the switch is pressed. The unit will be operated in forced cooling mode if the switch is pressed continuously for more than 5s when the unit is off.

3 Timer indicator (Green)

It lights up when timer is in use. It lights off when timer stops working.

4 Filter cleaning (Yellow)

It lights up when the filter needs to be cleaned.

5 Defrosting indicator (Green)

It lights up during defrosting and it stops lighting when defrosting is completed.

6 Buzzer

It rings when the signal from remote controller is received.

7 Infrared receiver

It receives signal from the remote controller.

2. SPECIFICATIONS

2. Specifications

2.1 Ducted

Model		ADT-09UX3SSBL	ADT-12UX3SSBL	ADT-18UX3SFCL	ADT-24UX3SALM	AUD-36UX3STHH1	
Indoor Model		ADT-09UX3SBL	ADT-12UX3SBL	ADT-18UX3SCL	ADT-24UX3SLM	AUD-36UX3SHH1	
Outdoor Model		AUW-09U3SS	AUW-12U3SS	AUW-18U3SF	AUW-24U3SA	AUW-36U3ST1	
E-STAR_V6.1		Yes	No	No	No	No	
NEEP		Yes	Yes	Yes	Yes	Yes	
Canada Greener Home Program		Yes	Yes	Yes	Yes	Yes	
Power Supply	V/ph/Hz	208/230/1/60	208/230/1/60	208/230/1/60	208/230/1/60	208/230/1/60	
Energy Star		Yes	No	No	No	No	
Cooling	Rated Capacity	Btu/h	9000	12000	18000	24000	36000
	Capacity(MIN-MAX)	Btu/h	4850-11600	5800-13100	4200-21000	8500-27000	12500-37300
	Input	W	750	1091	1580	2300	3300
	Current	A	3.5	5	7.3	10.5	15.1
	EER2	W/W	3.52	3.22	3.34	3.06	3.20
	SEER2	Btu/h/W	12.00	11.00	11.40	10.45	10.90
Heating	Rated Capacity	Btu/h	10000	12000	17500	26000	36000
	Capacity(MIN-MAX)	Btu/h	4340-12280	4400-14400	5600-24000	7600-28400	15000-39800
	Input	W	825	1091	1465	2460	3500
	Current	A	3.8	5	6.9	11.2	15.9
	COP2	W/W	3.55	3.22	3.50	3.10	3.01
	COP2	Btu/h/W	12.12	11.00	11.94	10.58	10.29
	HSPF2	Btu/h/W	9	9	9.5	9.5	9.5
	Rated Capacity Heating at 17°F	Btu/h	6500	7800	13000	19300	28400
	Maximum Heating Capacity @5F	Btu/h	7100	8900	12300	19000	27400
	COP @ 5F (Under Maximum Capacity)	W/W	2.10	2.00	2.10	2.02	2.20
Working Temperature Range	Cooling	°F	5-118	5-118	5-118	5-118	5-118
		°C	-15-48	-15-48	-15-48	-15-48	-15-48
	Heating	°F	-4-75	-4-75	-4-75	-13-75	-4-75
		°C	-20 - 24	-20 - 24	-20 - 24	-25 - 24	-20 - 24
Indoor Noise Level (Sound Pressure Hi/Med/Lo)		dB(A)	35/33/32	36/34/33	38/37/36	42/38/36	43/40/38
Outdoor Noise Level (Sound Pressure)		dB(A)	52	52	55	55	61
ESP	Rated	Pa	25	25	25	45	57
		in-H ₂ O	0.1	0.1	0.1	0.18	0.23
	Range	Pa	0-50	0~50	0~50	0~100	0~140
		in-H ₂ O	0-0.2	0-0.2	0-0.2	0-0.4	0-0.56
Design Pressure	H/L	MPa	3.8/1.6	3.8/1.6	3.8/1.6	3.8/1.6	3.8/1.6
	H/L	PSIG	550/240	550/240	550/240	550/240	550/240
Drainage Water Pipe Diameter		mm/in	dΦ32/(1-1/4)	dΦ32/(1-1/4)	dΦ32/(1-1/4)	dΦ32/(1-1/4)	dΦ32/(1-1/4)
ELECTRICAL DATA							
MIN. AMPACITY		A	7.3	12	15	23	25
MAX. TD FUSE/ BREAKER		A	15	20	20	35	45
Power and Communication Cable		No.x AWG	3x12/4x16	3x14/4x16	3x12/4x16	3x12/4x16	3x10/4x16
Remote Control Adjustable Temperature Range		°C	16 - 30	16-30	16-30	16 - 30	16-30
		°F	61-86	61-86	61-86	61-86	61-86
AIR SUPPLY SYSTEM							
Indoor Fan Motor	Model		SIC-68CVL-F140-1	SIC-68CVL-F140-1	SIC-68CVL-F160-2	SIC-70CW-F195-1	SIC-101CW-F1250-4
	Qty		1	1	1	1	1

2. SPECIFICATIONS

Model			ADT-09UX3SSBL	ADT-12UX3SSBL	ADT-18UX3SFCL	ADT-24UX3SALM	AUD-36UX3STHH1
Indoor Model			ADT-09UX3SBL	ADT-12UX3SBL	ADT-18UX3SCL	ADT-24UX3SLM	AUD-36UX3SHH1
Outdoor Model			AUW-09U3SS	AUW-12U3SS	AUW-18U3SF	AUW-24U3SA	AUW-36U3ST1
	Output	W	40	40	60	95	250
	Capacitor	μF	NA	NA	NA	NA	NA
	Speed(Hi/Med/Lo)	r/min	690/590/510	790/690/590	860/760/660	1010/890/780	850/700/600
Indoor Air Flow Rated(Hi/Med/Lo)		m ³ /h	520/435/350	550/484/400	900/750/630	1200/1000/850	1500/1250/1050
		CFM	309/259/208	324/285/235	529/441/371	706/588/500	883/735/617
Outdoor Fan Motor	Model		SIC-52FV-F130-3	SIC-52FV-F130-3	ZWK511A805001	SIC-71FW-D8121-1	SIC-81FW-F1138-1
	Qty		1	1	1	1	1
	Output	W	30	30	60	121	138
	Capacitor	μF	NA	NA	NA	NA	NA
	Speed (Hi)	r/min	850	880	880	830	850
Outdoor Air Flow		m ³ /h	2300	2300	3150	3800	5800
		CFM	1354	1354	1854	2237	3414
REFRIGERATION SYSTEM							
Indoor Coil	Number of Rows		3	3	3	3	3
	Tube Pitch(a)	mm	21	21	21	21	21
		in	13/16	13/16	13/16	13/16	13/16
	Row Pitch(b)	mm	13.6	13.6	13.6	13.6	18.19
		in	17/32	17/32	17/32	17/32	23/32
	Fin Spacing	mm	1.6	1.6	1.6	1.6	1.4
		Fins Per in	16	16	16	16	18
	Fin Type		Hydrophilic aluminium	Hydrophilic aluminium	Hydrophilic aluminium	Hydrophilic aluminium	Hydrophilic aluminium
Tube Outside Diameter and Type	mm	Φ7, innergroove tube	Φ7, innergroove tube	Φ7, innergroove tube	Φ7, innergroove tube	Φ7, innergroove tube	
Number of Circuits		6	3	3	4	9	
Outdoor coil	Number of Rows		2	2	2	2	2
	Tube Pitch(a)	mm	21	21	21	21	21
		in	53/64	53/64	53/64	53/64	53/64
	Row Pitch(b)	mm	18.19	21.65	21.65	21.65	21.65
		in	3/4	7/8	7/8	7/8	7/8
	Fin Spacing	mm	1.5	1.5	1.4	1.3	1.6
		Fins Per in	17	17	18	20	16
	Fin Type		Hydrophilic aluminium	Hydrophilic aluminium	Hydrophilic aluminium	Hydrophilic aluminium	Hydrophilic aluminium
Tube Outside Diameter and Type	mm	Φ7, innergroove tube	Φ7, innergroove tube	Φ7.94, innergroove tube	Φ7.94, innergroove tube	Φ7.94, innergroove tube	
Number of Circuits		4	3	3	5	6	
Throttle Type			EEV	EEV	EEV	EEV	EEV
Compressor	Model		ASN108D43UFZ A	ASN108D43UFZ A	ATM150D23UFZ	EATF250D22U MT	ATF310D43UMT
	Type		ROTARY	ROTARY	ROTARY	ROTARY	ROTARY
	Capacity	Btu/h	11090	11090	15422	26085	32380
	Input	W	810	810	1165	2080	2600
	Rated Current(RLA)	A	4.9	8.1	10	16.1	20
	Refrigerant Oil	ml	ESTER OIL VG74/370	ESTER OIL VG74/370	ESTEL OIL VG74/500	VG74 /670	PQE VG74/1000
		oz.	ESTER OIL VG74/12.5	ESTER OIL VG74/370	ESTEL OIL VG74/16.9	VG74 /22.7	PQE VG74/33.8
Refrigerant Type/Quantity	Type		R-410A	R-410A	R-410A	R-410A	R-410A
	Refrigerant Charge	kg	0.95	1.3	1.6	2.6	3.15
		oz.	33.5	45.9	56.44	91.7	111.2
Factory Precharge	Ft.	25	25	25	25	25	

2. SPECIFICATIONS

Model			ADT-09UX3SSBL	ADT-12UX3SSBL	ADT-18UX3SFCL	ADT-24UX3SALM	AUD-36UX3STHH1
Indoor Model			ADT-09UX3SBL	ADT-12UX3SBL	ADT-18UX3SCL	ADT-24UX3SLM	AUD-36UX3SHH1
Outdoor Model			AUW-09U3SS	AUW-12U3SS	AUW-18U3SF	AUW-24U3SA	AUW-36U3ST1
	Additional Charge for Each Ft.	oz.	0.161	0.161	0.161	0.376	0.376
Refrigerant Piping	Liquid Line OD	mm/in	Φ6.35/(1/4)	Φ6.35/(1/4)	Φ6.35(1/4')	Φ9.52(3/8')	Φ9.52(3/8')
	Vapor Line OD	mm/in	Φ9.52(3/8)	Φ9.52(3/8)	Φ12.7(1/2')	Φ15.88(5/8')	Φ19.05(3/4')
	Max. Pipe Length	m	25	25	30	50	50
		Ft.	82	82	98	164	164
	Max. Difference in Level	m	15	15	15	30	30
Ft.		49	49	49	98	98	
DIMENSIONS & WEIGHT							
Indoor Unit	Dimension (W×H×D)	mm	910×190×447	910×190×447	1180×190×447	900×270×720	1300×350×800
		in	35-7/8×7-1/2×17-5/8	35-7/8×7-1/2×17-5/8	46-1/2×7-1/2×17-5/8	35-3/8×10-5/8×28-3/8	51-1/8×13-3/4×31-1/2
	Packing(W×H×D)	mm	1080×285×565	1080×285×565	1350×285×565	1170×340×870	1550×410×940
		in	42-1/2×11-1/4×22-1/4	42-1/2×11-1/4×22-1/4	53-1/8×11-1/4×22-1/4	46-1/8×13-3/8×34-1/4	61×16-1/8×37
	Net Weight	kg	18	18	22.5	30	51
		lbs	39.7	39.7	49.6	66.1	112.4
	Shipping Weight	kg	21	21	26	35	60
		lbs	46.3	46.3	57.3	77.2	132.3
Panel	Dimension (W×H×D)	mm	NA	NA	NA	NA	NA
		in	NA	NA	NA	NA	NA
	Packing (W×H×D)	mm	NA	NA	NA	NA	NA
		in	NA	NA	NA	NA	NA
	Net Weight	kg	NA	NA	NA	NA	NA
		lbs	NA	NA	NA	NA	NA
	Shipping Weight	kg	NA	NA	NA	NA	NA
		lbs	NA	NA	NA	NA	NA
Outdoor Unit	Dimension(W×H×D)	mm	810×580×280	810×580×280	860×670×310	950×840×340	950×1050×340
		in	31-7/8×22-7/8×11	31-7/8×22-7/8×11	33-7/8×26-3/8×12-1/4	37-3/8×33-1/8×13-3/8	37-3/8×41-3/8×13-3/8
	Packing(W×H×D)	mm	940×640×420	940×640×420	990×730×450	1110×920×460	1110×1200×460
		in	37×25-1/4×16-1/2	37×25-1/4×16-1/2	39×28-3/4×17-3/4	43-3/4×36-1/4×18-1/8	43-3/4×47-1/4×18-1/8
	Net Weight	kg	34	36	48	70.5	87
		lbs	75	79.4	105.8	155.1	192
	Shipping Weight	kg	38	40	52	75.5	99
		lbs	83.8	88.2	114.6	166.4	218
Qty'per 20' /40' /40'HQ (Indoor Unit)		Set	160/352/396	160/352/396	128/264/297	84/182/182	35/75/90
Qty'per 20' /40' /40'HQ (Outdoor Unit)		Set	102/204/272	102/204/272	90/186/186	52/106/106	26/53/106

NOTE:

1. Test conditions:

Cooling: Indoor: DB80°F(26.7°C)/ WB67°F(19.4°C) Outdoor: DB95°F(35°C)/ WB75°F(23.9°C)

Heating: Indoor: DB70°F(21.1°C)/ WB60°F(15.6°C) Outdoor: DB47°F(8.3°C)/ WB43°F(6.1°C)

Indoor unit was set with rated ESP and without filter.

2. The Sound Pressure Level is based on the following conditions:

Outdoor unit:

Measure the noise value of 3 points, which are 1 meter in front of the three sides of the unit surface (front/left/right) and 1/2(unit height + 1) meter high from the floor level, and calculate the weighted average of the noise.

Indoor unit:

Measure the noise value of the point 4.6ft(1.4m) below the unit and 3.3ft(1.0m) above the ground.

3. The above data was measured in an anechoic chamber. Please take into consideration the reflected sound of your specific application environment.

4. All specifications are subject to change by the manufacturer without prior notice.

2. SPECIFICATIONS

2.2 Cassette

Model		ADT-09UX3SSBL	ADT-12UX3SSBL	ADT-18UX3SFCL	ADT-24UX3SALM	AUD-36UX3STHH1	
Indoor Model		ADT-09UX3SBL	ADT-12UX3SBL	ADT-18UX3SCL	ADT-24UX3SLM	AUD-36UX3SHH1	
Outdoor Model		AUW-09U3SS	AUW-12U3SS	AUW-18U3SF	AUW-24U3SA	AUW-36U3ST1	
E-STAR_V6.1		Yes	Yes	Yes	Yes	No	
NEEP		Yes	Yes	Yes	Yes	Yes	
Canada Greener Home Program		Yes	Yes	Yes	Yes	Yes	
Power Supply	V/ph/Hz	208/230/1/60	208/230/1/60	208/230/1/60	208/230/1/60	208/230/1/60	
Energy Star		Yes	Yes	Yes	Yes	No	
Cooling	Rated Capacity	Btu/h	9000	12000	18000	24000	36000
	Capacity(MIN-MAX)	Btu/h	4850-11600	5800-13100	4200-21000	8600-25200	12600-36800
	Input	W	700	960	1440	1920	3380
	Current	A	3.2	4.4	6.6	8.8	15.5
	EER2	Btu/h/W	12.85	12.50	12.50	12.50	10.65
	SEER2	Btu/h/W	20.50	20.50	20.50	18.50	18.00
Heating	Rated Capacity	Btu/h	10000	12000	18800	26000	36000
	Capacity(MIN-MAX)	Btu/h	4340-12280	4400-14400	5600-24000	7600-28400	15000-42600
	Input	W	800	926	1410	2113	3190
	Current	A	3.3	4.2	6.5	9.7	14.6
	COP2	W/W	3.66	3.80	3.91	3.61	3.31
	HSPF2	Btu/h/W	10.00	9.50	10.00	10.00	9.80
	Maximum Heating Capacity @5F	Btu/h	8300	8500	13200	19000	26800
	COP @ 5F (Under Maximum	W/W	2.26	2.30	2.36	2.20	2.28
Working Temperature Range	Cooling	°F	5-118	5-118	5-118	5-118	5-118
		°C	-15-48	-15-48	-15-48	-15-48	-15-48
	Heating	°F	-4-75	-4-75	-4-75	-13-75	-4-75
		°C	-20-24	-20-24	-20-24	-25-24	-20-24
Indoor Noise Level (Sound Pressure Hi/Med/Lo)		dB(A)	38/34/31	42/37/33	38/36/34	44/40/38	49/43/39
Outdoor Noise Level (Sound Pressure)		dB(A)	52	52	55	55	61
ESP	Rated	Pa	NA	NA	NA	NA	NA
		in-H ₂ O	NA	NA	NA	NA	NA
	Range	Pa	NA	NA	NA	NA	NA
		in-H ₂ O	NA	NA	NA	NA	NA
Design Pressure	H/L	MPa	3.8/1.6	3.8/1.6	3.8/1.6	3.8/1.6	3.8/1.6
	H/L	PSIG	550/240	550/240	550/240	550/240	550/240
Drainage Water Pipe Diameter		mm/in	dΦ32/(1-1/4)	dΦ32/(1-1/4)	dΦ32/(1-1/4)	dΦ32/(1-1/4)	dΦ32/(1-1/4)
ELECTRICAL DATA							
MIN. AMPACITY		A	7.3	12	15	23	25
MAX. TD FUSE/ BREAKER		A	15	20	20	35	45
Power and Communication Cable		No.x AWG	3x12/4x16	3x14/4x16	3x12/4x16	3x12/4x16	3x10/4x16
Remote Control Adjustable Temperature Range		°C	16 - 30	16-30	16-30	16 - 30	16 - 30
		°F	61-86	61-86	61-86	61-86	61-86
AIR SUPPLY SYSTEM							
Indoor Fan Motor	Model		SIC-62FW-D857-15	SIC-62FW-D857-15	EHDS50AQH	EHDS50AQH	SIC-72FW-D8124-28
	Qty		1	1	1	1	1
	Output	W	57	57	80	80	124

2. SPECIFICATIONS

Model			ADT-09UX3SSBL	ADT-12UX3SSBL	ADT-18UX3SFCL	ADT-24UX3SALM	AUD-36UX3STHH1
Indoor Model			ADT-09UX3SBL	ADT-12UX3SBL	ADT-18UX3SCL	ADT-24UX3SLM	AUD-36UX3SHH1
Outdoor Model			AUW-09U3SS	AUW-12U3SS	AUW-18U3SF	AUW-24U3SA	AUW-36U3ST1
	Capacitor	μF	NA	NA	NA	NA	NA
	Speed(Hi/Med/Lo)	r/min	600/500/400	690/600/500	400/320/260	600/480/390	630/600/570
Indoor Air Flow Rated(Hi/Med/Lo)		m ³ /h	520/460/390	550/500/400	1000/850/670	1100/900/680	1600/1350/1150
		CFM	309/274/232	324/294/235	588/500/394	647/530/400	941//794/676
Outdoor Fan Motor	Model		SIC-52FV-F130-3	SIC-52FV-F130-3	ZWK511A805001	SIC-71FW-D8121-1	SIC-81FW-F1138-1
	Qty		1	1	1	1	1
	Output	W	30	30	60	121	138
	Capacitor	μF	NA	NA	NA	NA	NA
	Speed (Hi)	r/min	850	880	880	830	850
Outdoor Air Flow		m ³ /h	2300	2300	3150	3800	5800
		CFM	1354	1354	1854	2237	3414
REFRIGERATION SYSTEM							
Indoor Coil	Number of Rows		2	3	2	3	3
	Tube Pitch(a)	mm	21	21	21	21	21
		in	13/16	13/16	13/16	13/16	13/16
	Row Pitch(b)	mm	9.4	9.4	13.6	13.6	13.6
		in	3/8	3/8	17/32	17/32	17/32
	Fin Spacing	mm	1.3	1.3	1.5	1.5	1.5
		Fins Per in	20	20	17	17	17
	Fin Type		Hydrophilic aluminium	Hydrophilic aluminium	Hydrophilic aluminium	Hydrophilic aluminium	Hydrophilic aluminium
Tube Outside Diameter and	mm	Φ5, rifled tube	Φ5, innergroove tube	Φ7, innergroove tube	Φ7, innergroove tube	Φ7, innergroove tube	
Number of Circuits		6	6	3	6	6	
Outdoor coil	Number of Rows		2	2	2	2	2
	Tube Pitch(a)	mm	21	21	21	21	21
		in	53/64	53/64	53/64	53/64	53/64
	Row Pitch(b)	mm	18.19	21.65	21.65	21.65	21.65
		in	3/4	7/8	7/8	7/8	7/8
	Fin Spacing	mm	1.5	1.5	1.4	1.3	1.6
		Fins Per in	17	17	18	20	16
	Fin Type		Hydrophilic aluminium	Hydrophilic aluminium	Hydrophilic aluminium	Hydrophilic aluminium	Hydrophilic aluminium
Tube Outside Diameter and	mm	Φ7, innergroove tube	Φ7, innergroove tube	Φ7.94, innergroove tube	Φ7.94, innergroove tube	Φ7.94, innergroove tube	
Number of Circuits		4	3	3	5	6	
Throttle Type		EEV	EEV	EEV	EEV	EEV	
Compressor	Model		ASN108D43UFZ A	ASN108D43UFZ A	ATM150D23UFZ	EATF250D22UM T	ATF310D43UMT
	Type		ROTARY	ROTARY	ROTARY	ROTARY	ROTARY
	Capacity	Btu/h	11090	11090	15422	26085	32380
	Input	W	810	810	1165	2080	2600
	Rated Current(RLA)	A	4.9	8.1	10	16.1	20
	Refrigerant Oil	ml	ESTER OIL VG74 / 370	ESTER OIL VG74/370	ESTEL OIL VG74/500	VG74 /670	PQE VG74/1000
oz.		ESTER OIL VG74 / 12.5	ESTER OIL VG74/12.5	ESTEL OIL VG74/16.9	VG74 /22.7	PQE VG74/33.8	
Refrigerant Type/Quantity	Type		R-410A	R-410A	R-410A	R-410A	R-410A
	Refrigerant Charge	kg	0.95	1.3	1.6	2.6	3.15
		oz.	33.5	45.9	56.44	91.7	111.2
Factory Precharge	Ft.	25	25	25	25	25	

2. SPECIFICATIONS

Model			ADT-09UX3SSBL	ADT-12UX3SSBL	ADT-18UX3SFCL	ADT-24UX3SALM	AUD-36UX3STHH1
Indoor Model			ADT-09UX3SBL	ADT-12UX3SBL	ADT-18UX3SCL	ADT-24UX3SLM	AUD-36UX3SHH1
Outdoor Model			AUW-09U3SS	AUW-12U3SS	AUW-18U3SF	AUW-24U3SA	AUW-36U3ST1
	Additional Charge for Each Ft.	oz.	0.161	0.161	0.161	0.376	0.376
Refrigerant Piping	Liquid Line OD	mm/in	Φ6.35/(1/4)	Φ6.35/(1/4)	Φ6.35(1/4')	Φ9.52(3/8')	Φ9.52(3/8')
	Vapor Line OD	mm/in	Φ9.52/(3/8)	Φ9.52/(3/8)	Φ12.7(1/2')	Φ15.88(5/8')	Φ19.05(3/4')
	Max. Pipe Length	m	25	25	30	50	50
		Ft.	82	82	98	164	164
	Max. Difference in Level	m	15	15	15	30	30
Ft.		49	49	49	98	98	
DIMENSIONS & WEIGHT							
Indoor Unit	Dimension (W×H×D)	mm	570×215×570	570×215×570	840×248×840	840×248×840	840×298×840
		in	22-1/2×8-1/2×22-1/2	22-1/2×8-1/2×22-1/2	33-1/8×9-3/4×33-1/8	33-1/8×9-3/4×33-1/8	33-1/8×11-3/4×33-1/8
	Packing(L×W×H)	mm	730×668×292	730×668×292	996×956×370	996×956×370	996×956×420
		in	28-3/4 ×26-1/4 ×11-1/2	28-3/4 ×26-1/4 ×11-1/2	39-1/4 ×37-5/8 ×14-5/8	39-1/4 ×37-5/8 ×14-5/8	39-1/4 ×37-5/8 ×16-1/2
	Net Weight	kg	14.5	15.5	25	27	32
		lbs	32	34	56	59.5	70.5
	Shipping Weight	kg	17.5	18.5	34	36	41
		lbs	38.5	40.5	76	79.5	90.5
Panel	Dimension (W×H×D)	mm	620×40×620	620×40×620	950×45×950	950×45×950	950×45×950
		in	24-3/8×1-5/8×24-3/8	24-3/8×1-5/8×24-3/8	37-3/8×1-3/4×37-3/8	37-3/8×1-3/4×37-3/8	37-3/8×1-3/4×37-3/8
	Packing (L×W×H)	mm	690×680×115	690×680×115	1025×1015×120	1025×1015×120	1025×1015×120
		in	27-1/8 ×26-3/4 ×4-1/2	27-1/8 ×26-3/4 ×4-1/2	40-3/8 ×40 ×4-3/4	40-3/8 ×40 ×4-3/4	40-3/8 ×40 ×4-3/4
	Net Weight	kg	2.6	2.6	6.5	6.5	6.5
		lbs	5.7	5.7	14.3	14.3	14.3
	Shipping Weight	kg	4.5	4.5	9.5	9.5	9.5
		lbs	9.9	9.9	20.9	20.9	20.9
Outdoor Unit	Dimension(W×H×D)	mm	810×580×280	810×580×280	860×670×310	950×840×340	950×1050×340
		in	31-7/8×22-7/8×11	31-7/8×22-7/8×11	33-7/8×26-3/8×12-1/4	37-3/8×33-1/8×13-3/8	37-3/8×41-3/8×13-3/8
	Packing(W×H×D)	mm	940×640×420	940×640×420	990×730×450	1110×920×460	1110×1200×460
		in	37×25-1/4×16-1/2	37×25-1/4×16-1/2	39×28-3/4×17-3/4	43-3/4×36-1/4×18-1/8	43-3/4×47-1/4×18-1/8
	Net Weight	kg	34	36	48	70.5	87
		lbs	75	79.4	105.8	155.1	192
	Shipping Weight	kg	38	40	52	75.5	99
		lbs	83.8	88.2	114.6	166.4	218
Qty/per 20' /40' /40HQ (Indoor Unit)		Set	140/298/330	140/298/330	60/120/144	60/120/144	60/120/144
Qty/per 20' /40' /40HQ (Outdoor Unit)		Set	102/204/272	102/204/272	90/186/186	52/106/106	26/53/106

NOTE:

1. Test conditions:

Cooling: Indoor: DB80°F(26.7°C)/ WB67°F(19.4°C) Outdoor: DB95°F(35°C)/ WB75°F(23.9°C)

Heating: Indoor: DB70°F(21.1°C)/ WB60°F(15.6°C) Outdoor: DB47°F(8.3°C)/ WB43°F(6.1°C)

2. The Sound Pressure Level is based on the following conditions:

Outdoor unit:

Measure the noise value of 3 points, which are 1 meter in front of the three sides of the unit surface (front/left/right) and 1/2(unit height +1) meter high from the floor level, and calculate the weighted average of the noise.

Indoor unit:

Measure the noise value of the point 4.6ft(1.4m) below the unit and 3.3ft(1.0m) above the ground.

3. The above data was measured in an anechoic chamber. Please take into consideration the reflected sound of your specific application environment.

4. All specifications are subject to change by the manufacturer without prior notice.

3. OUTLINES AND DIMENSIONS

3. Outlines and dimensions

3.1 Indoor units

Duct

9K/12K/18K

Unit : in.(mm)

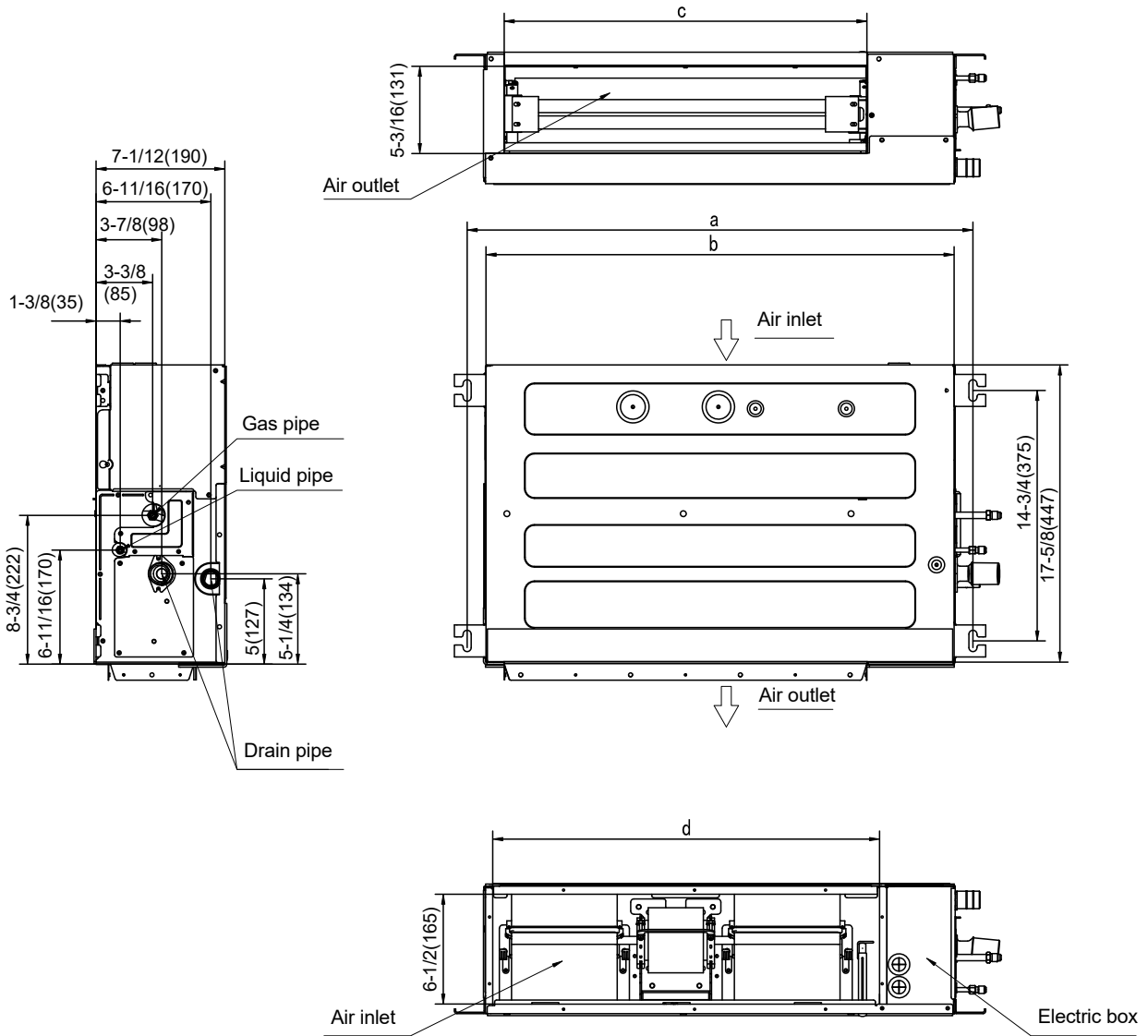

Model (Btu/h)	a	b	c	d
9K/12K	37-13/16 (961)	35-13/16 (910)	29-1/2 (749)	30 (786)
18K	48-7/16 (1231)	46-7/16 (1180)	40-1/8 (1019)	41-5/8 (1056)

3. OUTLINES AND DIMENSIONS

Cassette

9K/12K

Unit: in.(mm)

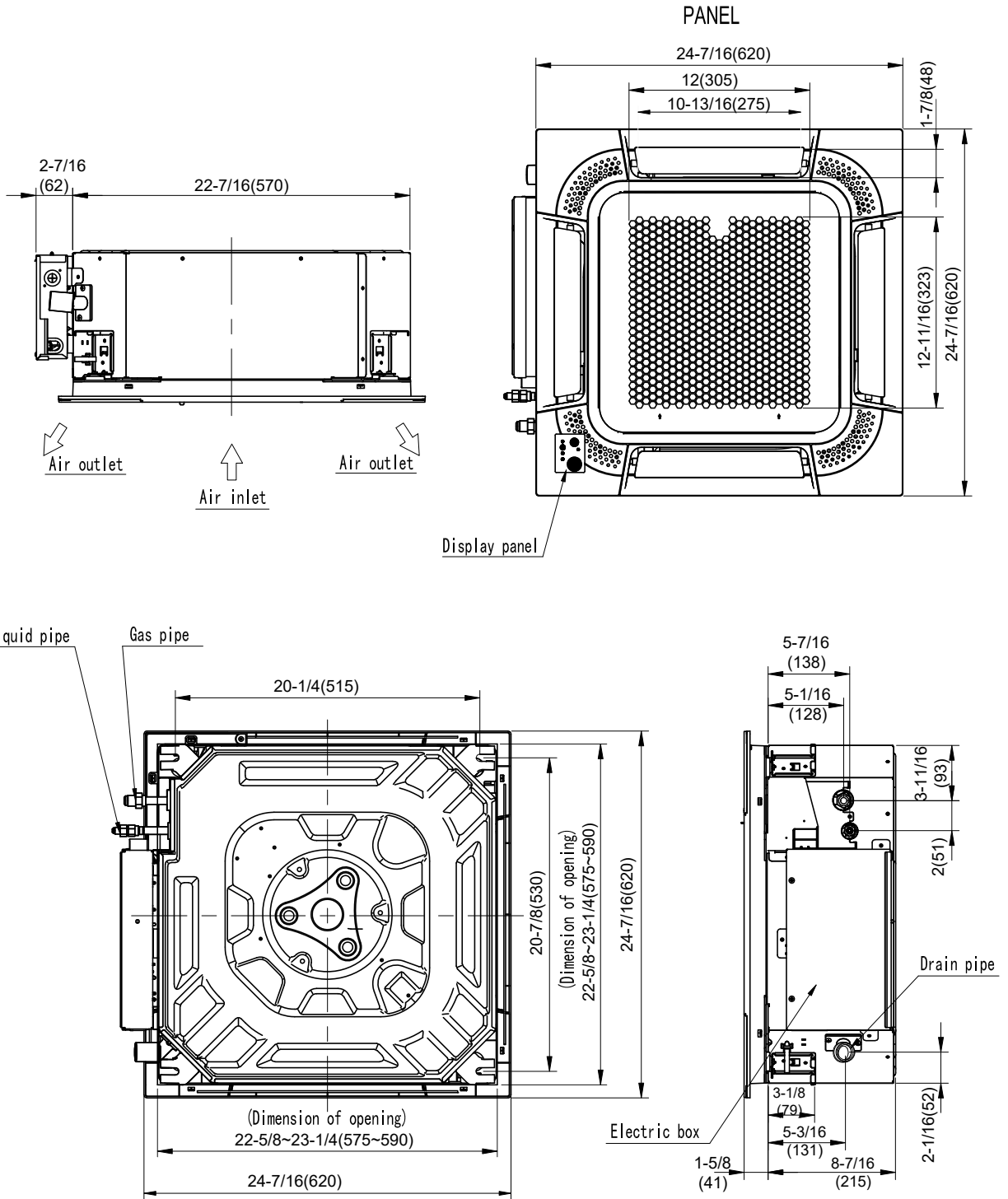

3. OUTLINES AND DIMENSIONS

18K/24K/36K

Unit: in.(mm)

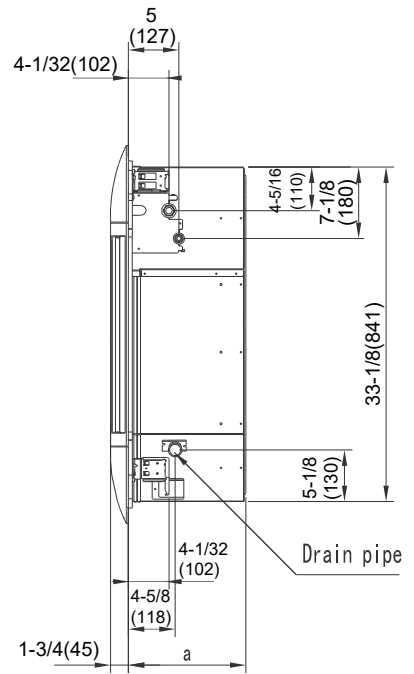
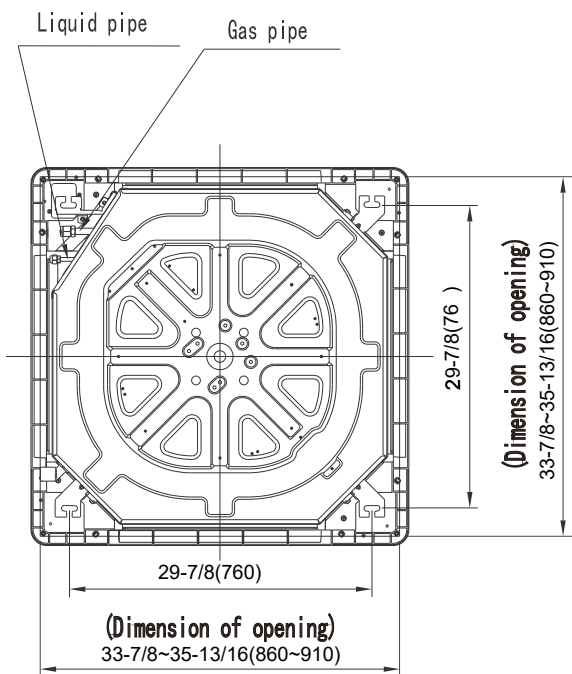
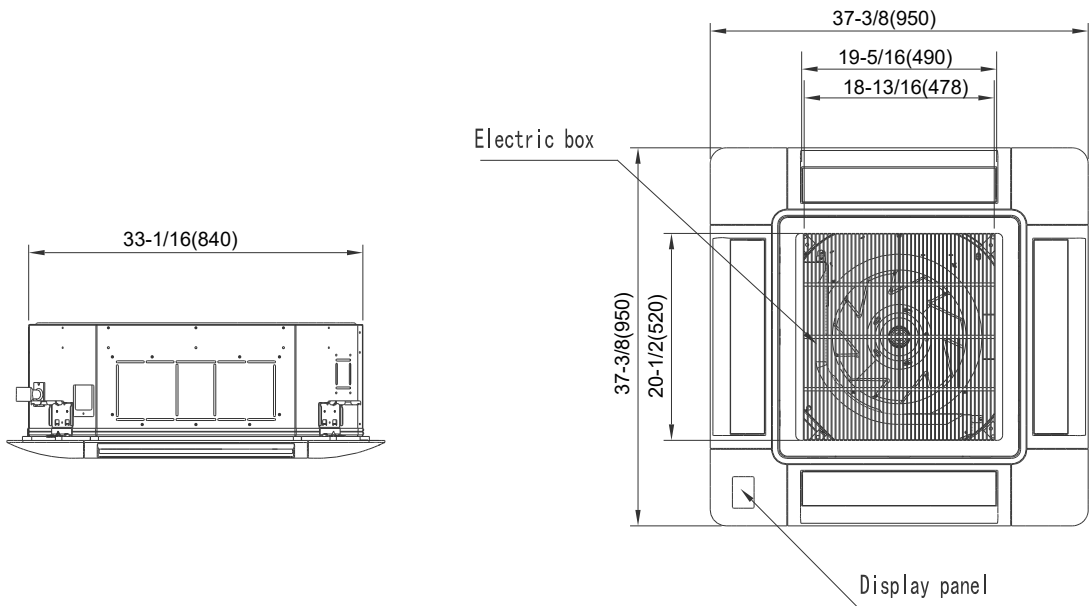

Model	a
18K/24K	9-3/4(248)
36K	11-3/4(298)

3. OUTLINES AND DIMENSIONS

3.2 Outdoor units

9K/12K

Unit: in.(mm)

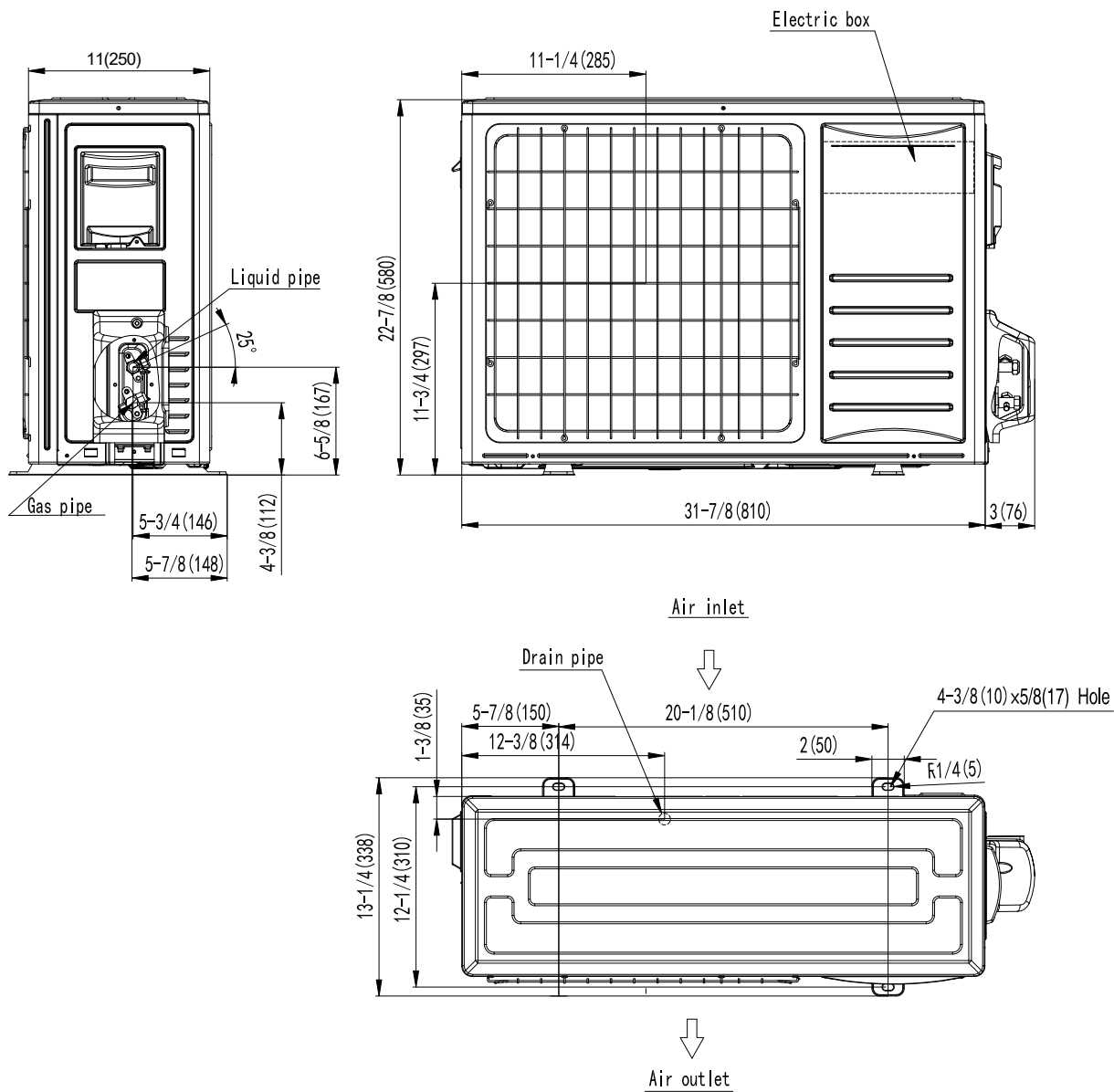

3. OUTLINES AND DIMENSIONS

18K

Unit: in.(mm)

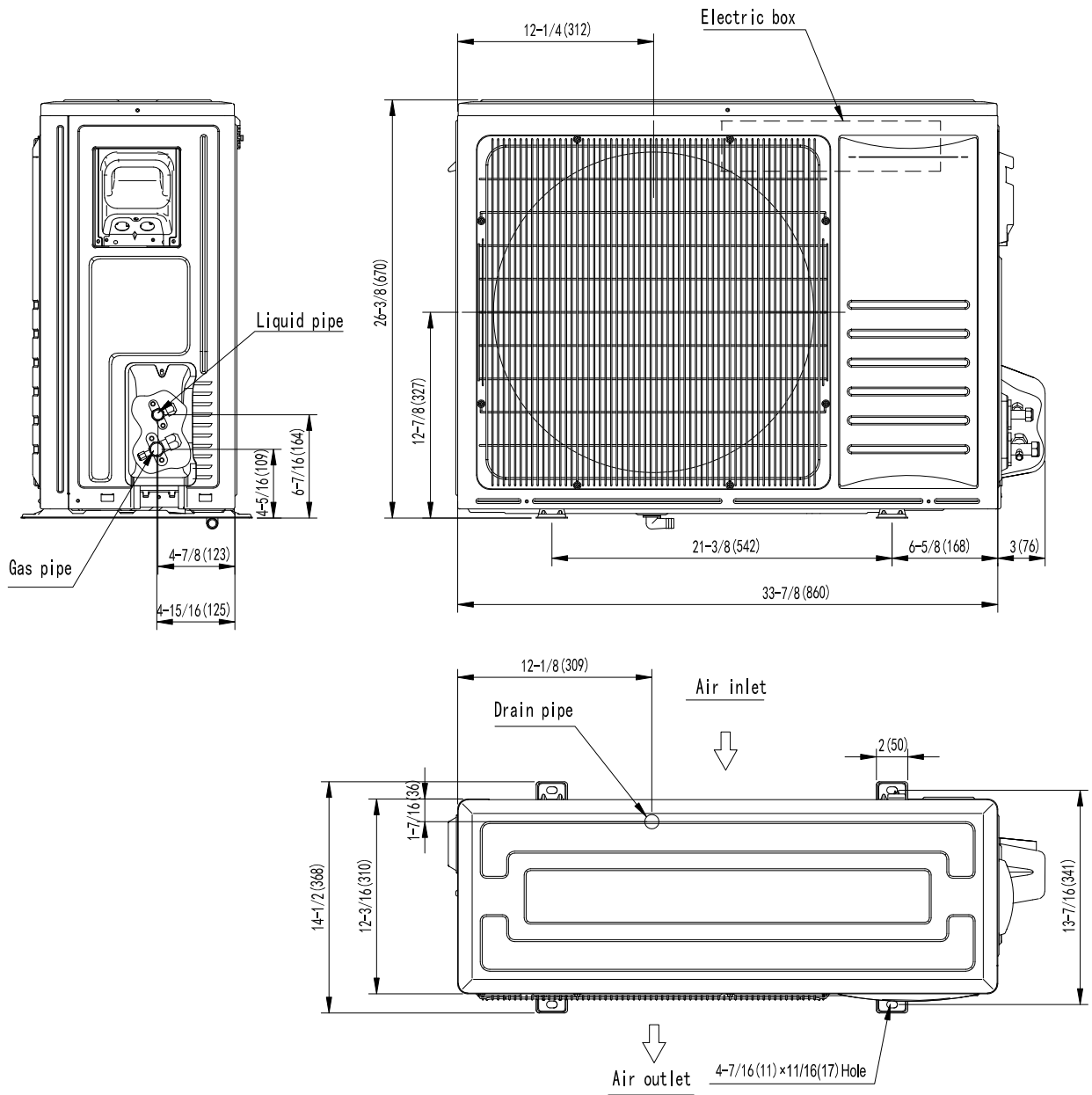

3. OUTLINES AND DIMENSIONS

24K

Unit: in.(mm)

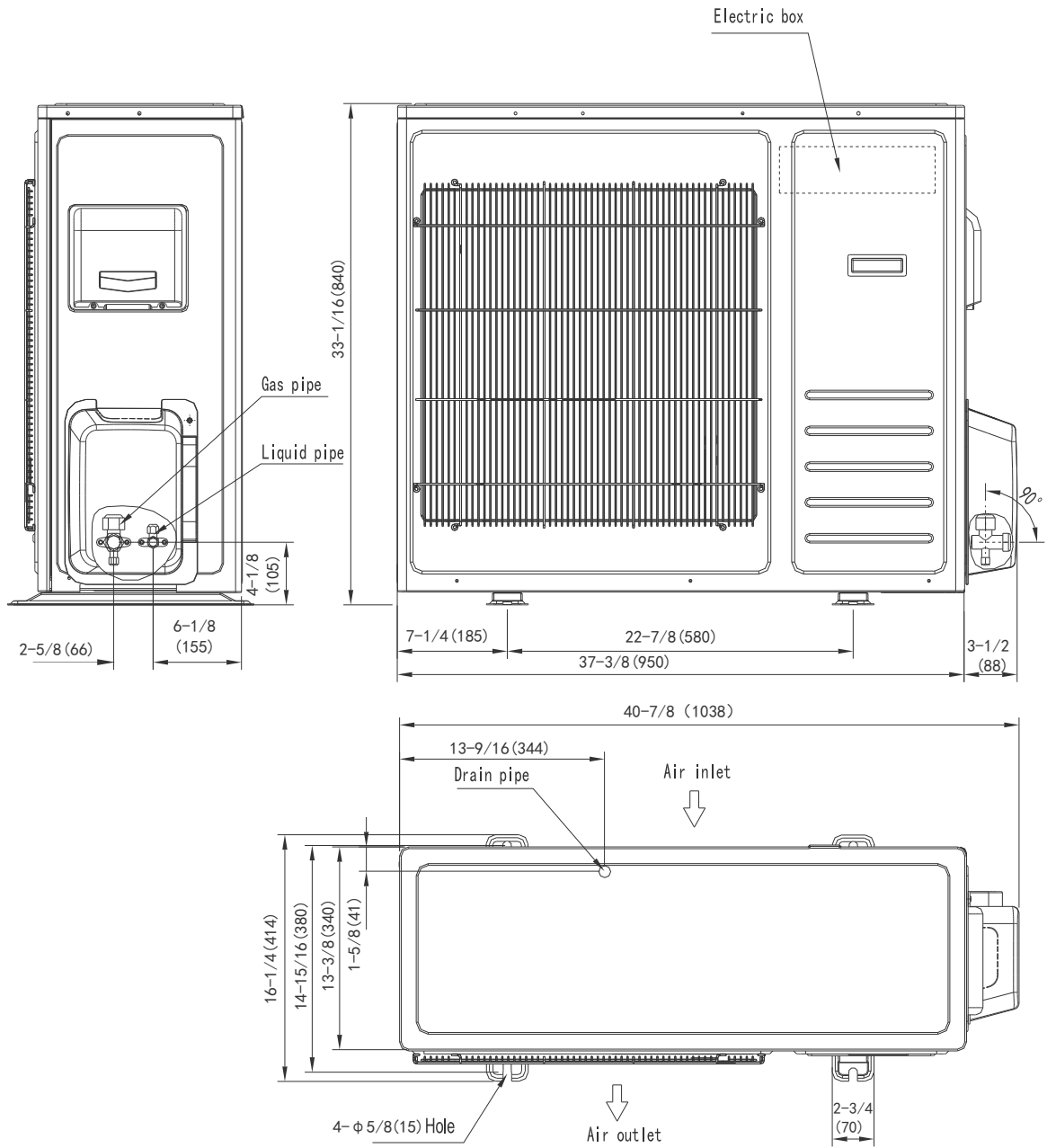

3. OUTLINES AND DIMENSIONS

36K

Unit: in.(mm)

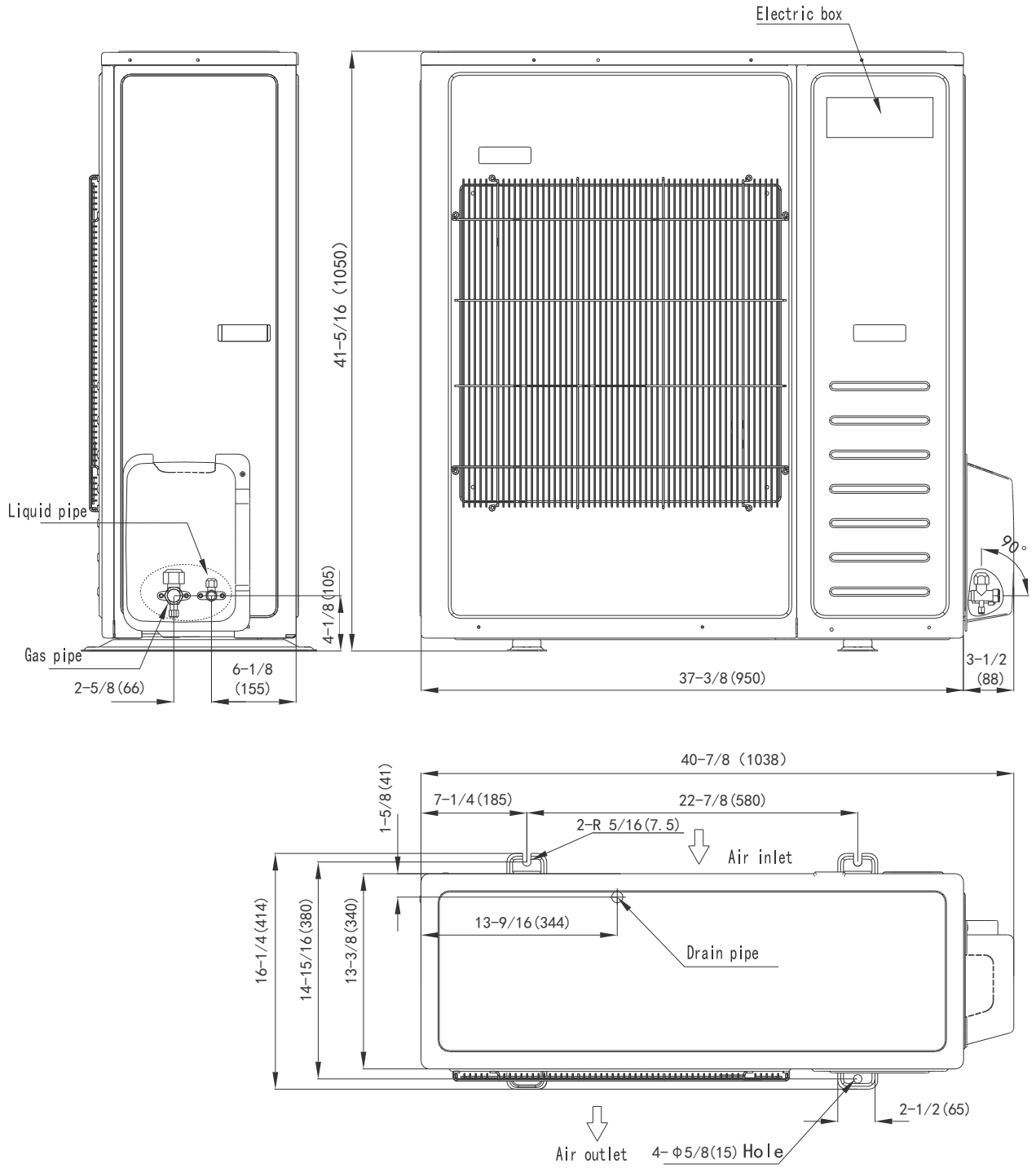

4. ELECTRICAL DATA

4. Electrical data

Outdoor unit	Power supply			Applicable voltage		ELB	
	Voltage(V)	PH	Frequency (Hz)	Umin(V)	Umax(V)	Nominal Current(A)	Nominal Sensitive Current(mA)
9K/12K	208/230V ~	1	60	198	253	20	30
18K	208/230V ~	1	60	198	253	32	30
24K/36K	208/230V ~	1	60	176	253	32	30

NOTE:

1. The above compressor data is based on 100% capacity combination of indoor units at the rated operating frequency.
2. This data is based on the same conditions as the nominal heating and cooling capacities.
3. The compressor is started by an inverter, resulting in extremely low starting current.

5. CAPACITIES AND SELECTION DATA

5. Capacities and selection data

5.1 Capacity characteristic charts

The following charts show the characteristics of outdoor unit capacity, which corresponds with the operating ambient temperature of outdoor unit.

Conditions:

- ① Pipe length / height difference : 25 ft. (7.6m) / 0 ft. (0m)
- ② Compressor at rated inverter frequency
- ③ Indoor fan speed at high fan speed
- ④ Capacity loss due to white frost and defrost operation is not included.

5. CAPACITIES AND SELECTION DATA

Ducted

Cooling Capacity Table																			
Model	Outdoor Air Temp. (°F DB)	Indoor Air Temp. °F DB / °F WB																	
		68 / 57			73 / 61			77 / 64			80 / 67			86 / 72			90 / 75		
		TC	SHC	PI	TC	SHC	PI	TC	SHC	PI	TC	SHC	PI	TC	SHC	PI	TC	SHC	PI
1.0HP (9K)	5	8.91	7.14	0.30	9.47	7.54	0.41	10.02	7.76	0.44	10.42	7.46	0.45	11.13	7.52	0.45	11.68	7.66	0.45
	10	8.90	7.19	0.31	9.45	7.60	0.42	10.01	7.82	0.45	10.41	7.51	0.46	11.12	7.58	0.46	11.67	7.72	0.46
	15	8.89	7.25	0.32	9.44	7.65	0.43	9.99	7.88	0.47	10.39	7.56	0.47	11.10	7.63	0.47	11.65	7.77	0.47
	20	8.88	7.29	0.32	9.43	7.71	0.44	9.98	7.93	0.48	10.38	7.62	0.48	11.08	7.68	0.48	11.63	7.83	0.48
	25	8.87	7.35	0.33	9.41	7.76	0.45	9.96	7.99	0.49	10.36	7.67	0.50	11.07	7.74	0.50	11.62	7.88	0.50
	30	8.85	7.40	0.34	9.40	7.82	0.46	9.95	8.04	0.50	10.35	7.73	0.51	11.05	7.79	0.51	11.60	7.94	0.51
	35	8.84	7.45	0.35	9.39	7.87	0.47	9.94	8.10	0.51	10.33	7.78	0.52	11.03	7.85	0.52	11.58	8.00	0.52
	40	8.82	7.50	0.36	9.38	7.92	0.48	9.92	8.16	0.53	10.32	7.83	0.53	11.02	7.90	0.53	11.57	8.05	0.53
	45	8.81	7.55	0.37	9.36	7.98	0.50	9.91	8.21	0.54	10.30	7.89	0.54	11.00	7.95	0.55	11.55	8.10	0.54
	50	8.80	7.60	0.38	9.35	8.03	0.51	9.89	8.27	0.55	10.29	7.94	0.56	10.99	8.01	0.56	11.53	8.16	0.56
	55	8.79	7.65	0.38	9.33	8.09	0.52	9.88	8.32	0.56	10.27	7.99	0.57	10.97	8.06	0.57	11.52	8.21	0.57
	60	8.78	7.70	0.39	9.32	8.14	0.53	9.86	8.38	0.57	10.26	8.04	0.58	10.95	8.11	0.59	11.50	8.27	0.58
	65	8.76	7.75	0.40	9.30	8.19	0.54	9.85	8.43	0.59	10.24	8.10	0.60	10.94	8.16	0.60	11.48	8.32	0.60
	70	8.75	7.80	0.41	9.29	8.24	0.55	9.84	8.49	0.60	10.23	8.15	0.61	10.92	8.22	0.61	11.46	8.37	0.61
	75	8.54	7.67	0.44	9.08	8.12	0.57	9.62	8.37	0.62	10.01	8.04	0.63	10.71	8.12	0.63	11.25	8.28	0.63
	80	8.33	7.54	0.46	8.87	7.99	0.59	9.41	8.24	0.63	9.80	7.93	0.64	10.49	8.02	0.65	11.03	8.18	0.66
	85	8.12	7.41	0.53	8.66	7.86	0.64	9.20	8.12	0.68	9.59	7.81	0.69	10.28	7.91	0.70	10.82	8.08	0.71
	90	7.91	7.26	0.59	8.45	7.72	0.69	8.99	7.98	0.72	9.38	7.69	0.74	10.06	7.80	0.75	10.60	7.97	0.76
95	7.68	7.19	0.65	8.22	7.65	0.74	8.76	7.92	0.76	9.00	7.52	0.75	9.83	7.76	0.79	10.36	7.94	0.80	
100	7.50	7.00	0.68	8.03	7.46	0.75	8.57	7.73	0.77	8.88	7.41	0.76	9.64	7.59	0.79	10.17	7.77	0.80	
105	7.31	6.80	0.71	7.85	7.26	0.77	8.38	7.55	0.77	8.77	7.29	0.78	9.45	7.42	0.79	9.99	7.61	0.80	
110	7.12	6.57	0.69	7.66	7.03	0.72	8.19	7.31	0.72	8.58	7.07	0.72	9.26	7.21	0.72	9.80	7.40	0.74	
115	6.93	6.38	0.62	7.47	6.83	0.63	8.01	7.12	0.62	8.39	6.89	0.60	9.08	7.04	0.61	9.61	7.23	0.62	
118	6.55	6.08	0.55	7.07	6.52	0.54	7.58	6.80	0.52	7.95	6.59	0.51	8.61	6.74	0.51	9.12	6.93	0.52	
122	6.42	5.97	0.53	6.93	6.41	0.51	7.44	6.69	0.49	7.80	6.48	0.47	8.45	6.63	0.47	8.96	6.82	0.48	

Heating Capacity Tables															
Model No. / Nominal Capacity (Btu/h)	Outdoor Air Temp. (°F DB)		Indoor Air Temp. °F DB / °F WB												
	°F DB	°F WB	61		64		68		70		72		75		
			TC	PI	TC	PI	TC	PI	TC	PI	TC	PI	TC	PI	
1.0HP (9K)	-4	-4.4	4.36	0.62	4.06	0.64	4.11	0.65	4.01	0.65	3.93	0.65	3.76	0.68	
	0	-0.4	4.95	0.63	4.66	0.65	4.66	0.66	4.55	0.67	4.47	0.67	4.28	0.70	
	5	4.5	5.79	0.64	5.52	0.66	5.44	0.67	5.33	0.68	5.23	0.69	5.02	0.71	
	10	9	6.36	0.64	6.10	0.67	5.96	0.69	5.84	0.69	5.74	0.70	5.52	0.72	
	17	15	6.98	0.66	6.73	0.68	6.54	0.70	6.41	0.71	6.31	0.72	6.07	0.74	
	20	19	7.35	0.67	7.12	0.69	6.89	0.71	6.76	0.72	6.65	0.73	6.40	0.75	
	25	23	7.98	0.68	7.74	0.70	7.47	0.73	7.33	0.74	7.22	0.75	6.95	0.77	
	30	28	8.61	0.70	8.34	0.72	8.05	0.74	7.91	0.76	7.79	0.77	7.50	0.79	
	35	32	9.23	0.72	8.94	0.74	8.64	0.76	8.48	0.78	8.36	0.79	8.05	0.81	
	40	36	9.70	0.74	9.43	0.76	9.13	0.78	8.97	0.80	8.85	0.81	8.53	0.84	
	45	41	10.30	0.76	10.05	0.79	9.75	0.81	9.59	0.83	9.46	0.84	9.11	0.87	
	47	43	10.53	0.77	10.30	0.80	10.00	0.83	9.84	0.84	9.70	0.85	9.35	0.88	
	50	46	10.56	0.77	10.35	0.79	10.09	0.81	9.95	0.83	9.83	0.84	9.50	0.86	
	55	51	10.61	0.76	10.44	0.78	10.24	0.80	10.12	0.81	10.03	0.81	9.73	0.83	
60	56	10.66	0.75	10.52	0.77	10.39	0.78	10.31	0.79	10.23	0.79	9.97	0.80		
63	59	10.69	0.75	10.58	0.76	10.48	0.77	10.42	0.78	10.36	0.78	10.12	0.79		
68	64	10.72	0.74	10.63	0.75	10.58	0.76	10.52	0.76	10.48	0.77	10.26	0.77		

Remarks:
 TC: Total Capacity (Gross) (kBtu/h)
 SHC: Sensible Heat Capacity (Gross)
 PI: Power Input (including the compressor, evap. fan motor & cond. fan motor) (kW)
 DB: Dry Bulb Temperature
 WB: Wet Bulb Temperature

5. CAPACITIES AND SELECTION DATA

Cooling Capacity Table																			
Model	Outdoor Air Temp. (°F DB)	Indoor Air Temp. °F DB / °F WB																	
		68 / 57			73 / 61			77 / 64			80 / 67			86 / 72			90 / 75		
		TC	SHC	PI	TC	SHC	PI	TC	SHC	PI	TC	SHC	PI	TC	SHC	PI	TC	SHC	PI
1.5HP (12K)	5	11.89	9.52	0.44	12.63	10.06	0.59	13.37	10.35	0.64	13.90	9.94	0.65	14.84	10.03	0.65	15.58	10.22	0.65
	10	11.87	9.59	0.45	12.61	10.13	0.61	13.35	10.43	0.65	13.88	10.02	0.67	14.82	10.10	0.67	15.56	10.29	0.67
	15	11.85	9.66	0.46	12.59	10.21	0.62	13.33	10.50	0.68	13.86	10.09	0.68	14.80	10.17	0.69	15.54	10.37	0.68
	20	11.84	9.73	0.47	12.57	10.28	0.64	13.31	10.58	0.69	13.84	10.16	0.70	14.78	10.25	0.70	15.51	10.44	0.70
	25	11.82	9.80	0.49	12.55	10.35	0.65	13.29	10.65	0.71	13.82	10.23	0.72	14.76	10.32	0.72	15.49	10.51	0.72
	30	11.80	9.87	0.50	12.54	10.42	0.67	13.27	10.73	0.73	13.80	10.30	0.74	14.74	10.39	0.74	15.47	10.59	0.74
	35	11.79	9.94	0.51	12.52	10.49	0.69	13.25	10.80	0.75	13.78	10.38	0.76	14.71	10.46	0.76	15.45	10.66	0.76
	40	11.77	10.00	0.52	12.50	10.57	0.70	13.23	10.88	0.76	13.76	10.45	0.77	14.69	10.53	0.77	15.42	10.73	0.77
	45	11.75	10.07	0.53	12.48	10.64	0.72	13.21	10.95	0.78	13.74	10.52	0.79	14.67	10.61	0.80	15.40	10.81	0.79
	50	11.74	10.14	0.55	12.46	10.71	0.74	13.19	11.02	0.80	13.72	10.59	0.81	14.65	10.68	0.81	15.38	10.88	0.81
	55	11.72	10.21	0.56	12.45	10.78	0.75	13.17	11.10	0.82	13.70	10.66	0.83	14.63	10.75	0.83	15.36	10.95	0.83
	60	11.70	10.27	0.57	12.43	10.85	0.77	13.15	11.17	0.83	13.68	10.73	0.85	14.61	10.82	0.85	15.33	11.02	0.85
	65	11.68	10.34	0.58	12.41	10.92	0.79	13.14	11.24	0.85	13.66	10.80	0.87	14.59	10.89	0.87	15.31	11.10	0.87
	70	11.67	10.41	0.59	12.39	10.99	0.80	13.12	11.32	0.87	13.64	10.87	0.88	14.57	10.96	0.88	15.29	11.17	0.88
	75	11.39	10.23	0.63	12.11	10.83	0.83	12.83	11.16	0.89	13.35	10.72	0.91	14.28	10.83	0.92	15.00	11.04	0.92
	80	11.11	10.06	0.67	11.83	10.65	0.86	12.55	10.99	0.92	13.07	10.57	0.93	13.99	10.69	0.95	14.71	10.91	0.96
	85	10.83	9.88	0.76	11.55	10.48	0.93	12.27	10.82	0.99	12.79	10.42	1.00	13.70	10.55	1.02	14.42	10.77	1.04
	90	10.55	9.69	0.85	11.27	10.29	1.00	11.98	10.65	1.05	12.50	10.26	1.07	13.42	10.40	1.09	14.14	10.63	1.11
	95	10.25	9.59	0.94	10.96	10.20	1.07	11.68	10.57	1.11	12.00	10.03	1.09	13.10	10.34	1.15	13.82	10.59	1.17
	100	10.00	9.33	0.99	10.71	9.94	1.09	11.43	10.31	1.12	11.85	9.88	1.11	12.85	10.12	1.15	13.57	10.37	1.17
105	9.75	9.07	1.04	10.46	9.69	1.11	11.18	10.06	1.12	11.69	9.72	1.13	12.60	9.90	1.15	13.32	10.15	1.17	
110	9.50	8.76	1.01	10.21	9.37	1.05	10.93	9.75	1.05	11.44	9.43	1.04	12.35	9.62	1.05	13.07	9.87	1.08	
115	9.25	8.50	0.91	9.96	9.11	0.92	10.68	9.49	0.89	11.19	9.19	0.88	12.10	9.39	0.88	12.82	9.65	0.91	
118	8.74	8.10	0.80	9.42	8.69	0.79	10.11	9.07	0.75	10.60	8.78	0.74	11.48	8.98	0.74	12.16	9.24	0.75	
122	8.56	7.97	0.77	9.24	8.55	0.75	9.92	8.92	0.71	10.40	8.65	0.69	11.27	8.84	0.69	11.94	9.10	0.70	

Heating Capacity Tables														
Model No. / Nominal Capacity (Btu/h)	Outdoor Air Temp. (°F DB)		Indoor Air Temp. °F DB / °F WB											
	°F DB	°F WB	61		64		68		70		72		75	
			TC	PI	TC	PI	TC	PI	TC	PI	TC	PI	TC	PI
1.5HP (12K)	-4	-4.4	5.23	0.82	4.87	0.85	4.93	0.85	4.81	0.86	4.71	0.86	4.51	0.90
	0	-0.4	5.94	0.83	5.60	0.86	5.59	0.87	5.46	0.88	5.36	0.89	5.14	0.92
	5	4.5	6.95	0.84	6.63	0.87	6.53	0.89	6.39	0.90	6.28	0.91	6.03	0.94
	10	9	7.63	0.85	7.32	0.88	7.16	0.91	7.01	0.92	6.89	0.93	6.62	0.95
	17	15	8.37	0.87	8.08	0.90	7.85	0.93	7.69	0.94	7.57	0.95	7.28	0.98
	20	19	8.82	0.88	8.54	0.91	8.27	0.94	8.11	0.95	7.98	0.97	7.68	0.99
	25	23	9.57	0.90	9.29	0.93	8.97	0.96	8.80	0.98	8.66	0.99	8.34	1.02
	30	28	10.33	0.93	10.01	0.95	9.67	0.98	9.49	1.00	9.35	1.02	9.00	1.05
	35	32	11.08	0.95	10.73	0.98	10.37	1.01	10.18	1.03	10.03	1.05	9.67	1.08
	40	36	11.65	0.97	11.32	1.01	10.96	1.04	10.77	1.06	10.62	1.08	10.23	1.11
	45	41	12.35	1.01	12.06	1.04	11.70	1.08	11.51	1.10	11.35	1.11	10.94	1.14
	47	43	12.63	1.02	12.35	1.06	12.00	1.09	11.80	1.11	11.65	1.13	11.22	1.16
	50	46	12.67	1.02	12.42	1.05	12.11	1.08	11.93	1.10	11.79	1.11	11.40	1.14
	55	51	12.73	1.01	12.52	1.03	12.29	1.06	12.15	1.07	12.04	1.08	11.68	1.10
	60	56	12.80	0.99	12.63	1.01	12.47	1.03	12.37	1.04	12.28	1.05	11.97	1.06
	63	59	12.83	0.99	12.69	1.00	12.58	1.02	12.50	1.03	12.43	1.03	12.14	1.04
68	64	12.87	0.98	12.76	0.99	12.70	1.01	12.63	1.01	12.58	1.01	12.31	1.02	

Remarks:
 TC: Total Capacity (Gross) (kBtu/h)
 SHC: Sensible Heat Capacity (Gross)
 PI: Power Input (including the compressor,
 evap. fan motor & cond. fan motor) (kW)
 DB: Dry Bulb Temperature
 WB: Wet Bulb Temperature

5. CAPACITIES AND SELECTION DATA

Cooling Capacity Table																			
Model	Outdoor Air Temp. (°F DB)	Indoor Air Temp. °F DB / °F WB																	
		68 / 57			73 / 61			77 / 64			80 / 67			86 / 72			90 / 75		
		TC	SHC	PI	TC	SHC	PI	TC	SHC	PI	TC	SHC	PI	TC	SHC	PI	TC	SHC	PI
2.0HP (18K)	5	17.83	14.28	0.67	18.94	15.08	0.90	20.05	15.53	0.98	20.84	14.91	0.99	22.26	15.04	0.99	23.36	15.32	0.99
	10	17.81	14.39	0.68	18.91	15.20	0.93	20.02	15.64	1.00	20.81	15.02	1.02	22.23	15.15	1.02	23.33	15.44	1.02
	15	17.78	14.49	0.70	18.89	15.31	0.95	19.99	15.75	1.04	20.78	15.13	1.04	22.19	15.26	1.05	23.30	15.55	1.04
	20	17.75	14.59	0.72	18.86	15.41	0.98	19.96	15.86	1.06	20.75	15.24	1.08	22.16	15.37	1.08	23.27	15.66	1.08
	25	17.73	14.69	0.74	18.83	15.53	1.00	19.93	15.98	1.09	20.72	15.35	1.10	22.13	15.47	1.10	23.24	15.77	1.10
	30	17.70	14.80	0.76	18.80	15.63	1.03	19.90	16.09	1.11	20.69	15.45	1.13	22.10	15.59	1.14	23.20	15.88	1.13
	35	17.68	14.90	0.78	18.77	15.74	1.05	19.88	16.20	1.14	20.66	15.56	1.16	22.07	15.69	1.16	23.17	15.99	1.16
	40	17.65	15.00	0.79	18.75	15.85	1.08	19.85	16.31	1.17	20.63	15.67	1.19	22.04	15.80	1.19	23.13	16.10	1.19
	45	17.63	15.11	0.82	18.72	15.95	1.10	19.82	16.43	1.19	20.60	15.77	1.21	22.01	15.91	1.22	23.10	16.21	1.21
	50	17.60	15.20	0.84	18.69	16.06	1.13	19.79	16.53	1.22	20.57	15.88	1.24	21.98	16.01	1.24	23.06	16.31	1.24
	55	17.57	15.31	0.85	18.67	16.17	1.15	19.76	16.64	1.25	20.54	15.98	1.27	21.94	16.12	1.27	23.03	16.43	1.27
	60	17.55	15.41	0.87	18.64	16.28	1.18	19.73	16.76	1.28	20.51	16.09	1.29	21.91	16.22	1.30	23.00	16.53	1.29
	65	17.52	15.50	0.89	18.61	16.38	1.20	19.70	16.86	1.30	20.48	16.19	1.33	21.88	16.33	1.33	22.97	16.64	1.33
	70	17.50	15.61	0.91	18.59	16.49	1.23	19.67	16.97	1.34	20.45	16.30	1.35	21.85	16.43	1.35	22.93	16.75	1.35
	75	17.08	15.35	0.97	18.16	16.24	1.27	19.25	16.73	1.37	20.03	16.08	1.39	21.41	16.24	1.40	22.49	16.56	1.41
	80	16.66	15.08	1.03	17.74	15.98	1.31	18.82	16.49	1.40	19.60	15.86	1.43	20.98	16.04	1.45	22.07	16.37	1.47
	85	16.24	14.81	1.17	17.32	15.71	1.42	18.40	16.23	1.51	19.18	15.62	1.54	20.55	15.82	1.56	21.63	16.16	1.59
	90	15.82	14.53	1.30	16.90	15.44	1.54	17.97	15.97	1.61	18.75	15.38	1.64	20.12	15.59	1.67	21.20	15.95	1.70
	95	15.37	14.38	1.44	16.44	15.30	1.64	17.51	15.85	1.70	18.00	15.05	1.67	19.65	15.51	1.75	20.72	15.88	1.79
	100	14.99	14.00	1.52	16.07	14.91	1.67	17.14	15.47	1.71	17.77	14.81	1.70	19.28	15.17	1.75	20.35	15.55	1.79
105	14.62	13.61	1.59	15.69	14.53	1.70	16.76	15.09	1.72	17.54	14.58	1.73	18.90	14.84	1.75	19.97	15.23	1.79	
110	14.24	13.14	1.54	15.32	14.06	1.61	16.39	14.63	1.60	17.16	14.15	1.59	18.53	14.42	1.61	19.60	14.81	1.65	
115	13.87	12.75	1.39	14.94	13.66	1.40	16.01	14.24	1.37	16.79	13.79	1.34	18.15	14.08	1.35	19.22	14.47	1.39	
118	13.10	12.15	1.23	14.13	13.04	1.21	15.16	13.60	1.15	15.90	13.17	1.13	17.21	13.47	1.13	18.24	13.85	1.15	
122	12.84	11.95	1.18	13.86	12.83	1.14	14.87	13.38	1.09	15.60	12.97	1.05	16.90	13.26	1.05	17.91	13.64	1.08	

Heating Capacity Tables														
Model No. / Nominal Capacity (Btu/h)	Outdoor Air Temp. (°F DB)		Indoor Air Temp. °F DB / °F WB											
	°F DB	°F WB	61		64		68		70		72		75	
			TC	PI	TC	PI	TC	PI	TC	PI	TC	PI	TC	PI
2.0HP (18K)	-4	-4.4	7.63	1.10	7.10	1.14	7.19	1.15	7.02	1.16	6.87	1.16	6.58	1.21
	0	-0.4	8.66	1.11	8.16	1.16	8.15	1.17	7.97	1.18	7.82	1.19	7.49	1.24
	5	4.5	10.14	1.13	9.66	1.17	9.52	1.20	9.32	1.21	9.15	1.22	8.79	1.26
	10	9	11.12	1.14	10.67	1.18	10.44	1.22	10.23	1.23	10.05	1.24	9.66	1.28
	17	15	12.21	1.16	11.78	1.20	11.44	1.24	11.22	1.26	11.04	1.28	10.61	1.31
	20	19	12.87	1.18	12.46	1.22	12.06	1.26	11.83	1.28	11.64	1.30	11.19	1.33
	25	23	13.96	1.21	13.55	1.24	13.08	1.29	12.83	1.31	12.63	1.33	12.16	1.37
	30	28	15.06	1.24	14.59	1.28	14.10	1.32	13.83	1.35	13.63	1.37	13.13	1.41
	35	32	16.16	1.28	15.64	1.32	15.12	1.35	14.84	1.39	14.62	1.41	14.10	1.45
	40	36	16.98	1.31	16.51	1.35	15.98	1.39	15.70	1.43	15.49	1.45	14.92	1.48
	45	41	18.02	1.35	17.58	1.40	17.07	1.45	16.78	1.47	16.56	1.49	15.95	1.54
	47	43	18.42	1.37	18.02	1.42	17.50	1.47	17.21	1.49	16.98	1.51	16.37	1.56
	50	46	18.48	1.37	18.11	1.41	17.66	1.45	17.40	1.47	17.20	1.48	16.62	1.53
	55	51	18.57	1.35	18.27	1.39	17.93	1.42	17.72	1.43	17.56	1.45	17.03	1.48
	60	56	18.66	1.33	18.42	1.36	18.19	1.39	18.04	1.40	17.91	1.41	17.46	1.43
	63	59	18.71	1.33	18.51	1.35	18.35	1.37	18.23	1.38	18.12	1.38	17.70	1.40
68	64	18.77	1.32	18.60	1.33	18.51	1.35	18.42	1.35	18.34	1.36	17.96	1.37	

Remarks:
 TC: Total Capacity (Gross) (kBtu/h)
 SHC: Sensible Heat Capacity (Gross)
 PI: Power Input (including the compressor, evap. fan motor & cond. fan motor) (kW)
 DB: Dry Bulb Temperature
 WB: Wet Bulb Temperature

5. CAPACITIES AND SELECTION DATA

Cooling Capacity Table																			
Model	Outdoor Air Temp. (°F DB)	Indoor Air Temp. °F DB / °F WB																	
		68 / 57			73 / 61			77 / 64			80 / 67			86 / 72			90 / 75		
		TC	SHC	PI	TC	SHC	PI	TC	SHC	PI	TC	SHC	PI	TC	SHC	PI	TC	SHC	PI
3.0HP (24K)	5	23.77	19.04	0.92	25.25	20.11	1.24	26.73	20.70	1.34	27.79	19.88	1.36	29.68	20.05	1.36	31.15	20.43	1.36
	10	23.74	19.18	0.94	25.21	20.26	1.27	26.69	20.85	1.37	27.75	20.03	1.40	29.64	20.20	1.40	31.11	20.58	1.40
	15	23.70	19.32	0.96	25.18	20.41	1.31	26.65	21.00	1.42	27.71	20.17	1.43	29.59	20.34	1.44	31.07	20.73	1.43
	20	23.67	19.45	0.98	25.14	20.55	1.34	26.61	21.15	1.45	27.67	20.32	1.48	29.55	20.49	1.48	31.02	20.88	1.48
	25	23.64	19.59	1.02	25.10	20.70	1.37	26.57	21.30	1.49	27.63	20.46	1.51	29.51	20.63	1.51	30.98	21.02	1.51
	30	23.60	19.73	1.04	25.07	20.84	1.41	26.53	21.45	1.52	27.59	20.60	1.55	29.47	20.78	1.56	30.93	21.17	1.55
	35	23.57	19.87	1.06	25.03	20.98	1.44	26.50	21.60	1.57	27.55	20.75	1.59	29.42	20.92	1.59	30.89	21.32	1.59
	40	23.53	20.00	1.09	25.00	21.13	1.48	26.46	21.75	1.60	27.51	20.89	1.63	29.38	21.06	1.63	30.84	21.46	1.63
	45	23.50	20.14	1.12	24.96	21.27	1.51	26.42	21.90	1.64	27.47	21.03	1.66	29.34	21.21	1.67	30.80	21.61	1.66
	50	23.47	20.27	1.15	24.92	21.41	1.55	26.38	22.04	1.67	27.43	21.17	1.71	29.30	21.35	1.71	30.75	21.75	1.71
	55	23.43	20.41	1.17	24.89	21.56	1.58	26.34	22.19	1.72	27.39	21.31	1.74	29.25	21.49	1.74	30.71	21.90	1.74
	60	23.40	20.54	1.19	24.85	21.70	1.61	26.30	22.34	1.75	27.35	21.45	1.77	29.21	21.63	1.79	30.66	22.04	1.77
	65	23.36	20.67	1.23	24.81	21.84	1.65	26.27	22.48	1.79	27.31	21.59	1.82	29.17	21.77	1.82	30.62	22.19	1.82
	70	23.33	20.81	1.25	24.78	21.98	1.68	26.23	22.63	1.83	27.27	21.73	1.85	29.13	21.91	1.85	30.57	22.33	1.85
	75	22.77	20.46	1.33	24.21	21.65	1.74	25.66	22.31	1.88	26.70	21.44	1.91	28.55	21.65	1.92	29.99	22.08	1.94
	80	22.21	20.11	1.41	23.65	21.30	1.80	25.09	21.98	1.92	26.13	21.14	1.96	27.97	21.38	1.99	29.42	21.82	2.02
	85	21.65	19.75	1.60	23.09	20.95	1.95	24.53	21.64	2.07	25.57	20.83	2.11	27.40	21.09	2.14	28.84	21.54	2.18
	90	21.09	19.37	1.79	22.53	20.58	2.11	23.96	21.29	2.21	25.00	20.51	2.24	26.83	20.79	2.29	28.27	21.26	2.32
95	20.49	19.17	1.98	21.92	20.40	2.24	23.35	21.13	2.32	24.00	20.06	2.29	26.20	20.68	2.40	27.63	21.17	2.45	
100	19.99	18.66	2.08	21.42	19.88	2.29	22.85	20.62	2.35	23.69	19.75	2.32	25.70	20.23	2.40	27.13	20.73	2.45	
105	19.49	18.14	2.18	20.92	19.37	2.34	22.35	20.12	2.36	23.38	19.44	2.37	25.20	19.79	2.40	26.63	20.30	2.45	
110	18.99	17.52	2.12	20.42	18.74	2.21	21.85	19.50	2.20	22.88	18.86	2.19	24.70	19.23	2.21	26.13	19.74	2.27	
115	18.49	17.00	1.90	19.92	18.21	1.92	21.35	18.98	1.88	22.38	18.38	1.84	24.20	18.77	1.85	25.63	19.29	1.90	
118	17.47	16.20	1.68	18.84	17.38	1.66	20.21	18.13	1.58	21.20	17.56	1.55	22.95	17.96	1.55	24.32	18.47	1.58	
122	17.12	15.93	1.61	18.48	17.10	1.57	19.83	17.84	1.49	20.80	17.29	1.44	22.53	17.68	1.44	23.88	18.19	1.48	

Heating Capacity Tables														
Model No. / Nominal Capacity (Btu/h)	Outdoor Air Temp. (°F DB)		Indoor Air Temp. °F DB / °F WB											
	°F DB	°F WB	61		64		68		70		72		75	
			TC	PI	TC	PI	TC	PI	TC	PI	TC	PI	TC	PI
3.0HP (24K)	-13	-13.4	9.61	1.81	8.79	1.89	9.08	1.89	8.84	1.90	8.64	1.90	8.25	1.99
	-4	-4.4	11.33	1.84	10.55	1.92	10.68	1.93	10.43	1.94	10.21	1.95	9.77	2.03
	0	-0.4	12.87	1.87	12.12	1.94	12.11	1.97	11.84	1.99	11.61	2.00	11.13	2.08
	5	4.5	15.06	1.90	14.36	1.97	14.14	2.01	13.85	2.03	13.60	2.05	13.06	2.12
	10	9	16.53	1.92	15.86	1.99	15.51	2.04	15.19	2.06	14.94	2.09	14.35	2.15
	17	15	18.14	1.95	17.50	2.02	17.00	2.09	16.67	2.12	16.41	2.15	15.77	2.21
	20	19	19.11	1.99	18.51	2.04	17.91	2.12	17.57	2.15	17.30	2.19	16.63	2.24
	25	23	20.74	2.03	20.13	2.09	19.43	2.16	19.06	2.21	18.76	2.24	18.06	2.31
	30	28	22.38	2.09	21.68	2.15	20.94	2.22	20.55	2.26	20.25	2.31	19.50	2.36
	35	32	24.01	2.14	23.24	2.22	22.46	2.27	22.05	2.33	21.73	2.36	20.94	2.43
	40	36	25.23	2.20	24.52	2.27	23.75	2.34	23.33	2.39	23.01	2.43	22.17	2.49
	45	41	26.77	2.27	26.12	2.35	25.36	2.43	24.93	2.47	24.60	2.50	23.70	2.58
	47	43	27.37	2.31	26.77	2.38	26.00	2.46	25.57	2.50	25.23	2.54	24.31	2.61
	50	46	27.46	2.30	26.90	2.36	26.24	2.43	25.86	2.47	25.55	2.49	24.69	2.57
	55	51	27.59	2.27	27.14	2.33	26.63	2.38	26.32	2.41	26.09	2.43	25.31	2.48
60	56	27.72	2.24	27.36	2.28	27.02	2.33	26.80	2.35	26.61	2.36	25.93	2.39	
63	59	27.80	2.23	27.50	2.26	27.26	2.31	27.08	2.32	26.93	2.32	26.30	2.35	
68	64	27.88	2.22	27.64	2.24	27.51	2.27	27.36	2.27	27.25	2.28	26.68	2.31	

Remarks:
 TC: Total Capacity (Gross) (kBtu/h)
 SHC: Sensible Heat Capacity (Gross)
 PI: Power Input (including the compressor,
 evap. fan motor & cond. fan motor) (kW)
 DB: Dry Bulb Temperature
 WB: Wet Bulb Temperature

5. CAPACITIES AND SELECTION DATA

Cooling Capacity Table																			
Model	Outdoor Air Temp. (°F DB)	Indoor Air Temp. °F DB / °F WB																	
		68 / 57			73 / 61			77 / 64			80 / 67			86 / 72			90 / 75		
		TC	SHC	PI	TC	SHC	PI	TC	SHC	PI	TC	SHC	PI	TC	SHC	PI	TC	SHC	PI
4.0HP (36K)	5	35.50	28.44	1.32	37.71	30.04	1.78	39.92	30.92	1.92	41.51	29.69	1.96	44.33	29.95	1.96	46.53	30.51	1.96
	10	35.46	28.65	1.35	37.65	30.26	1.83	39.86	31.14	1.97	41.45	29.92	2.01	44.27	30.17	2.01	46.47	30.74	2.01
	15	35.40	28.86	1.38	37.61	30.48	1.87	39.80	31.37	2.04	41.39	30.13	2.06	44.20	30.38	2.07	46.41	30.96	2.06
	20	35.35	29.05	1.41	37.55	30.69	1.92	39.74	31.59	2.09	41.33	30.35	2.12	44.14	30.60	2.12	46.33	31.19	2.12
	25	35.31	29.26	1.46	37.49	30.92	1.97	39.69	31.81	2.14	41.27	30.56	2.17	44.08	30.81	2.17	46.27	31.40	2.17
	30	35.25	29.47	1.50	37.44	31.13	2.02	39.63	32.04	2.19	41.21	30.77	2.22	44.02	31.04	2.24	46.20	31.62	2.22
	35	35.20	29.68	1.53	37.38	31.34	2.07	39.58	32.26	2.25	41.15	30.99	2.29	43.94	31.25	2.29	46.14	31.84	2.29
	40	35.14	29.87	1.56	37.34	31.56	2.12	39.52	32.49	2.30	41.09	31.20	2.34	43.88	31.46	2.34	46.06	32.05	2.34
	45	35.10	30.08	1.61	37.28	31.77	2.17	39.46	32.71	2.35	41.03	31.41	2.38	43.82	31.68	2.40	46.00	32.28	2.38
	50	35.05	30.28	1.64	37.22	31.98	2.22	39.40	32.92	2.40	40.97	31.62	2.45	43.76	31.89	2.45	45.93	32.49	2.45
	55	35.00	30.48	1.68	37.18	32.20	2.27	39.34	33.14	2.47	40.91	31.83	2.50	43.69	32.10	2.50	45.87	32.71	2.50
	60	34.95	30.68	1.71	37.12	32.41	2.32	39.28	33.37	2.52	40.85	32.04	2.55	43.63	32.31	2.57	45.79	32.92	2.55
	65	34.89	30.87	1.76	37.06	32.62	2.37	39.24	33.58	2.57	40.79	32.25	2.61	43.57	32.52	2.61	45.73	33.14	2.61
	70	34.85	31.08	1.79	37.01	32.83	2.42	39.18	33.80	2.63	40.73	32.46	2.66	43.51	32.72	2.66	45.66	33.35	2.66
	75	34.01	30.56	1.91	36.16	32.34	2.50	38.33	33.32	2.70	39.88	32.02	2.75	42.64	32.34	2.76	44.79	32.98	2.78
	80	33.17	30.04	2.02	35.32	31.81	2.58	37.47	32.83	2.76	39.03	31.57	2.81	41.78	31.93	2.86	43.94	32.59	2.89
	85	32.34	29.50	2.30	34.49	31.29	2.80	36.64	32.32	2.98	38.19	31.11	3.03	40.92	31.50	3.08	43.08	32.17	3.12
	90	31.50	28.93	2.57	33.65	30.74	3.03	35.79	31.80	3.17	37.34	30.63	3.22	40.07	31.05	3.29	42.22	31.75	3.34
	95	30.60	28.63	2.84	32.74	30.47	3.22	34.88	31.56	3.34	35.85	29.96	3.29	39.13	30.89	3.45	41.27	31.62	3.52
	100	29.86	27.87	2.99	31.99	29.69	3.29	34.13	30.80	3.37	35.38	29.50	3.34	38.39	30.22	3.45	40.52	30.96	3.52
105	29.11	27.09	3.12	31.25	28.93	3.35	33.38	30.05	3.39	34.92	29.04	3.40	37.64	29.56	3.45	39.77	30.32	3.52	
110	28.36	26.17	3.04	30.50	27.99	3.17	32.64	29.13	3.16	34.17	28.17	3.14	36.89	28.72	3.17	39.03	29.48	3.26	
115	27.62	25.39	2.73	29.75	27.20	2.76	31.89	28.35	2.70	33.43	27.45	2.65	36.15	28.03	2.66	38.28	28.81	2.73	
118	26.09	24.20	2.42	28.14	25.96	2.38	30.19	27.08	2.27	31.66	26.23	2.22	34.28	26.83	2.22	36.32	27.59	2.27	
122	25.57	23.79	2.32	27.60	25.54	2.25	29.62	26.65	2.14	31.07	25.82	2.07	33.65	26.41	2.07	35.67	27.17	2.12	

Heating Capacity Tables														
Model No. / Nominal Capacity (Btu/h)	Outdoor Air Temp. (°F DB)		Indoor Air Temp. °F DB / °F WB											
	°F DB	°F WB	61		64		68		70		72		75	
			TC	PI	TC	PI	TC	PI	TC	PI	TC	PI	TC	PI
4.0HP 36K	-4	-4.4	15.69	2.62	14.61	2.73	14.79	2.74	14.44	2.77	14.14	2.77	13.53	2.89
	0	-0.4	17.82	2.66	16.79	2.77	16.77	2.80	16.39	2.83	16.08	2.84	15.41	2.95
	5	4.5	20.85	2.70	19.88	2.80	19.58	2.86	19.17	2.89	18.83	2.92	18.09	3.02
	10	9	22.89	2.73	21.95	2.83	21.47	2.91	21.04	2.94	20.68	2.97	19.87	3.06
	17	15	25.11	2.78	24.24	2.88	23.54	2.97	23.08	3.02	22.71	3.06	21.84	3.14
	20	19	26.47	2.83	25.63	2.91	24.80	3.02	24.33	3.06	23.95	3.11	23.03	3.19
	25	23	28.72	2.89	27.87	2.97	26.90	3.08	26.39	3.14	25.98	3.19	25.01	3.28
	30	28	30.99	2.97	30.02	3.06	29.00	3.16	28.46	3.22	28.04	3.28	27.00	3.36
	35	32	33.25	3.05	32.18	3.16	31.10	3.23	30.53	3.31	30.09	3.36	29.00	3.45
	40	36	34.94	3.13	33.95	3.23	32.88	3.33	32.30	3.41	31.86	3.45	30.70	3.55
	45	41	37.06	3.23	36.17	3.34	35.11	3.45	34.52	3.52	34.06	3.56	32.81	3.67
	47	43	37.90	3.28	37.06	3.39	36.00	3.50	35.41	3.56	34.94	3.61	33.67	3.72
	50	46	38.02	3.27	37.25	3.36	36.33	3.45	35.80	3.52	35.38	3.55	34.19	3.66
	55	51	38.20	3.23	37.57	3.31	36.88	3.39	36.45	3.42	36.12	3.45	35.04	3.53
	60	56	38.39	3.19	37.89	3.25	37.42	3.31	37.10	3.34	36.84	3.36	35.91	3.41
63	59	38.49	3.17	38.07	3.22	37.74	3.28	37.50	3.30	37.29	3.30	36.42	3.34	
68	64	38.61	3.16	38.27	3.19	38.09	3.23	37.89	3.23	37.73	3.25	36.94	3.28	

Remarks:
 TC: Total Capacity (Gross) (kBtu/h)
 SHC: Sensible Heat Capacity (Gross)
 PI: Power Input (including the compressor, evap. fan motor & cond. fan motor) (kW)
 DB: Dry Bulb Temperature
 WB: Wet Bulb Temperature

5. CAPACITIES AND SELECTION DATA

Cassette

Cooling Capacity Table																			
Model	Outdoor Air Temp. (°F DB)	Indoor Air Temp. °F DB / °F WB																	
		68 / 57			73 / 61			77 / 64			80 / 67			86 / 72			90 / 75		
		TC	SHC	PI	TC	SHC	PI	TC	SHC	PI	TC	SHC	PI	TC	SHC	PI	TC	SHC	PI
1.0HP (9K)	5	8.91	7.14	0.28	9.47	7.54	0.38	10.02	7.76	0.41	10.42	7.46	0.42	11.13	7.52	0.42	11.68	7.66	0.42
	10	8.90	7.19	0.29	9.45	7.60	0.39	10.01	7.82	0.42	10.41	7.51	0.43	11.12	7.58	0.43	11.67	7.72	0.43
	15	8.89	7.25	0.29	9.44	7.65	0.40	9.99	7.88	0.43	10.39	7.56	0.44	11.10	7.63	0.44	11.65	7.77	0.44
	20	8.88	7.29	0.30	9.43	7.71	0.41	9.98	7.93	0.44	10.38	7.62	0.45	11.08	7.68	0.45	11.63	7.83	0.45
	25	8.87	7.35	0.31	9.41	7.76	0.42	9.96	7.99	0.46	10.36	7.67	0.46	11.07	7.74	0.46	11.62	7.88	0.46
	30	8.85	7.40	0.32	9.40	7.82	0.43	9.95	8.04	0.47	10.35	7.73	0.47	11.05	7.79	0.48	11.60	7.94	0.47
	35	8.84	7.45	0.33	9.39	7.87	0.44	9.94	8.10	0.48	10.33	7.78	0.49	11.03	7.85	0.49	11.58	8.00	0.49
	40	8.82	7.50	0.33	9.38	7.92	0.45	9.92	8.16	0.49	10.32	7.83	0.50	11.02	7.90	0.50	11.57	8.05	0.50
	45	8.81	7.55	0.34	9.36	7.98	0.46	9.91	8.21	0.50	10.30	7.89	0.51	11.00	7.95	0.51	11.55	8.10	0.51
	50	8.80	7.60	0.35	9.35	8.03	0.47	9.89	8.27	0.51	10.29	7.94	0.52	10.99	8.01	0.52	11.53	8.16	0.52
	55	8.79	7.65	0.36	9.33	8.09	0.48	9.88	8.32	0.53	10.27	7.99	0.53	10.97	8.06	0.53	11.52	8.21	0.53
	60	8.78	7.70	0.36	9.32	8.14	0.49	9.86	8.38	0.54	10.26	8.04	0.54	10.95	8.11	0.55	11.50	8.27	0.54
	65	8.76	7.75	0.37	9.30	8.19	0.50	9.85	8.43	0.55	10.24	8.10	0.56	10.94	8.16	0.56	11.48	8.32	0.56
	70	8.75	7.80	0.38	9.29	8.24	0.51	9.84	8.49	0.56	10.23	8.15	0.57	10.92	8.22	0.57	11.46	8.37	0.57
	75	8.54	7.67	0.41	9.08	8.12	0.53	9.62	8.37	0.57	10.01	8.04	0.58	10.71	8.12	0.59	11.25	8.28	0.59
	80	8.33	7.54	0.43	8.87	7.99	0.55	9.41	8.24	0.59	9.80	7.93	0.60	10.49	8.02	0.61	11.03	8.18	0.62
	85	8.12	7.41	0.49	8.66	7.86	0.60	9.20	8.12	0.63	9.59	7.81	0.64	10.28	7.91	0.65	10.82	8.08	0.67
	90	7.91	7.26	0.55	8.45	7.72	0.64	8.99	7.98	0.68	9.38	7.69	0.69	10.06	7.80	0.70	10.60	7.97	0.71
	95	7.68	7.19	0.61	8.22	7.65	0.69	8.76	7.92	0.71	9.00	7.52	0.70	9.83	7.76	0.74	10.36	7.94	0.75
	100	7.50	7.00	0.64	8.03	7.46	0.70	8.57	7.73	0.72	8.88	7.41	0.71	9.64	7.59	0.74	10.17	7.77	0.75
105	7.31	6.80	0.67	7.85	7.26	0.71	8.38	7.55	0.72	8.77	7.29	0.72	9.45	7.42	0.74	9.99	7.61	0.75	
110	7.12	6.57	0.65	7.66	7.03	0.68	8.19	7.31	0.67	8.58	7.07	0.67	9.26	7.21	0.68	9.80	7.40	0.69	
115	6.93	6.38	0.58	7.47	6.83	0.59	8.01	7.12	0.57	8.39	6.89	0.56	9.08	7.04	0.57	9.61	7.23	0.58	
118	6.55	6.08	0.51	7.07	6.52	0.51	7.58	6.80	0.48	7.95	6.59	0.47	8.61	6.74	0.47	9.12	6.93	0.48	
122	6.42	5.97	0.49	6.93	6.41	0.48	7.44	6.69	0.46	7.80	6.48	0.44	8.45	6.63	0.44	8.96	6.82	0.45	

Heating Capacity Tables															
Model No. / Nominal Capacity (Btu/h)	Outdoor Air Temp. (°F DB)		Indoor Air Temp. °F DB / °F WB												
	°F DB	°F WB	61		64		68		70		72		75		
			TC	PI	TC	PI	TC	PI	TC	PI	TC	PI	TC	PI	
1.0HP (9K)	-4	-4.4	4.36	0.60	4.06	0.62	4.11	0.63	4.01	0.63	3.93	0.63	3.76	0.66	
	0	-0.4	4.95	0.61	4.66	0.63	4.66	0.64	4.55	0.65	4.47	0.65	4.28	0.68	
	5	4.5	5.79	0.62	5.52	0.64	5.44	0.65	5.33	0.66	5.23	0.67	5.02	0.69	
	10	9	6.36	0.63	6.10	0.65	5.96	0.66	5.84	0.67	5.74	0.68	5.52	0.70	
	17	15	6.98	0.64	6.73	0.66	6.54	0.68	6.41	0.69	6.31	0.70	6.07	0.72	
	20	19	7.35	0.65	7.12	0.66	6.89	0.69	6.76	0.70	6.65	0.71	6.40	0.73	
	25	23	7.98	0.66	7.74	0.68	7.47	0.70	7.33	0.72	7.22	0.73	6.95	0.75	
	30	28	8.61	0.68	8.34	0.70	8.05	0.72	7.91	0.74	7.79	0.75	7.50	0.77	
	35	32	9.23	0.70	8.94	0.72	8.64	0.74	8.48	0.76	8.36	0.77	8.05	0.79	
	40	36	9.70	0.71	9.43	0.74	9.13	0.76	8.97	0.78	8.85	0.79	8.53	0.81	
	45	41	10.30	0.74	10.05	0.76	9.75	0.79	9.59	0.80	9.46	0.81	9.11	0.84	
	47	43	10.53	0.75	10.30	0.78	10.00	0.80	9.84	0.81	9.70	0.83	9.35	0.85	
	50	46	10.56	0.75	10.35	0.77	10.09	0.79	9.95	0.80	9.83	0.81	9.50	0.84	
	55	51	10.61	0.74	10.44	0.76	10.24	0.78	10.12	0.78	10.03	0.79	9.73	0.81	
	60	56	10.66	0.73	10.52	0.74	10.39	0.76	10.31	0.76	10.23	0.77	9.97	0.78	
63	59	10.69	0.73	10.58	0.74	10.48	0.75	10.42	0.75	10.36	0.75	10.12	0.76		
68	64	10.72	0.72	10.63	0.73	10.58	0.74	10.52	0.74	10.48	0.74	10.26	0.75		

Remarks:
 TC: Total Capacity (Gross) (kBtu/h)
 SHC: Sensible Heat Capacity (Gross)
 PI: Power Input (including the compressor, evap. fan motor & cond. fan motor) (kW)
 DB: Dry Bulb Temperature
 WB: Wet Bulb Temperature

5. CAPACITIES AND SELECTION DATA

Cooling Capacity Table																			
Model	Outdoor Air Temp. (°F DB)	Indoor Air Temp. °F DB / °F WB																	
		68 / 57			73 / 61			77 / 64			80 / 67			86 / 72			90 / 75		
		TC	SHC	PI	TC	SHC	PI	TC	SHC	PI	TC	SHC	PI	TC	SHC	PI	TC	SHC	PI
1.5HP (12K)	5	11.89	9.52	0.38	12.63	10.06	0.52	13.37	10.35	0.56	13.90	9.94	0.57	14.84	10.03	0.57	15.58	10.22	0.57
	10	11.87	9.59	0.39	12.61	10.13	0.53	13.35	10.43	0.58	13.88	10.02	0.59	14.82	10.10	0.59	15.56	10.29	0.59
	15	11.85	9.66	0.40	12.59	10.21	0.55	13.33	10.50	0.60	13.86	10.09	0.60	14.80	10.17	0.60	15.54	10.37	0.60
	20	11.84	9.73	0.41	12.57	10.28	0.56	13.31	10.58	0.61	13.84	10.16	0.62	14.78	10.25	0.62	15.51	10.44	0.62
	25	11.82	9.80	0.43	12.55	10.35	0.58	13.29	10.65	0.62	13.82	10.23	0.63	14.76	10.32	0.63	15.49	10.51	0.63
	30	11.80	9.87	0.44	12.54	10.42	0.59	13.27	10.73	0.64	13.80	10.30	0.65	14.74	10.39	0.65	15.47	10.59	0.65
	35	11.79	9.94	0.45	12.52	10.49	0.60	13.25	10.80	0.66	13.78	10.38	0.67	14.71	10.46	0.67	15.45	10.66	0.67
	40	11.77	10.00	0.46	12.50	10.57	0.62	13.23	10.88	0.67	13.76	10.45	0.68	14.69	10.53	0.68	15.42	10.73	0.68
	45	11.75	10.07	0.47	12.48	10.64	0.63	13.21	10.95	0.69	13.74	10.52	0.70	14.67	10.61	0.70	15.40	10.81	0.70
	50	11.74	10.14	0.48	12.46	10.71	0.65	13.19	11.02	0.70	13.72	10.59	0.72	14.65	10.68	0.72	15.38	10.88	0.72
	55	11.72	10.21	0.49	12.45	10.78	0.66	13.17	11.10	0.72	13.70	10.66	0.73	14.63	10.75	0.73	15.36	10.95	0.73
	60	11.70	10.27	0.50	12.43	10.85	0.68	13.15	11.17	0.73	13.68	10.73	0.74	14.61	10.82	0.75	15.33	11.02	0.74
	65	11.68	10.34	0.51	12.41	10.92	0.69	13.14	11.24	0.75	13.66	10.80	0.76	14.59	10.89	0.76	15.31	11.10	0.76
	70	11.67	10.41	0.52	12.39	10.99	0.71	13.12	11.32	0.77	13.64	10.87	0.78	14.57	10.96	0.78	15.29	11.17	0.78
	75	11.39	10.23	0.56	12.11	10.83	0.73	12.83	11.16	0.79	13.35	10.72	0.80	14.28	10.83	0.81	15.00	11.04	0.81
	80	11.11	10.06	0.59	11.83	10.65	0.75	12.55	10.99	0.81	13.07	10.57	0.82	13.99	10.69	0.84	14.71	10.91	0.84
	85	10.83	9.88	0.67	11.55	10.48	0.82	12.27	10.82	0.87	12.79	10.42	0.88	13.70	10.55	0.90	14.42	10.77	0.91
	90	10.55	9.69	0.75	11.27	10.29	0.88	11.98	10.65	0.93	12.50	10.26	0.94	13.42	10.40	0.96	14.14	10.63	0.97
	95	10.25	9.59	0.83	10.96	10.20	0.94	11.68	10.57	0.97	12.00	10.03	0.96	13.10	10.34	1.01	13.82	10.59	1.03
	100	10.00	9.33	0.87	10.71	9.94	0.96	11.43	10.31	0.98	11.85	9.88	0.97	12.85	10.12	1.01	13.57	10.37	1.03
105	9.75	9.07	0.91	10.46	9.69	0.98	11.18	10.06	0.99	11.69	9.72	0.99	12.60	9.90	1.01	13.32	10.15	1.03	
110	9.50	8.76	0.89	10.21	9.37	0.93	10.93	9.75	0.92	11.44	9.43	0.92	12.35	9.62	0.93	13.07	9.87	0.95	
115	9.25	8.50	0.80	9.96	9.11	0.81	10.68	9.49	0.79	11.19	9.19	0.77	12.10	9.39	0.78	12.82	9.65	0.80	
118	8.74	8.10	0.71	9.42	8.69	0.70	10.11	9.07	0.66	10.60	8.78	0.65	11.48	8.98	0.65	12.16	9.24	0.66	
122	8.56	7.97	0.68	9.24	8.55	0.66	9.92	8.92	0.62	10.40	8.65	0.60	11.27	8.84	0.60	11.94	9.10	0.62	

Heating Capacity Tables														
Model No. / Nominal Capacity (Btu/h)	Outdoor Air Temp. (°F DB)		Indoor Air Temp. °F DB / °F WB											
	°F DB	°F WB	61		64		68		70		72		75	
			TC	PI	TC	PI	TC	PI	TC	PI	TC	PI	TC	PI
1.5HP (12K)	-4	-4.4	5.23	0.69	4.87	0.72	4.93	0.73	4.81	0.73	4.71	0.73	4.51	0.76
	0	-0.4	5.94	0.70	5.60	0.73	5.59	0.74	5.46	0.75	5.36	0.75	5.14	0.78
	5	4.5	6.95	0.72	6.63	0.74	6.53	0.76	6.39	0.76	6.28	0.77	6.03	0.80
	10	9	7.63	0.72	7.32	0.75	7.16	0.77	7.01	0.78	6.89	0.79	6.62	0.81
	17	15	8.37	0.74	8.08	0.76	7.85	0.79	7.69	0.80	7.57	0.81	7.28	0.83
	20	19	8.82	0.75	8.54	0.77	8.27	0.80	8.11	0.81	7.98	0.82	7.68	0.84
	25	23	9.57	0.76	9.29	0.79	8.97	0.81	8.80	0.83	8.66	0.84	8.34	0.87
	30	28	10.33	0.79	10.01	0.81	9.67	0.84	9.49	0.85	9.35	0.87	9.00	0.89
	35	32	11.08	0.81	10.73	0.84	10.37	0.86	10.18	0.88	10.03	0.89	9.67	0.91
	40	36	11.65	0.83	11.32	0.86	10.96	0.88	10.77	0.90	10.62	0.91	10.23	0.94
	45	41	12.35	0.86	12.06	0.88	11.70	0.91	11.51	0.93	11.35	0.94	10.94	0.97
	47	43	12.63	0.87	12.35	0.90	12.00	0.93	11.80	0.94	11.65	0.95	11.22	0.98
	50	46	12.67	0.86	12.42	0.89	12.11	0.91	11.93	0.93	11.79	0.94	11.40	0.97
	55	51	12.73	0.86	12.52	0.88	12.29	0.90	12.15	0.91	12.04	0.91	11.68	0.93
	60	56	12.80	0.84	12.63	0.86	12.47	0.88	12.37	0.88	12.28	0.89	11.97	0.90
63	59	12.83	0.84	12.69	0.85	12.58	0.87	12.50	0.87	12.43	0.87	12.14	0.88	
68	64	12.87	0.84	12.76	0.84	12.70	0.86	12.63	0.86	12.58	0.86	12.31	0.87	

Remarks:
 TC: Total Capacity (Gross) (kBtu/h)
 SHC: Sensible Heat Capacity (Gross)
 PI: Power Input (including the compressor, evap. fan motor & cond. fan motor) (kW)
 DB: Dry Bulb Temperature
 WB: Wet Bulb Temperature

5. CAPACITIES AND SELECTION DATA

Cooling Capacity Table																			
Model	Outdoor Air Temp. (°F DB)	Indoor Air Temp. °F DB / °F WB																	
		68 / 57			73 / 61			77 / 64			80 / 67			86 / 72			90 / 75		
		TC	SHC	PI	TC	SHC	PI	TC	SHC	PI	TC	SHC	PI	TC	SHC	PI	TC	SHC	PI
2.0HP (18K)	5	17.83	14.28	0.57	18.94	15.08	0.77	20.05	15.53	0.83	20.84	14.91	0.84	22.26	15.04	0.84	23.36	15.32	0.84
	10	17.81	14.39	0.58	18.91	15.20	0.79	20.02	15.64	0.85	20.81	15.02	0.87	22.23	15.15	0.87	23.33	15.44	0.87
	15	17.78	14.49	0.60	18.89	15.31	0.81	19.99	15.75	0.88	20.78	15.13	0.89	22.19	15.26	0.89	23.30	15.55	0.89
	20	17.75	14.59	0.61	18.86	15.41	0.83	19.96	15.86	0.90	20.75	15.24	0.92	22.16	15.37	0.92	23.27	15.66	0.92
	25	17.73	14.69	0.63	18.83	15.53	0.85	19.93	15.98	0.92	20.72	15.35	0.94	22.13	15.47	0.94	23.24	15.77	0.94
	30	17.70	14.80	0.65	18.80	15.63	0.87	19.90	16.09	0.94	20.69	15.45	0.96	22.10	15.59	0.97	23.20	15.88	0.96
	35	17.68	14.90	0.66	18.77	15.74	0.89	19.88	16.20	0.97	20.66	15.56	0.99	22.07	15.69	0.99	23.17	15.99	0.99
	40	17.65	15.00	0.67	18.75	15.85	0.92	19.85	16.31	0.99	20.63	15.67	1.01	22.04	15.80	1.01	23.13	16.10	1.01
	45	17.63	15.11	0.70	18.72	15.95	0.94	19.82	16.43	1.02	20.60	15.77	1.03	22.01	15.91	1.04	23.10	16.21	1.03
	50	17.60	15.20	0.71	18.69	16.06	0.96	19.79	16.53	1.04	20.57	15.88	1.06	21.98	16.01	1.06	23.06	16.31	1.06
	55	17.57	15.31	0.72	18.67	16.17	0.98	19.76	16.64	1.07	20.54	15.98	1.08	21.94	16.12	1.08	23.03	16.43	1.08
	60	17.55	15.41	0.74	18.64	16.28	1.00	19.73	16.76	1.09	20.51	16.09	1.10	21.91	16.22	1.11	23.00	16.53	1.10
	65	17.52	15.50	0.76	18.61	16.38	1.02	19.70	16.86	1.11	20.48	16.19	1.13	21.88	16.33	1.13	22.97	16.64	1.13
	70	17.50	15.61	0.77	18.59	16.49	1.04	19.67	16.97	1.14	20.45	16.30	1.15	21.85	16.43	1.15	22.93	16.75	1.15
	75	17.08	15.35	0.82	18.16	16.24	1.08	19.25	16.73	1.16	20.03	16.08	1.19	21.41	16.24	1.19	22.49	16.56	1.20
	80	16.66	15.08	0.87	17.74	15.98	1.11	18.82	16.49	1.19	19.60	15.86	1.21	20.98	16.04	1.24	22.07	16.37	1.25
	85	16.24	14.81	0.99	17.32	15.71	1.21	18.40	16.23	1.29	19.18	15.62	1.31	20.55	15.82	1.33	21.63	16.16	1.35
	90	15.82	14.53	1.11	16.90	15.44	1.31	17.97	15.97	1.37	18.75	15.38	1.39	20.12	15.59	1.42	21.20	15.95	1.44
	95	15.37	14.38	1.23	16.44	15.30	1.39	17.51	15.85	1.44	18.00	15.05	1.42	19.65	15.51	1.49	20.72	15.88	1.52
	100	14.99	14.00	1.29	16.07	14.91	1.42	17.14	15.47	1.46	17.77	14.81	1.44	19.28	15.17	1.49	20.35	15.55	1.52
105	14.62	13.61	1.35	15.69	14.53	1.45	16.76	15.09	1.46	17.54	14.58	1.47	18.90	14.84	1.49	19.97	15.23	1.52	
110	14.24	13.14	1.31	15.32	14.06	1.37	16.39	14.63	1.36	17.16	14.15	1.36	18.53	14.42	1.37	19.60	14.81	1.41	
115	13.87	12.75	1.18	14.94	13.66	1.19	16.01	14.24	1.16	16.79	13.79	1.14	18.15	14.08	1.15	19.22	14.47	1.18	
118	13.10	12.15	1.04	14.13	13.04	1.03	15.16	13.60	0.98	15.90	13.17	0.96	17.21	13.47	0.96	18.24	13.85	0.98	
122	12.84	11.95	1.00	13.86	12.83	0.97	14.87	13.38	0.92	15.60	12.97	0.89	16.90	13.26	0.89	17.91	13.64	0.92	

Heating Capacity Tables														
Model No. / Nominal Capacity (Btu/h)	Outdoor Air Temp. (°F DB)		Indoor Air Temp. °F DB / °F WB											
	°F DB	°F WB	61		64		68		70		72		75	
			TC	PI	TC	PI	TC	PI	TC	PI	TC	PI	TC	PI
2.0HP (18K)	-4	-4.4	8.19	1.05	7.63	1.10	7.73	1.10	7.54	1.11	7.38	1.12	7.07	1.16
	0	-0.4	9.31	1.07	8.77	1.11	8.76	1.13	8.56	1.14	8.40	1.15	8.05	1.19
	5	4.5	10.89	1.09	10.38	1.13	10.23	1.15	10.01	1.16	9.83	1.18	9.44	1.21
	10	9	11.95	1.10	11.46	1.14	11.21	1.17	10.99	1.18	10.80	1.20	10.38	1.23
	17	15	13.12	1.12	12.66	1.16	12.29	1.20	12.05	1.21	11.86	1.23	11.40	1.27
	20	19	13.82	1.14	13.38	1.17	12.95	1.21	12.70	1.23	12.51	1.25	12.03	1.28
	25	23	15.00	1.16	14.55	1.20	14.05	1.24	13.78	1.27	13.57	1.28	13.06	1.32
	30	28	16.18	1.20	15.68	1.23	15.14	1.27	14.86	1.30	14.64	1.32	14.10	1.35
	35	32	17.36	1.23	16.81	1.27	16.24	1.30	15.94	1.33	15.71	1.35	15.14	1.39
	40	36	18.25	1.26	17.73	1.30	17.17	1.34	16.87	1.37	16.64	1.39	16.03	1.43
	45	41	19.35	1.30	18.89	1.35	18.33	1.39	18.03	1.42	17.79	1.44	17.14	1.48
	47	43	19.79	1.32	19.35	1.37	18.80	1.41	18.49	1.44	18.25	1.45	17.58	1.50
	50	46	19.85	1.32	19.45	1.35	18.97	1.39	18.70	1.42	18.48	1.43	17.85	1.47
	55	51	19.95	1.30	19.62	1.33	19.26	1.37	19.03	1.38	18.86	1.39	18.30	1.42
	60	56	20.05	1.28	19.79	1.31	19.54	1.33	19.38	1.35	19.24	1.35	18.75	1.37
63	59	20.10	1.28	19.88	1.30	19.71	1.32	19.58	1.33	19.47	1.33	19.02	1.35	
68	64	20.16	1.27	19.98	1.28	19.89	1.30	19.79	1.30	19.70	1.31	19.29	1.32	

Remarks:
 TC: Total Capacity (Gross) (kBtu/h)
 SHC: Sensible Heat Capacity (Gross)
 PI: Power Input (including the compressor,
 evap. fan motor & cond. fan motor) (kW)
 DB: Dry Bulb Temperature
 WB: Wet Bulb Temperature

5. CAPACITIES AND SELECTION DATA

Cooling Capacity Table																			
Model	Outdoor Air Temp. (°F DB)	Indoor Air Temp. °F DB / °F WB																	
		68 / 57			73 / 61			77 / 64			80 / 67			86 / 72			90 / 75		
		TC	SHC	PI	TC	SHC	PI	TC	SHC	PI	TC	SHC	PI	TC	SHC	PI	TC	SHC	PI
3.0HP (24K)	5	23.77	19.04	0.77	25.25	20.11	1.04	26.73	20.70	1.12	27.79	19.88	1.14	29.68	20.05	1.14	31.15	20.43	1.14
	10	23.74	19.18	0.79	25.21	20.26	1.07	26.69	20.85	1.15	27.75	20.03	1.17	29.64	20.20	1.17	31.11	20.58	1.17
	15	23.70	19.32	0.81	25.18	20.41	1.09	26.65	21.00	1.19	27.71	20.17	1.20	29.59	20.34	1.21	31.07	20.73	1.20
	20	23.67	19.45	0.83	25.14	20.55	1.12	26.61	21.15	1.22	27.67	20.32	1.24	29.55	20.49	1.24	31.02	20.88	1.24
	25	23.64	19.59	0.85	25.10	20.70	1.15	26.57	21.30	1.25	27.63	20.46	1.27	29.51	20.63	1.27	30.98	21.02	1.27
	30	23.60	19.73	0.87	25.07	20.84	1.18	26.53	21.45	1.28	27.59	20.60	1.30	29.47	20.78	1.31	30.93	21.17	1.30
	35	23.57	19.87	0.89	25.03	20.98	1.21	26.50	21.60	1.32	27.55	20.75	1.33	29.42	20.92	1.33	30.89	21.32	1.33
	40	23.53	20.00	0.91	25.00	21.13	1.24	26.46	21.75	1.34	27.51	20.89	1.36	29.38	21.06	1.36	30.84	21.46	1.36
	45	23.50	20.14	0.94	24.96	21.27	1.27	26.42	21.90	1.37	27.47	21.03	1.39	29.34	21.21	1.40	30.80	21.61	1.39
	50	23.47	20.27	0.96	24.92	21.41	1.30	26.38	22.04	1.40	27.43	21.17	1.43	29.30	21.35	1.43	30.75	21.75	1.43
	55	23.43	20.41	0.98	24.89	21.56	1.32	26.34	22.19	1.44	27.39	21.31	1.46	29.25	21.49	1.46	30.71	21.90	1.46
	60	23.40	20.54	1.00	24.85	21.70	1.35	26.30	22.34	1.47	27.35	21.45	1.49	29.21	21.63	1.50	30.66	22.04	1.49
	65	23.36	20.67	1.03	24.81	21.84	1.38	26.27	22.48	1.50	27.31	21.59	1.53	29.17	21.77	1.53	30.62	22.19	1.53
	70	23.33	20.81	1.05	24.78	21.98	1.41	26.23	22.63	1.54	27.27	21.73	1.56	29.13	21.91	1.56	30.57	22.33	1.56
	75	22.77	20.46	1.11	24.21	21.65	1.46	25.66	22.31	1.57	26.70	21.44	1.60	28.55	21.65	1.61	29.99	22.08	1.62
	80	22.21	20.11	1.18	23.65	21.30	1.51	25.09	21.98	1.61	26.13	21.14	1.64	27.97	21.38	1.67	29.42	21.82	1.69
	85	21.65	19.75	1.34	23.09	20.95	1.63	24.53	21.64	1.74	25.57	20.83	1.77	27.40	21.09	1.80	28.84	21.54	1.82
	90	21.09	19.37	1.50	22.53	20.58	1.77	23.96	21.29	1.85	25.00	20.51	1.88	26.83	20.79	1.92	28.27	21.26	1.95
95	20.49	19.17	1.66	21.92	20.40	1.88	23.35	21.13	1.95	24.00	20.06	1.92	26.20	20.68	2.02	27.63	21.17	2.05	
100	19.99	18.66	1.75	21.42	19.88	1.92	22.85	20.62	1.97	23.69	19.75	1.95	25.70	20.23	2.02	27.13	20.73	2.05	
105	19.49	18.14	1.82	20.92	19.37	1.96	22.35	20.12	1.98	23.38	19.44	1.99	25.20	19.79	2.02	26.63	20.30	2.05	
110	18.99	17.52	1.78	20.42	18.74	1.85	21.85	19.50	1.84	22.88	18.86	1.83	24.70	19.23	1.85	26.13	19.74	1.90	
115	18.49	17.00	1.59	19.92	18.21	1.61	21.35	18.98	1.57	22.38	18.38	1.55	24.20	18.77	1.56	25.63	19.29	1.59	
118	17.47	16.20	1.41	18.84	17.38	1.39	20.21	18.13	1.32	21.20	17.56	1.30	22.95	17.96	1.30	24.32	18.47	1.32	
122	17.12	15.93	1.35	18.48	17.10	1.32	19.83	17.84	1.25	20.80	17.29	1.21	22.53	17.68	1.21	23.88	18.19	1.24	

Heating Capacity Tables														
Model No. / Nominal Capacity (Btu/h)	Outdoor Air Temp. (°F DB)		Indoor Air Temp. °F DB / °F WB											
	°F DB	°F WB	61		64		68		70		72		75	
			TC	PI	TC	PI	TC	PI	TC	PI	TC	PI	TC	PI
3.0HP (24K)	-13	-13.4	9.61	1.56	8.79	1.62	9.08	1.62	8.84	1.63	8.64	1.63	8.25	1.71
	-4	-4.4	11.33	1.58	10.55	1.65	10.68	1.66	10.43	1.67	10.21	1.67	9.77	1.75
	0	-0.4	12.87	1.60	12.12	1.67	12.11	1.69	11.84	1.71	11.61	1.72	11.13	1.78
	5	4.5	15.06	1.63	14.36	1.69	14.14	1.73	13.85	1.75	13.60	1.76	13.06	1.82
	10	9	16.53	1.65	15.86	1.71	15.51	1.75	15.19	1.77	14.94	1.79	14.35	1.85
	17	15	18.14	1.68	17.50	1.74	17.00	1.79	16.67	1.82	16.41	1.85	15.77	1.90
	20	19	19.11	1.71	18.51	1.75	17.91	1.82	17.57	1.85	17.30	1.88	16.63	1.92
	25	23	20.74	1.75	20.13	1.79	19.43	1.86	19.06	1.90	18.76	1.92	18.06	1.98
	30	28	22.38	1.79	21.68	1.85	20.94	1.91	20.55	1.94	20.25	1.98	19.50	2.03
	35	32	24.01	1.84	23.24	1.91	22.46	1.95	22.05	2.00	21.73	2.03	20.94	2.08
	40	36	25.23	1.89	24.52	1.95	23.75	2.01	23.33	2.06	23.01	2.08	22.17	2.14
	45	41	26.77	1.95	26.12	2.02	25.36	2.08	24.93	2.12	24.60	2.15	23.70	2.22
	47	43	27.37	1.98	26.77	2.05	26.00	2.11	25.57	2.15	25.23	2.18	24.31	2.25
	50	46	27.46	1.97	26.90	2.03	26.24	2.08	25.86	2.12	25.55	2.14	24.69	2.21
	55	51	27.59	1.95	27.14	2.00	26.63	2.05	26.32	2.07	26.09	2.08	25.31	2.13
60	56	27.72	1.92	27.36	1.96	27.02	2.00	26.80	2.02	26.61	2.03	25.93	2.06	
63	59	27.80	1.91	27.50	1.94	27.26	1.98	27.08	1.99	26.93	1.99	26.30	2.02	
68	64	27.88	1.91	27.64	1.92	27.51	1.95	27.36	1.95	27.25	1.96	26.68	1.98	

Remarks:
 TC: Total Capacity (Gross) (kBtu/h)
 SHC: Sensible Heat Capacity (Gross)
 PI: Power Input (including the compressor, evap. fan motor & cond. fan motor) (kW)
 DB: Dry Bulb Temperature
 WB: Wet Bulb Temperature

5. CAPACITIES AND SELECTION DATA

Cooling Capacity Table																			
Model	Outdoor Air Temp. (°F DB)	Indoor Air Temp. °F DB / °F WB																	
		68 / 57			73 / 61			77 / 64			80 / 67			86 / 72			90 / 75		
		TC	SHC	PI	TC	SHC	PI	TC	SHC	PI	TC	SHC	PI	TC	SHC	PI	TC	SHC	PI
4.0HP (36K)	5	36.09	28.91	1.29	38.33	30.53	1.74	40.58	31.43	1.89	42.19	30.18	1.92	45.06	30.44	1.92	47.29	31.02	1.92
	10	36.04	29.12	1.32	38.27	30.76	1.79	40.52	31.65	1.94	42.13	30.41	1.97	45.00	30.67	1.97	47.23	31.24	1.97
	15	35.98	29.33	1.36	38.23	30.99	1.84	40.46	31.88	2.00	42.07	30.62	2.02	44.92	30.88	2.03	47.17	31.47	2.02
	20	35.94	29.53	1.39	38.17	31.20	1.89	40.40	32.11	2.05	42.01	30.85	2.08	44.86	31.11	2.08	47.09	31.70	2.08
	25	35.89	29.74	1.44	38.11	31.43	1.94	40.34	32.34	2.10	41.95	31.06	2.13	44.80	31.32	2.13	47.03	31.91	2.13
	30	35.83	29.95	1.47	38.06	31.64	1.98	40.28	32.57	2.15	41.89	31.27	2.18	44.74	31.55	2.19	46.96	32.14	2.18
	35	35.78	30.17	1.50	38.00	31.85	2.03	40.23	32.79	2.21	41.83	31.50	2.24	44.67	31.76	2.24	46.90	32.37	2.24
	40	35.72	30.36	1.53	37.95	32.08	2.08	40.17	33.02	2.26	41.77	31.72	2.29	44.60	31.97	2.29	46.82	32.58	2.29
	45	35.68	30.58	1.58	37.89	32.29	2.13	40.11	33.25	2.31	41.70	31.93	2.34	44.54	32.20	2.36	46.76	32.81	2.34
	50	35.63	30.77	1.61	37.83	32.50	2.18	40.05	33.46	2.36	41.64	32.14	2.40	44.48	32.41	2.40	46.68	33.02	2.40
	55	35.57	30.99	1.65	37.79	32.73	2.23	39.99	33.69	2.42	41.58	32.35	2.45	44.41	32.63	2.45	46.62	33.25	2.45
	60	35.53	31.18	1.68	37.73	32.94	2.28	39.93	33.92	2.47	41.52	32.57	2.50	44.35	32.84	2.52	46.55	33.46	2.50
	65	35.47	31.38	1.73	37.67	33.16	2.32	39.88	34.13	2.52	41.46	32.78	2.57	44.29	33.05	2.57	46.49	33.69	2.57
	70	35.42	31.59	1.76	37.62	33.37	2.37	39.82	34.36	2.58	41.40	32.99	2.61	44.23	33.26	2.61	46.41	33.90	2.61
	75	34.57	31.06	1.87	36.76	32.87	2.45	38.96	33.87	2.65	40.54	32.55	2.69	43.34	32.87	2.71	45.53	33.52	2.73
	80	33.72	30.53	1.98	35.91	32.34	2.53	38.09	33.37	2.71	39.67	32.09	2.76	42.46	32.46	2.81	44.67	33.13	2.84
	85	32.87	29.98	2.26	35.06	31.81	2.74	37.24	32.85	2.92	38.82	31.62	2.97	41.60	32.02	3.02	43.78	32.70	3.07
	90	32.02	29.41	2.52	34.20	31.24	2.97	36.38	32.32	3.11	37.95	31.14	3.16	40.73	31.56	3.23	42.92	32.28	3.28
	95	31.11	29.10	2.79	33.28	30.97	3.16	35.45	32.08	3.28	36.44	30.46	3.23	39.78	31.40	3.39	41.95	32.14	3.45
	100	30.35	28.33	2.94	32.52	30.18	3.23	34.69	31.31	3.31	35.97	29.98	3.28	39.02	30.71	3.39	41.19	31.47	3.45
105	29.59	27.54	3.07	31.76	29.41	3.29	33.93	30.55	3.32	35.50	29.51	3.34	38.26	30.05	3.39	40.43	30.82	3.45	
110	28.83	26.60	2.98	31.00	28.45	3.11	33.17	29.60	3.10	34.74	28.63	3.08	37.50	29.19	3.11	39.67	29.97	3.19	
115	28.07	25.81	2.68	30.24	27.65	2.71	32.41	28.82	2.65	33.98	27.90	2.60	36.74	28.50	2.61	38.91	29.29	2.68	
118	26.52	24.59	2.37	28.60	26.39	2.34	30.68	27.52	2.23	32.19	26.66	2.18	34.84	27.27	2.18	36.92	28.04	2.23	
122	25.99	24.18	2.28	28.06	25.96	2.21	30.11	27.08	2.10	31.58	26.25	2.03	34.20	26.84	2.03	36.25	27.62	2.08	

Heating Capacity Tables														
Model No. / Nominal Capacity (Btu/h)	Outdoor Air Temp. (°F DB)		Indoor Air Temp. °F DB / °F WB											
	°F DB	°F WB	61		64		68		70		72		75	
			TC	PI	TC	PI	TC	PI	TC	PI	TC	PI	TC	PI
4.0HP (36K)	-4	-4.4	15.69	2.39	14.61	2.49	14.79	2.50	14.44	2.52	14.14	2.53	13.53	2.63
	0	-0.4	17.82	2.42	16.79	2.52	16.77	2.55	16.39	2.58	16.08	2.59	15.41	2.69
	5	4.5	20.85	2.46	19.88	2.55	19.58	2.61	19.17	2.63	18.83	2.66	18.09	2.75
	10	9	22.89	2.49	21.95	2.58	21.47	2.65	21.04	2.68	20.68	2.71	19.87	2.79
	17	15	25.11	2.53	24.24	2.62	23.54	2.71	23.08	2.75	22.71	2.79	21.84	2.86
	20	19	26.47	2.58	25.63	2.65	24.80	2.75	24.33	2.79	23.95	2.83	23.03	2.91
	25	23	28.72	2.63	27.87	2.71	26.90	2.81	26.39	2.86	25.98	2.91	25.01	2.99
	30	28	30.99	2.71	30.02	2.79	29.00	2.88	28.46	2.93	28.04	2.99	27.00	3.06
	35	32	33.25	2.78	32.18	2.88	31.10	2.95	30.53	3.02	30.09	3.06	29.00	3.15
	40	36	34.94	2.85	33.95	2.95	32.88	3.03	32.30	3.10	31.86	3.15	30.70	3.23
	45	41	37.06	2.95	36.17	3.05	35.11	3.15	34.52	3.20	34.06	3.25	32.81	3.35
	47	43	37.90	2.99	37.06	3.09	36.00	3.19	35.41	3.25	34.94	3.29	33.67	3.39
	50	46	38.02	2.98	37.25	3.06	36.33	3.15	35.80	3.20	35.38	3.23	34.19	3.33
	55	51	38.20	2.95	37.57	3.02	36.88	3.09	36.45	3.12	36.12	3.15	35.04	3.22
	60	56	38.39	2.91	37.89	2.96	37.42	3.02	37.10	3.05	36.84	3.06	35.91	3.10
63	59	38.49	2.89	38.07	2.93	37.74	2.99	37.50	3.00	37.29	3.00	36.42	3.05	
68	64	38.61	2.88	38.27	2.91	38.09	2.95	37.89	2.95	37.73	2.96	36.94	2.99	

Remarks:
 TC: Total Capacity (Gross) (kBtu/h)
 SHC: Sensible Heat Capacity (Gross)
 PI: Power Input (including the compressor,
 evap. fan motor & cond. fan motor) (kW)
 DB: Dry Bulb Temperature
 WB: Wet Bulb Temperature

5. CAPACITIES AND SELECTION DATA

5.2 Piping length correction factor

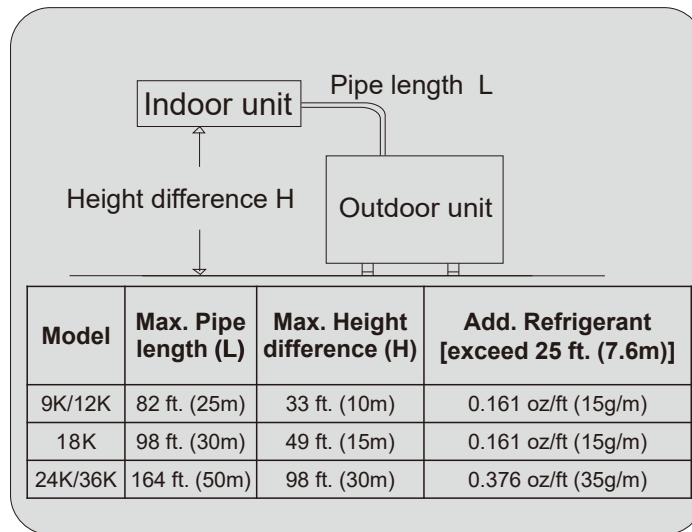

The correction factor is based on the equivalent piping length in meters (EL) and the height between outdoor and indoor units in meters (H).

H:

Height difference between indoor unit and outdoor unit (m).

- $H > 0$: Position of outdoor unit is higher than position of indoor unit (m).
- $H < 0$: Position of outdoor unit is lower than position of indoor unit (m).

L:

Actual one-way piping length between indoor unit and outdoor unit (m).

EL:

Equivalent one-way piping length between indoor unit and outdoor unit (m).

Gas Diameter (mm/inch)	9.52 (3/8')	12.7 (1/2')	15.88 (5/8')	19.05 (3/4')
90° Elbow	0.15	0.2	0.25	0.35

5. CAPACITIES AND SELECTION DATA

Cooling

Model \ EL[ft(m)]	25(7.6)	38(10)	50(15)	66(20)	82(25)	100(30)	115(35)	131(40)	148(45)	164(50)
9K	1.0	0.96	0.92	0.88	0.84	--	--	--	--	--
12K	1.0	0.98	0.96	0.95	0.94	--	--	--	--	--
18K	1.0	0.97	0.94	0.92	0.89	0.86	--	--	--	--
24K	1.0	0.99	0.98	0.97	0.97	0.96	--	--	--	--
36K	1.0	0.95	0.93	0.90	0.88	0.85	0.83	0.80	0.78	0.75

Heating

Model \ EL[ft(m)]	25(7.6)	38(10)	50(15)	66(20)	82(25)	100(30)	115(35)	131(40)	148(45)	164(50)
9K	1.0	0.97	0.94	0.92	0.89	--	--	--	--	--
12K	1.0	0.99	0.97	0.95	0.94	--	--	--	--	--
18K	1.0	0.99	0.98	0.97	0.96	0.95	--	--	--	--
24K	1.0	0.98	0.97	0.97	0.96	0.95	--	--	--	--
36K	1.0	0.94	0.91	0.88	0.85	0.82	0.79	0.76	0.73	0.70

The correction factor of height between indoor unit and outdoor unit

Height difference	16ft(5m)	33ft(10m)	108ft(30m)
Factor	0.01	0.02	0.025

To ensure correct unit selection, consider the farthest indoor unit.

NOTE:

1. Above data is assuming that the height difference between indoor unit and outdoor unit is 0m.
2. Be sure to minimize length of connection pipes to optimize performance. If the outdoor unit is installed higher or lower than the indoor unit, it is necessary to apply height correction factor additionally to length correction factor to calculate cooling/heating.

If outdoor unit is higher, correction should be applied to cooling capacity, if outdoor unit is lower, correction should be applied to heating capacity.

5. CAPACITIES AND SELECTION DATA

5.3 Correction factors according to defrosting operation

The heating capacity in the preceding paragraph excludes the condition of defrosting operation period. In consideration of defrosting operation, the heating capacity is corrected by the equation below.

Corrected heating capacity = Defrost Correction factor x unit capacity

Outdoor temperature [°F(°C)DB]	5(-15)	14(-10)	23(-5)	32(0)	44.6(7)	50(10)	59(15)
Correction factor (humidity rate 85% RH)	0.95	0.95	0.93	0.85	1.0	1.0	1.0

Correction Factor

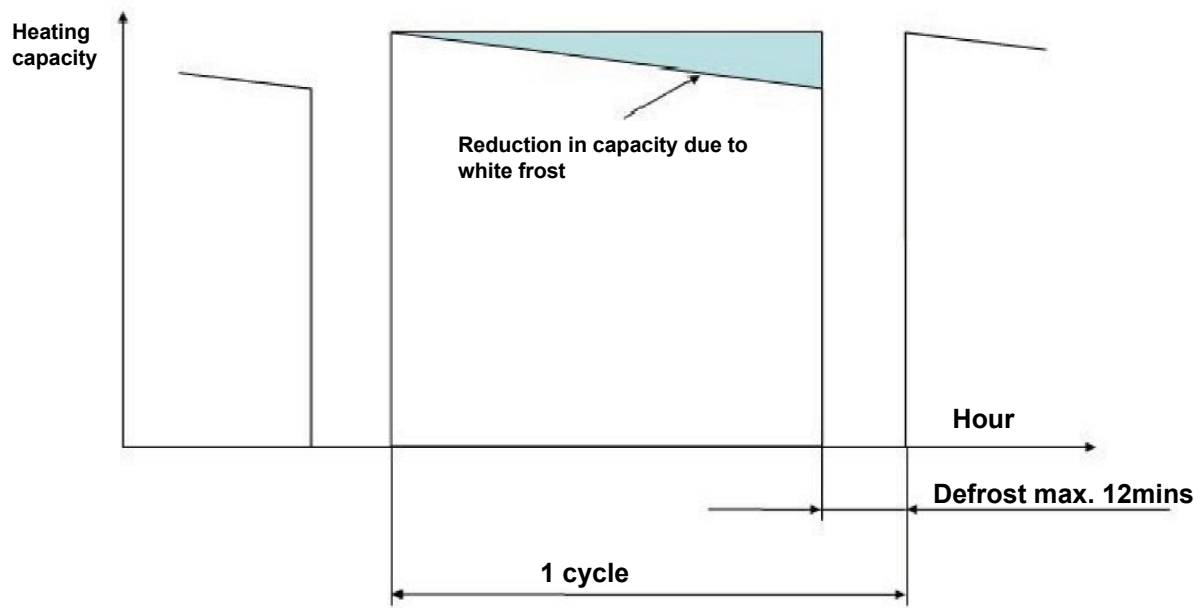

NOTE:

The correction factor is not valid for special conditions such as snowfall or operation in a transitional period.

6. SOUND PRESSURE DATA

6. Sound pressure data

Indoor unit

Duct

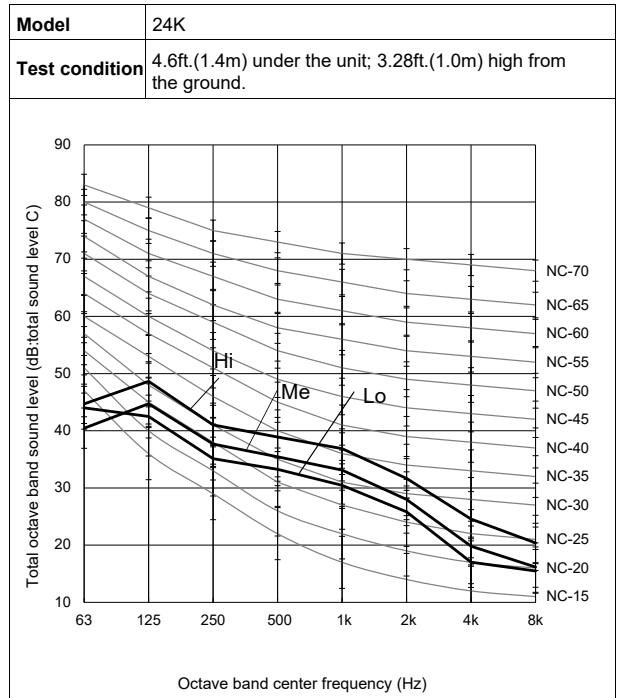
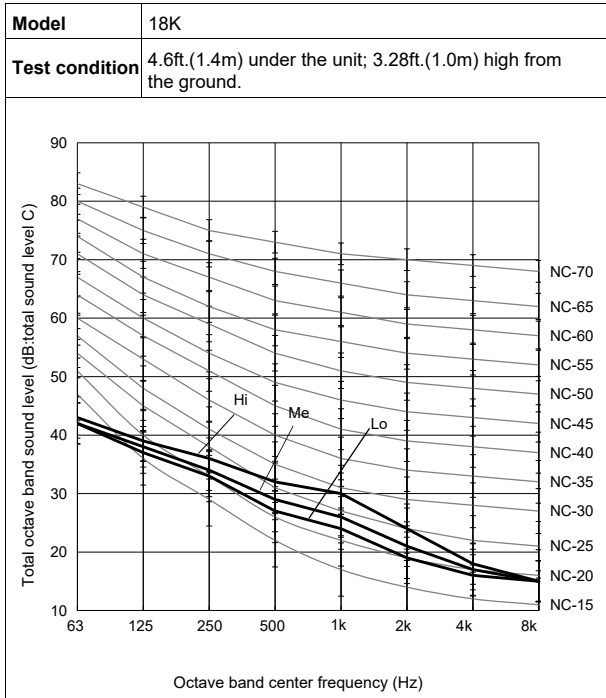
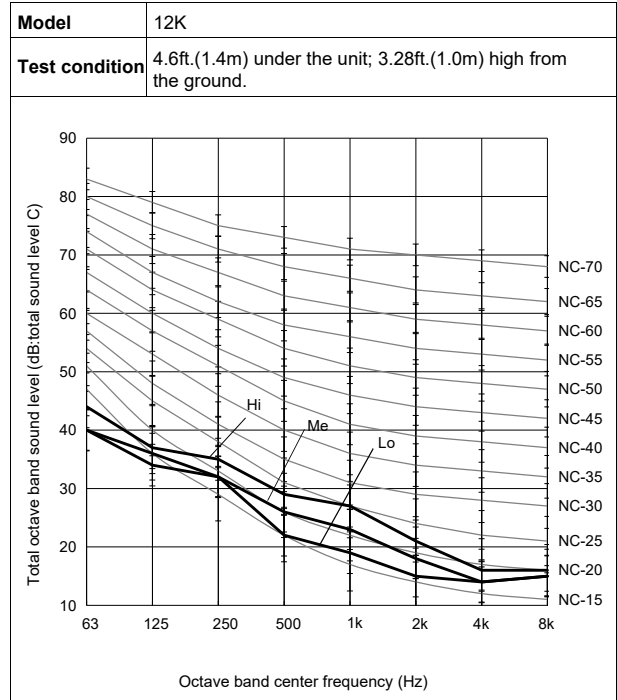
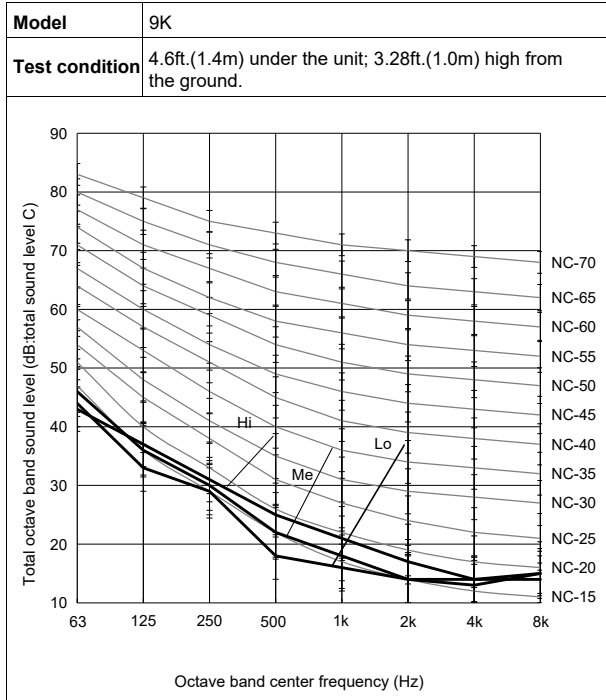

6. SOUND PRESSURE DATA

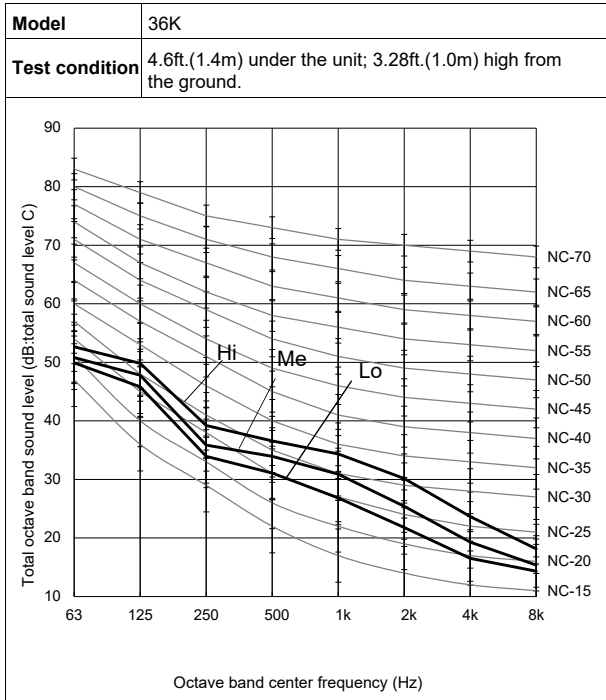

Cassette

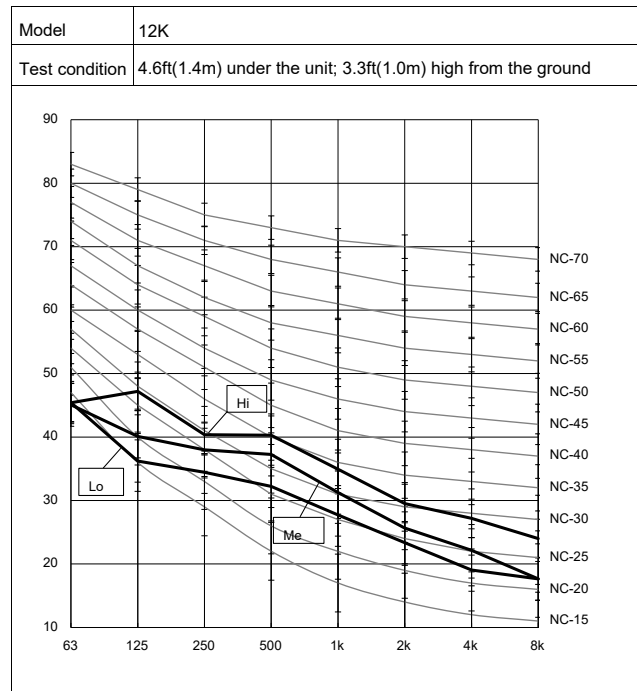
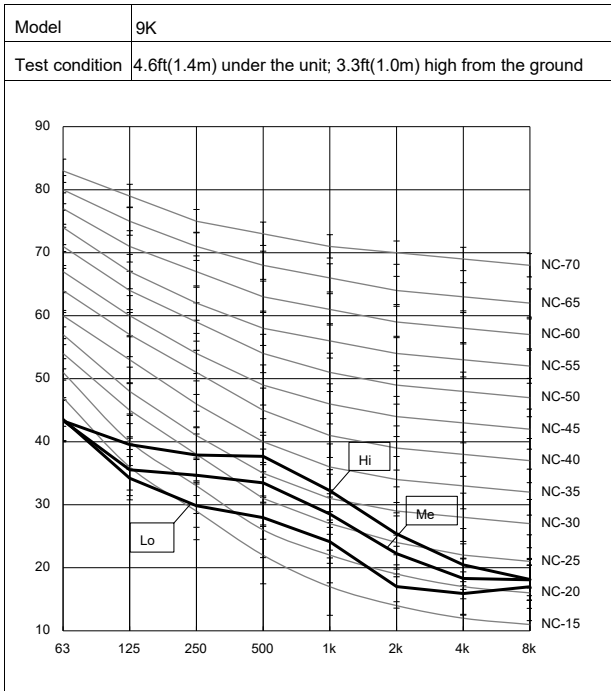

6. SOUND PRESSURE DATA

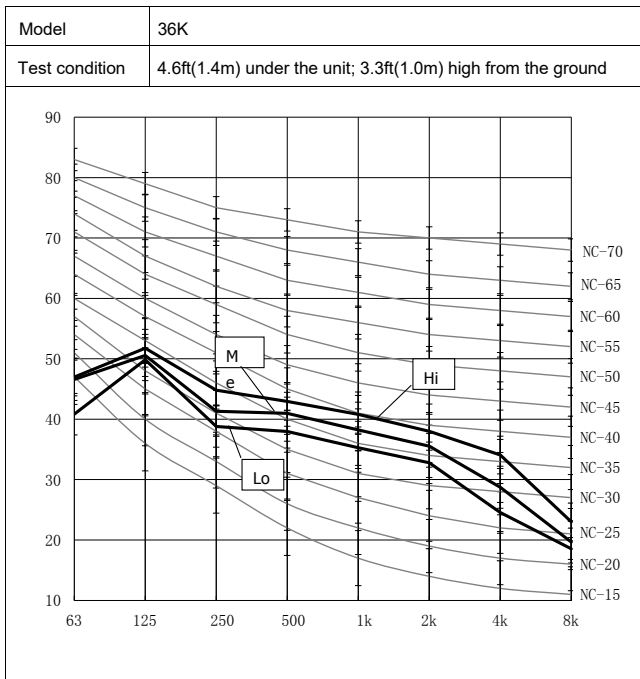
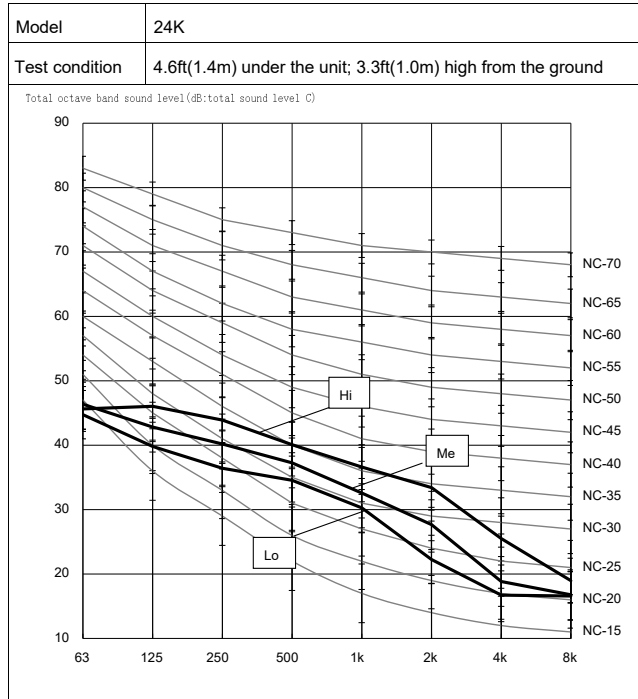
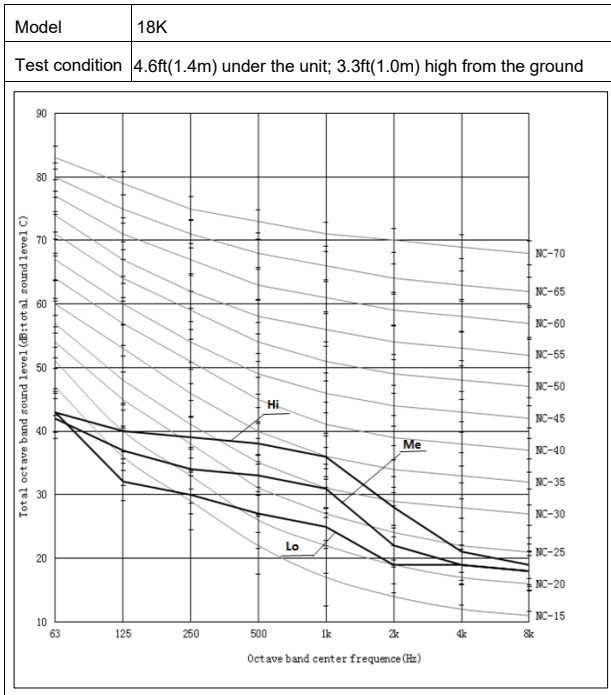

6. SOUND PRESSURE DATA

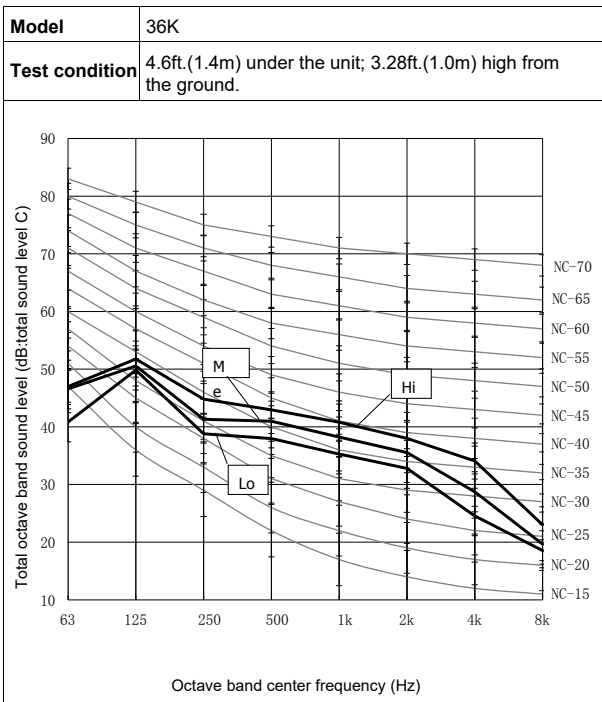

Outdoor unit

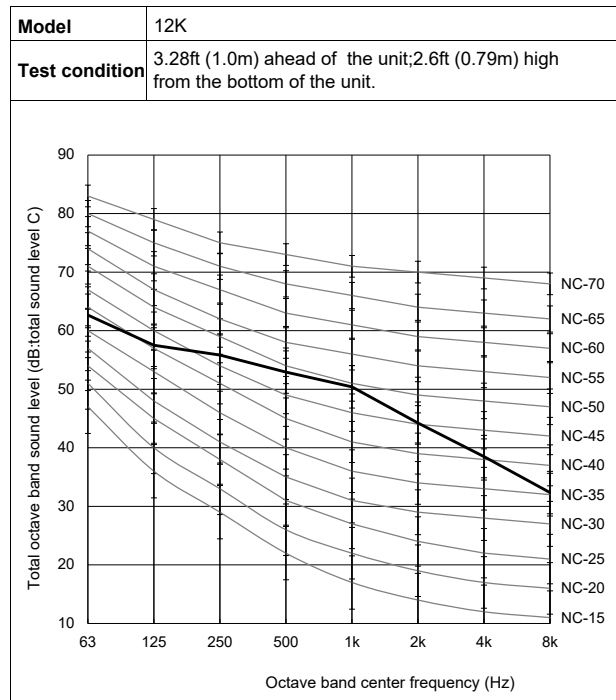
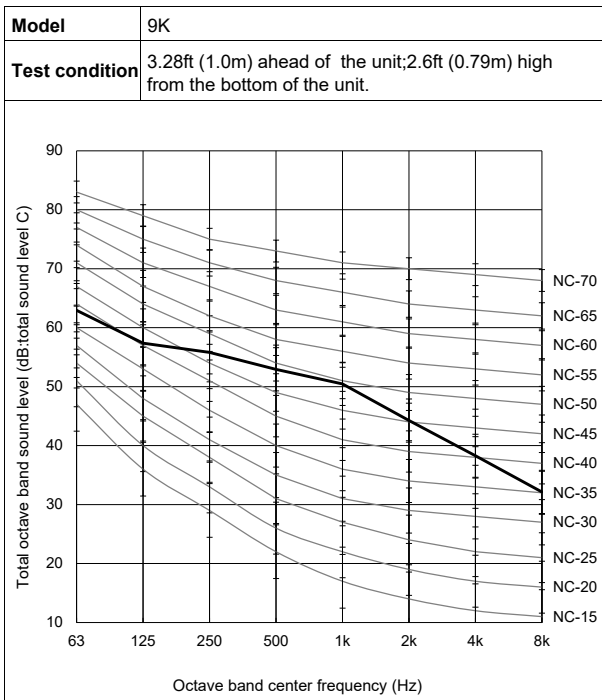

6. SOUND PRESSURE DATA

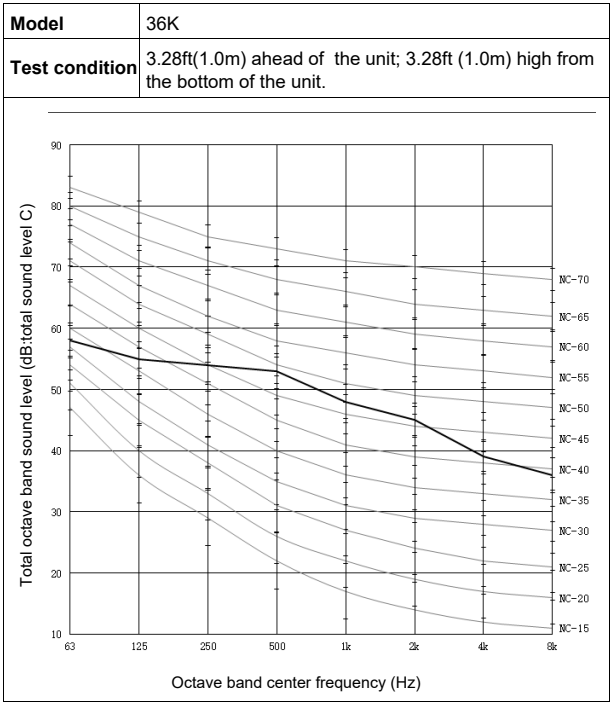
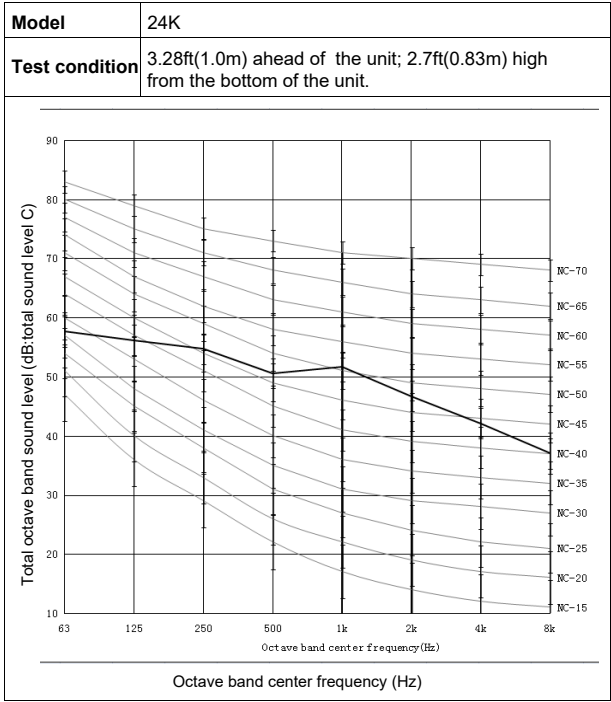
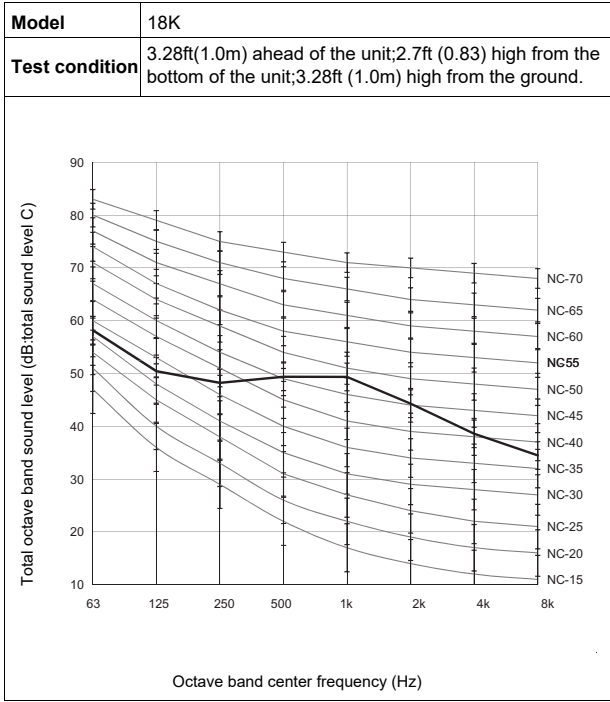

7. AIR FLOW DISTRIBUTION

7. Air flow distribution

9K

1) Cooling/Air Velocity Distribution

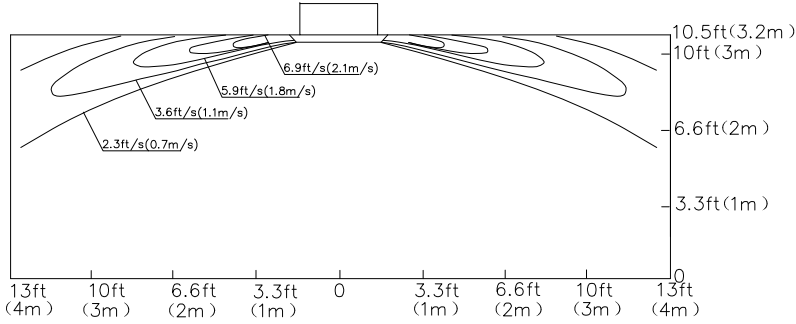

2) Cooling/Air Temperature Distribution

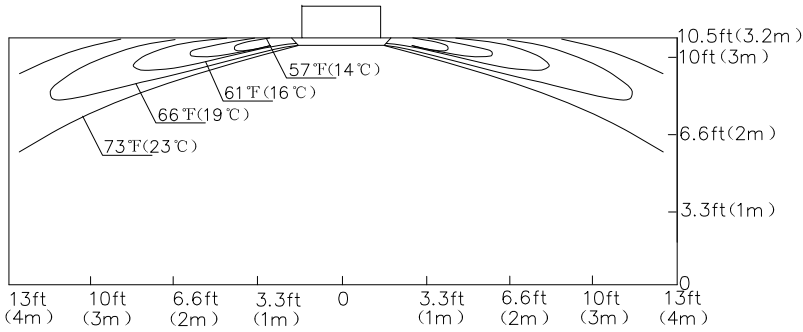

3) Heating/Air Velocity Distribution

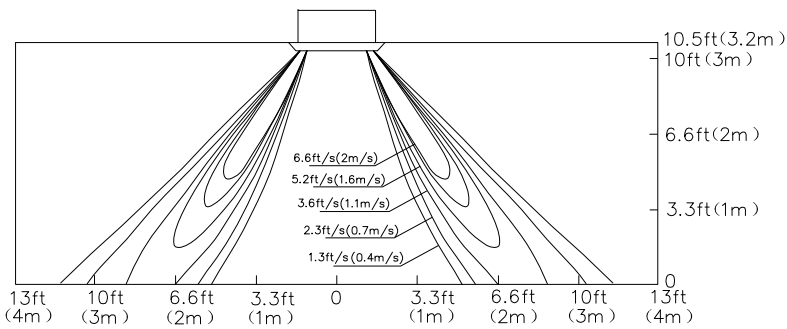

4) Heating/Air Temperature Distribution

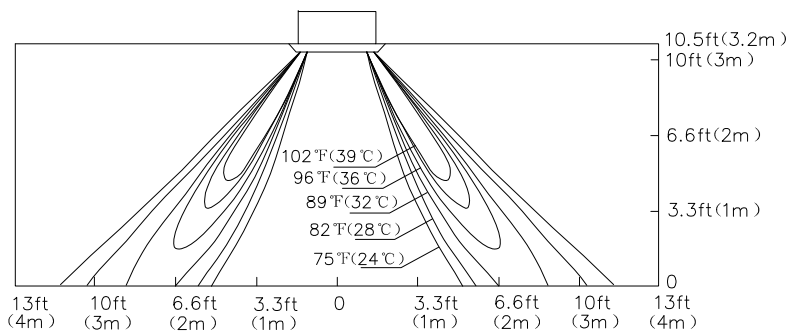

7. AIR FLOW DISTRIBUTION

12K

1) Cooling/Air Velocity Distribution

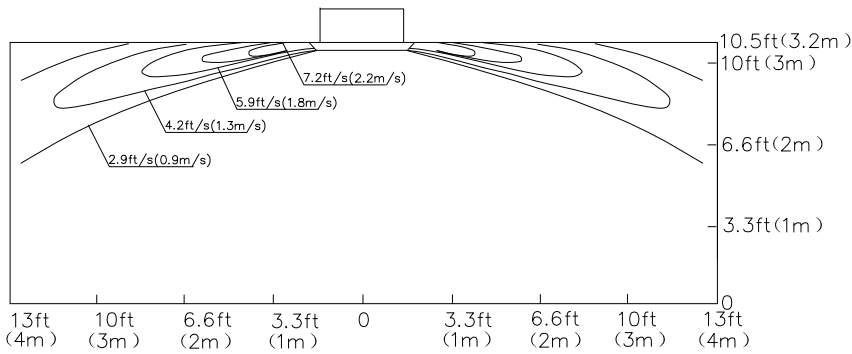

2) Cooling/Air Temperature Distribution

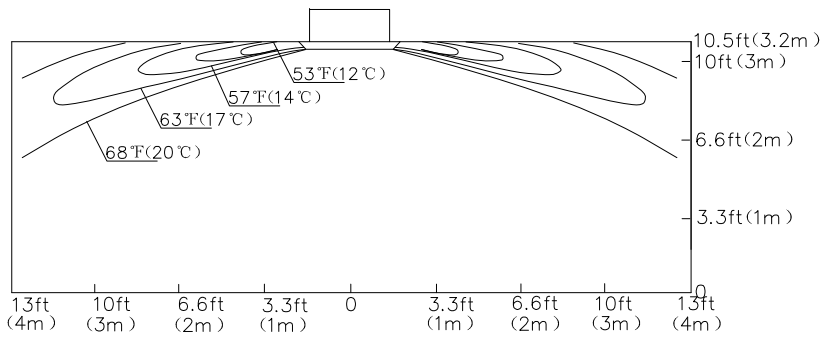

3) Heating/Air Velocity Distribution

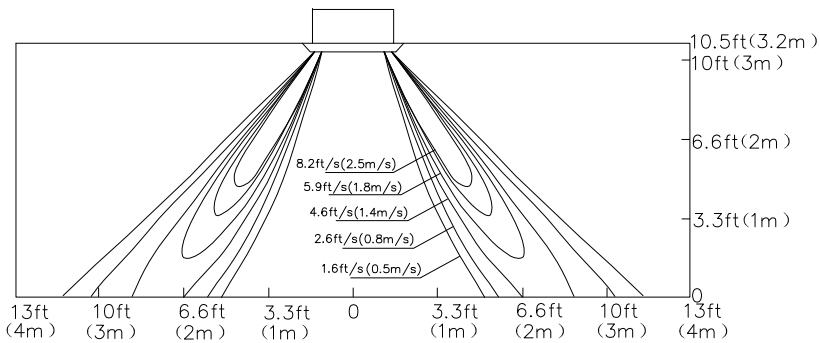

4) Heating/Air Temperature Distribution

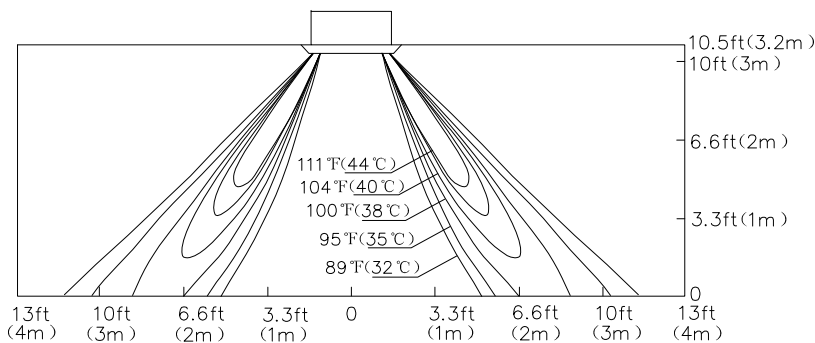

7. AIR FLOW DISTRIBUTION

18K/24K

1) Cooling/Air Velocity Distribution

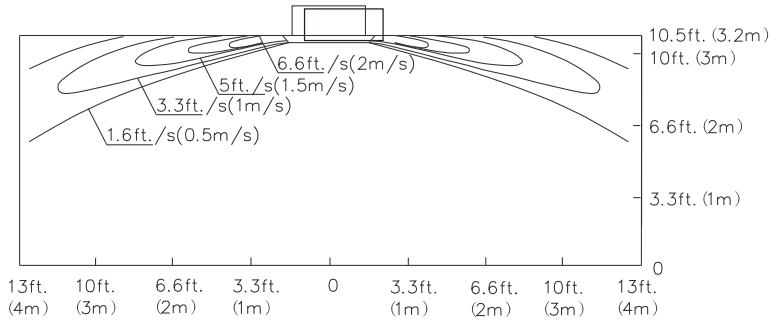

2) Cooling/Air Temperature Distribution

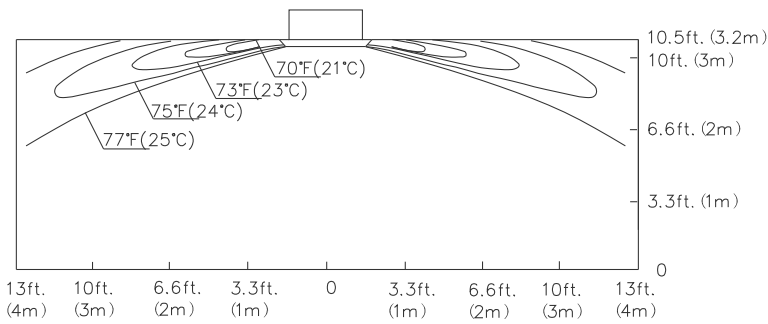

3) Heating/Air Velocity Distribution

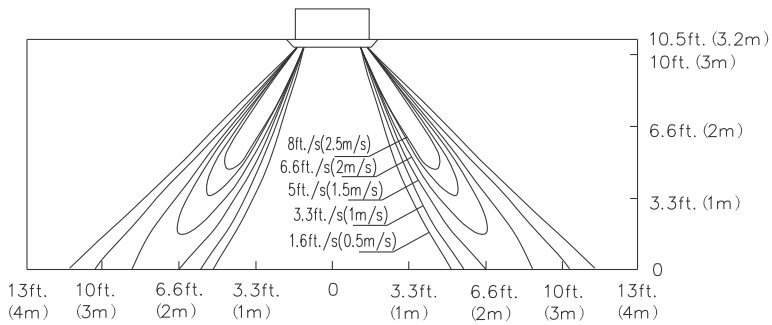

4) Heating/Air Temperature Distribution

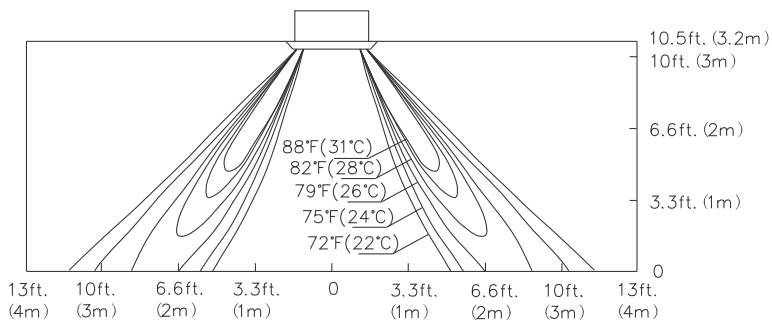

7. AIR FLOW DISTRIBUTION

36K

1) Cooling/Air Velocity Distribution

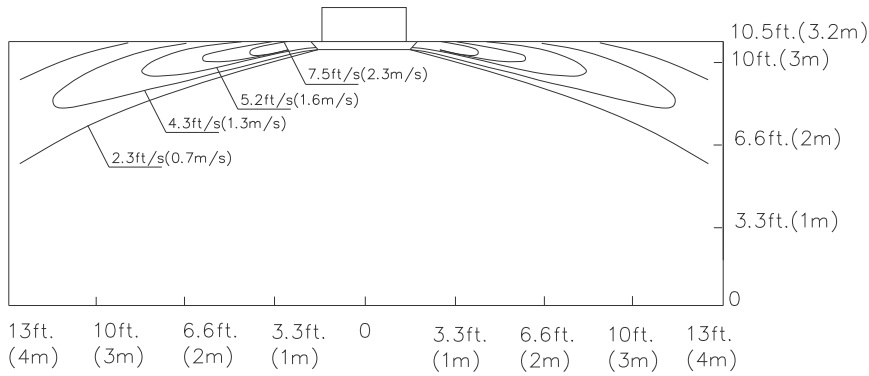

2) Cooling/Air Temperature Distribution

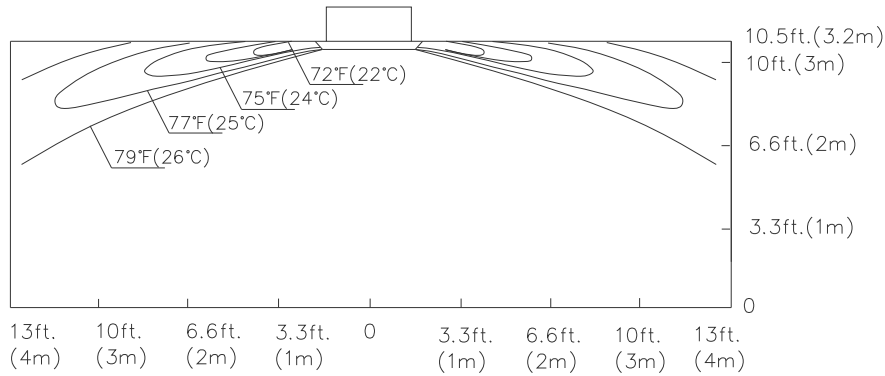

3) Heating/Air Velocity Distribution

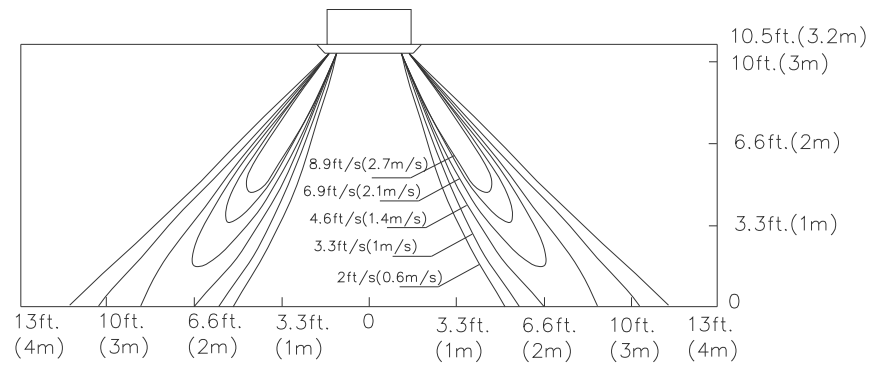

4) Heating/Air Temperature Distribution

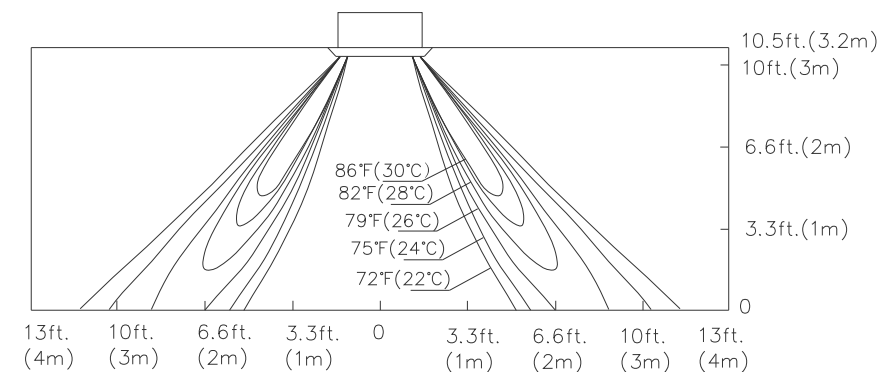

8. ESP (EXTERNAL STATIC PRESSURE) CHART (DUCTED TYPE)

8. ESP (External static pressure) chart (Duct type)

9K

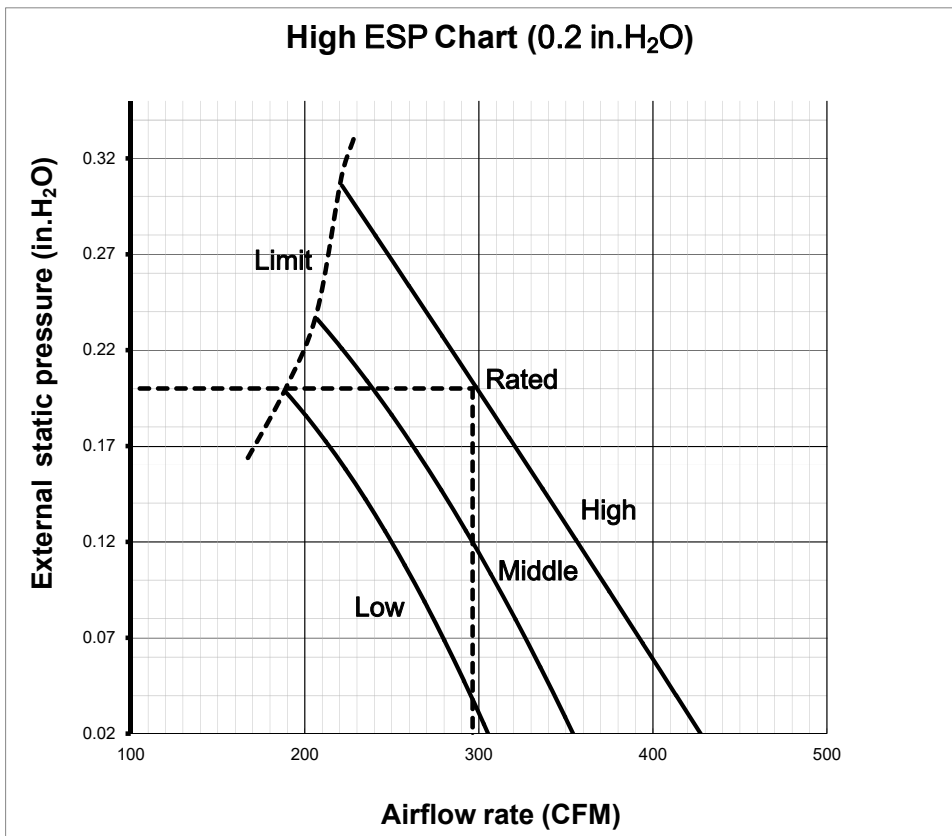
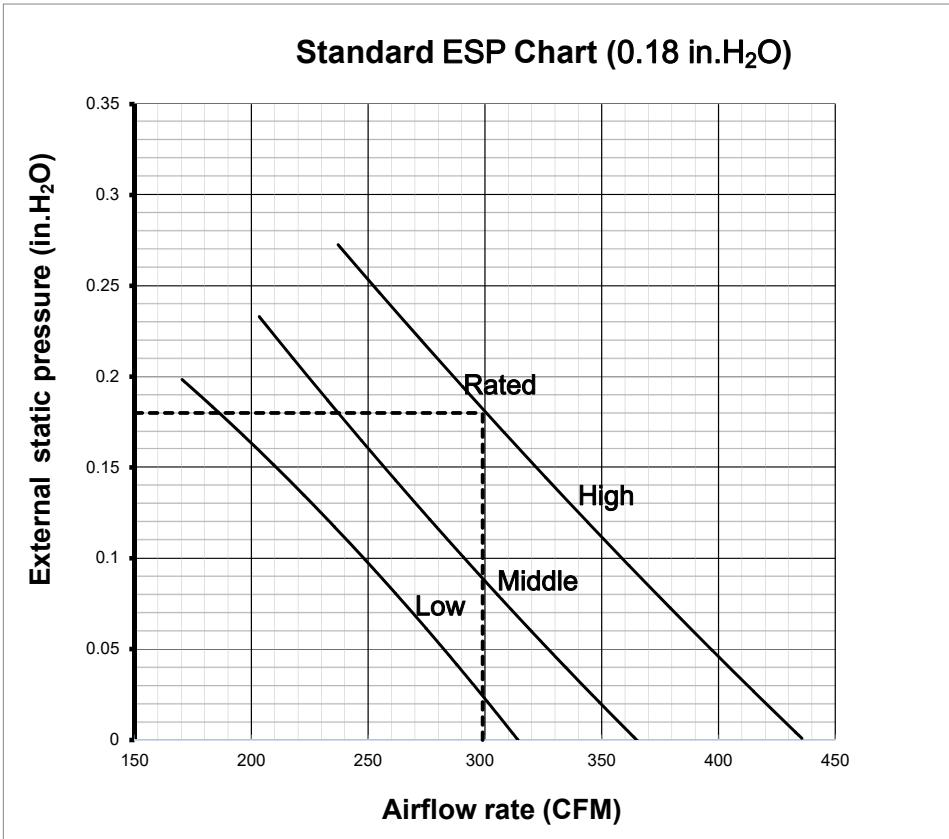

8. ESP (EXTERNAL STATIC PRESSURE) CHART (DUCT TYPE)

12K

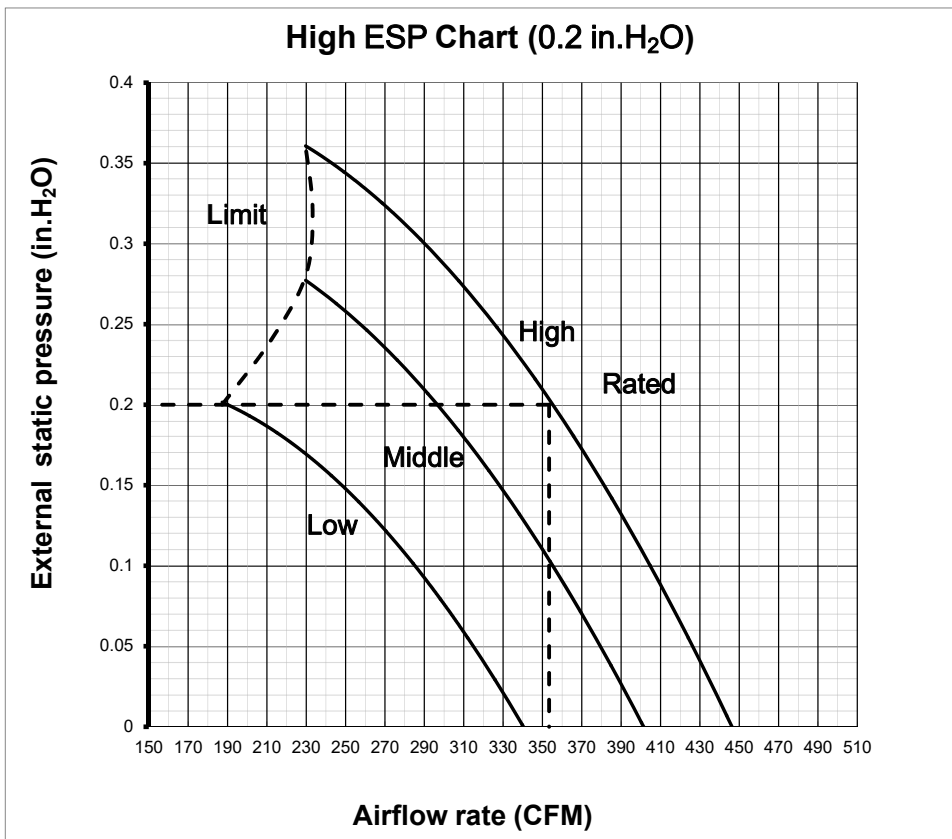
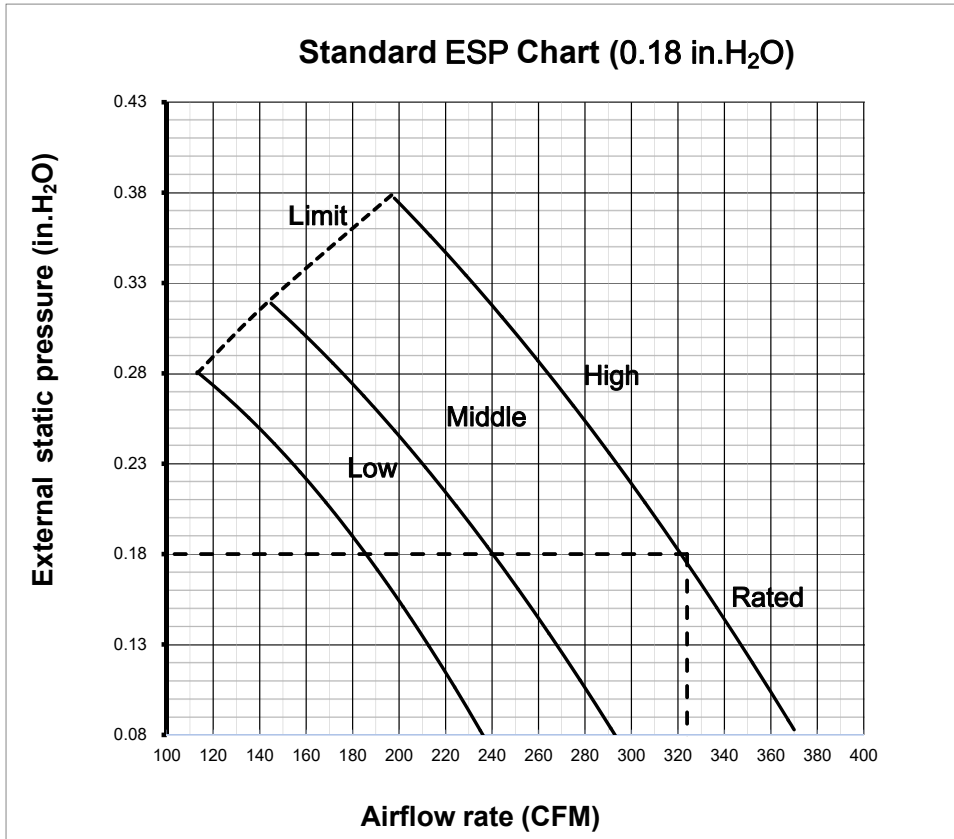

8. ESP (EXTERNAL STATIC PRESSURE) CHART (DUCT TYPE)

18K

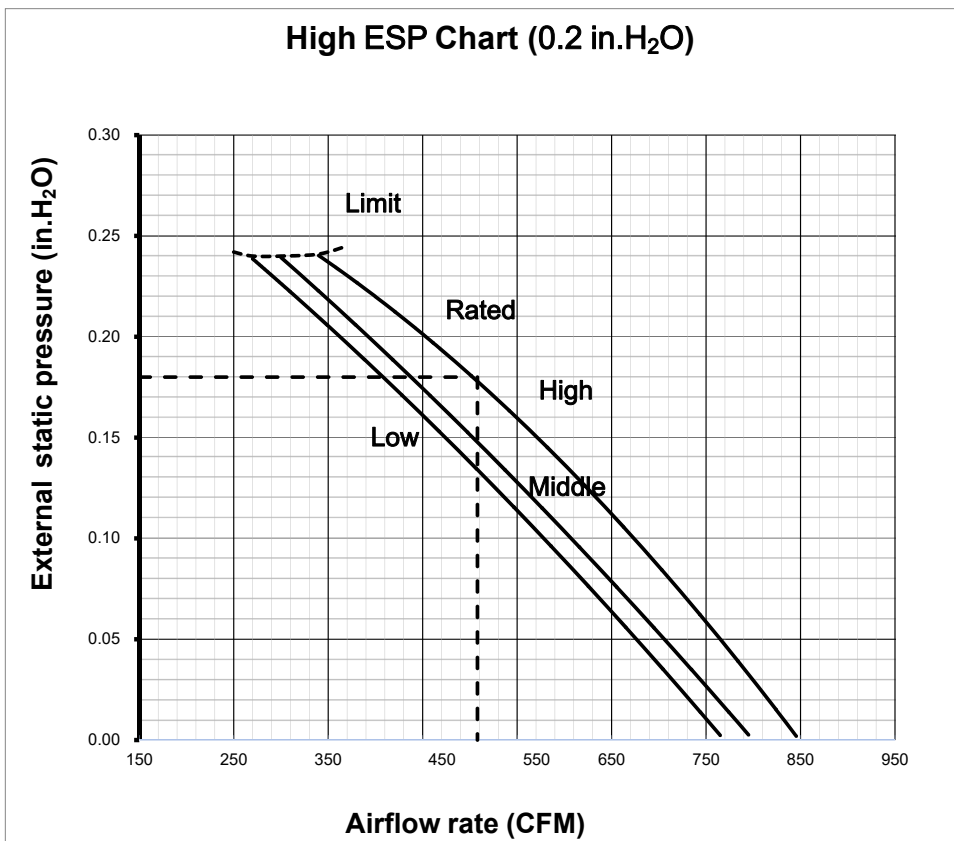
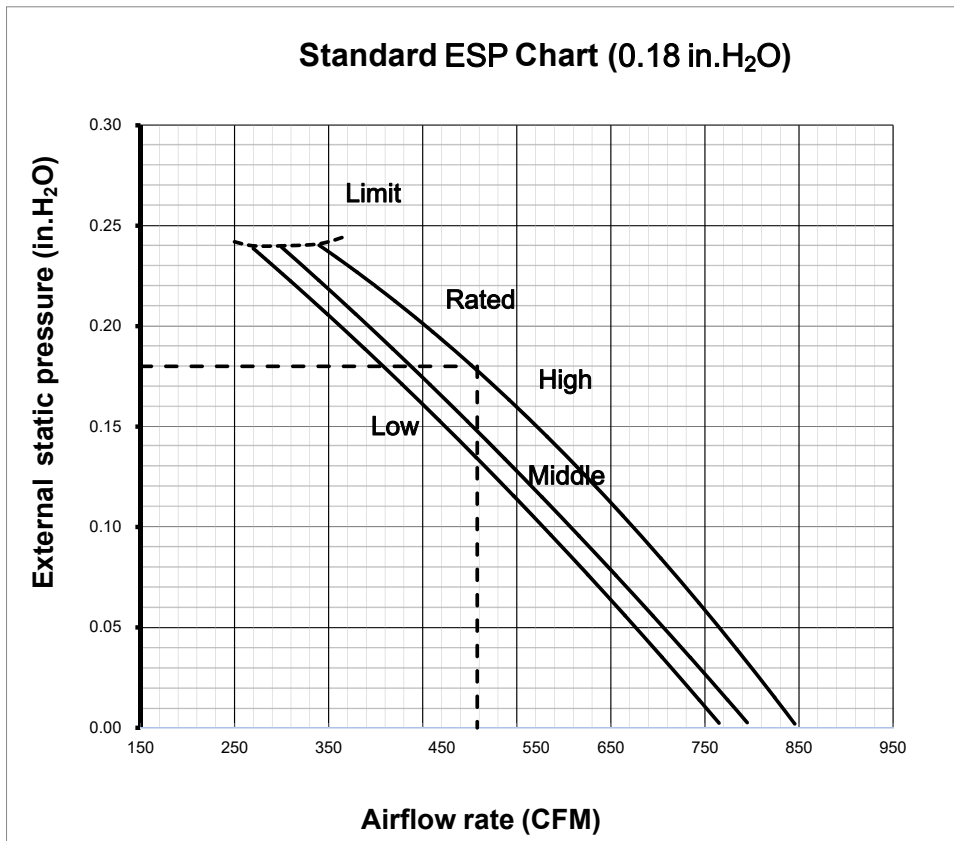

8.ESP (EXTERNAL STATIC PRESSURE) CHART (DUCT TYPE)

24K

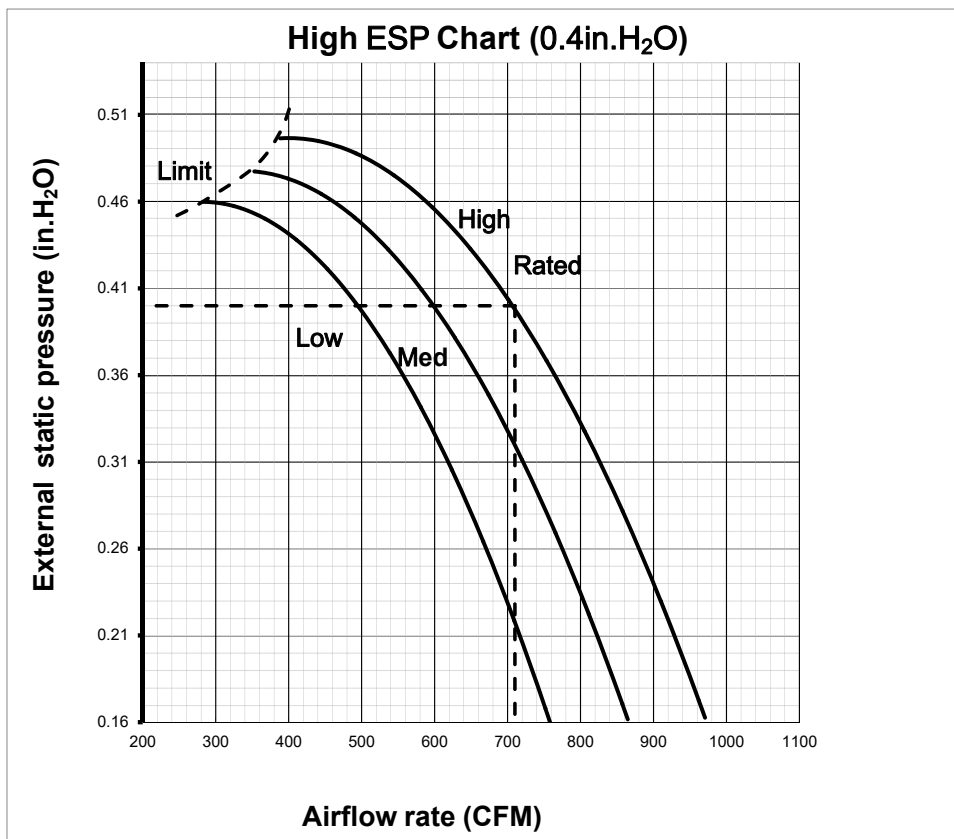
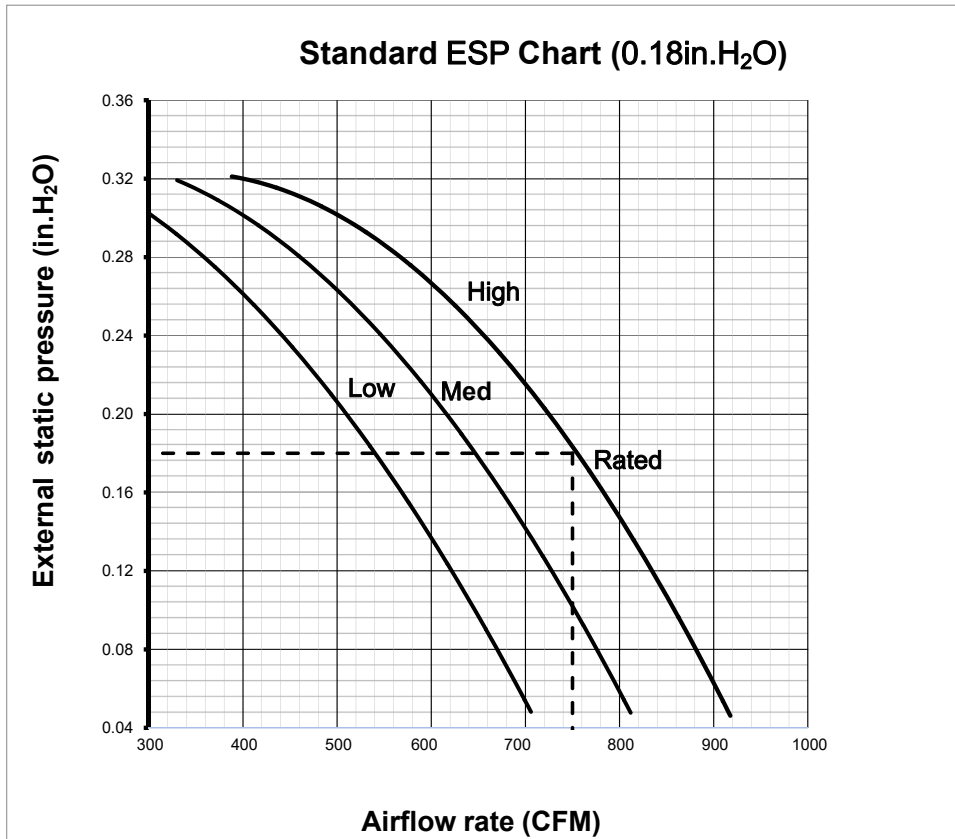

8. ESP (EXTERNAL STATIC PRESSURE) CHART (DUCT TYPE)

36K

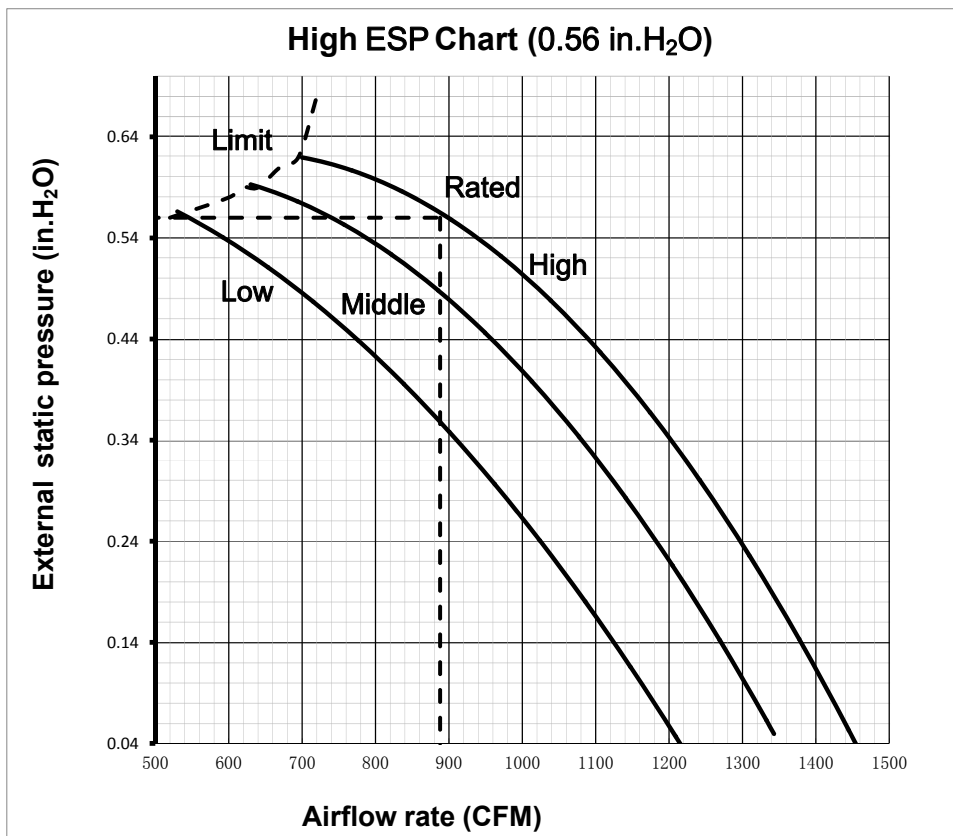
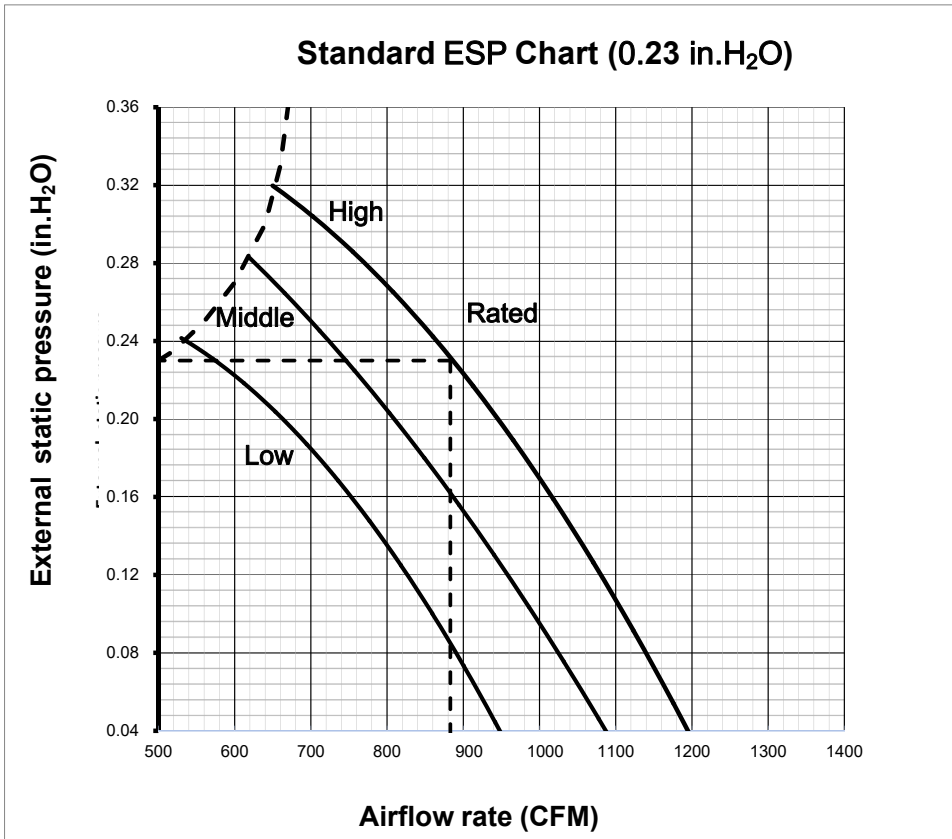

9. REFRIGERANT CYCLE

9. Refrigerant cycle

Indoor unit

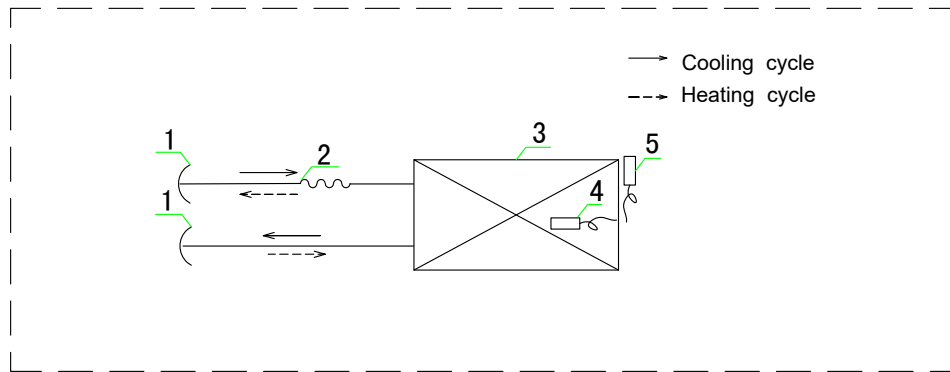

List of components	
1	Hexagon nut
2	Split capillary
3	Indoor heat exchanger
4	Ambient temperature sensor
5	Coil temperature sensor

9. REFRIGERANT CYCLE

Outdoor unit

9K/12K/18K

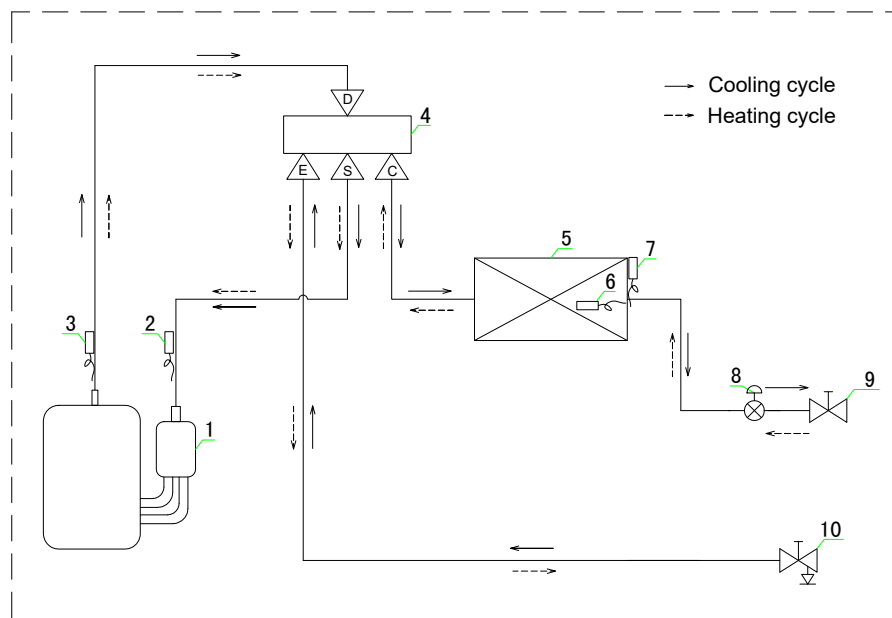

List of components

1	Compressor
2	Suction temperature sensor
3	Discharge temperature sensor
4	4-way valve
5	Outdoor heat exchanger
6	Ambient temperature sensor
7	Coil temperature sensor
8	Electronic expansion valve
9	Stop valve (Liquid)
10	Stop valve (Gas)

9. REFRIGERANT CYCLE

24K

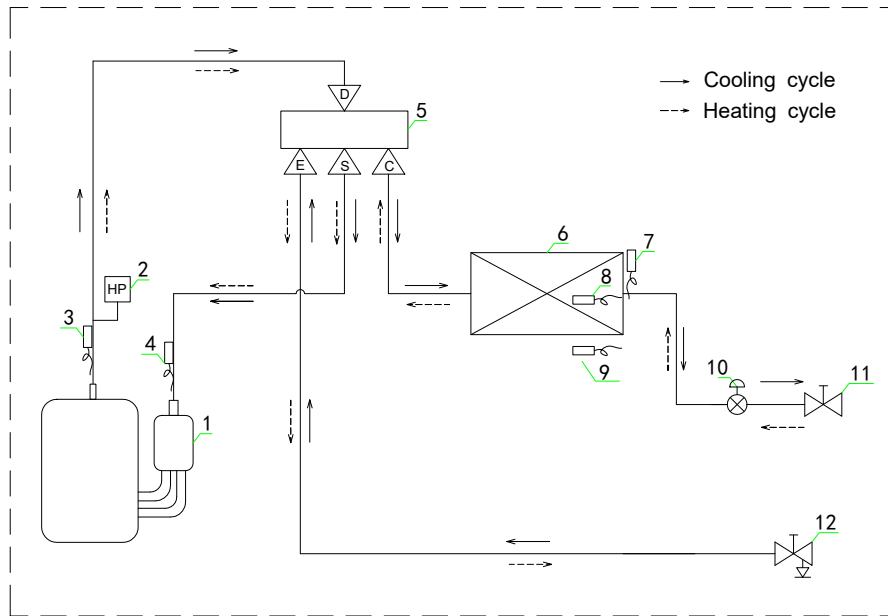

List of components

1	Compressor	7	Coil temperature sensor
2	High pressure switch	8	Defrost temperature sensor
3	Discharge temperature sensor	9	Ambient temperature sensor
4	Suction temperature sensor	10	Electronic expansion valve
5	4-Way valve	11	Stop valve (Liquid)
6	Outdoor heat exchanger	12	Stop valve (Gas)

9. REFRIGERANT CYCLE

36K

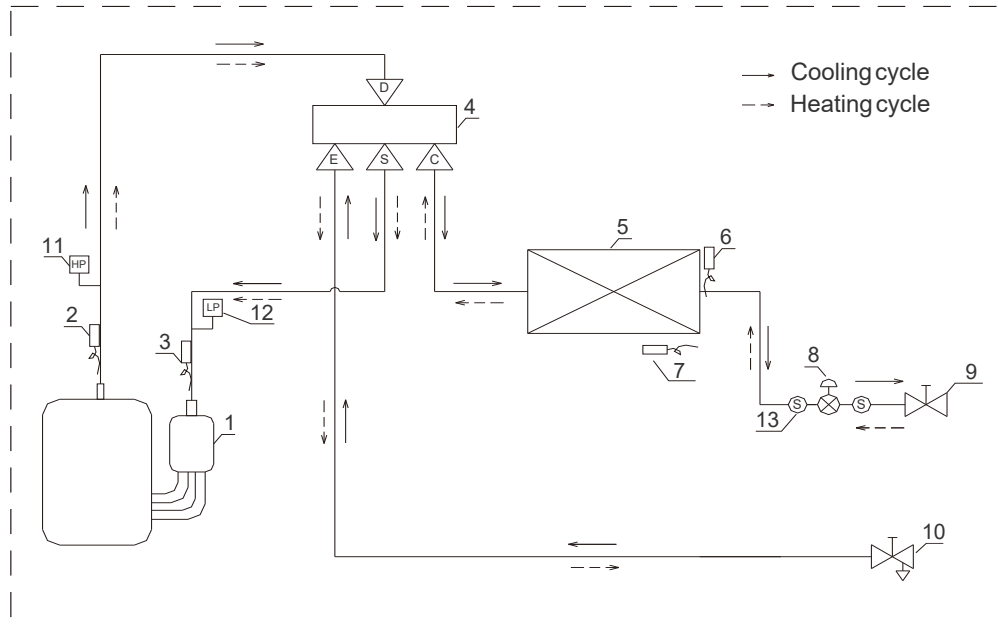

List of component names

1	Compressor	8	Electronic expansion valve
2	Discharge temperature sensor	9	Stop valve
3	Suction temperature sensor	10	Stop valve
4	4-Way valve	11	High pressure switch
5	Outdoor heat exchange	12	Low pressure switch
6	Coil temperature sensor	13	Strainer
7	Ambient temperature sensor		

10. FRESH AIR INTAKE FUNCTION

10. Fresh air intake function

Duct (9K~18K)

Indoor unit can take fresh air from the reserved fresh air intake, the size of the fresh air intake hole is $\Phi 2\text{-}1/2$ in. ($\Phi 65\text{mm}$) (9K~18K)..

Please follow the steps below when needed.

- 1) Cut off the reserved metal circular hole on the base board.
- 2) Connect air duct with the fresh air intake.

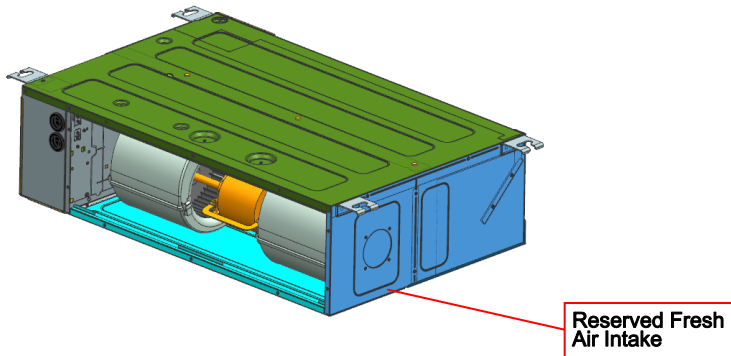

Cassette

Indoor unit can take fresh air from the reserved fresh air intake, the size of the fresh air intake hole is $3\text{-}1/4$ in. \times $1\text{-}11/16$ in. ($83\text{mm}\times 43\text{mm}$) (9K/12K), 3 in. \times $2\text{-}1/16$ in. ($75\text{mm}\times 53\text{mm}$) (18K/24K/36K). Please follow the steps below when needed.

- 1) Cut off the reserved metal rectangular hole on the base board.
- 2) Cut off the foam material on the a rectangular hole.
- 3) Connect air duct with the fresh air intake.

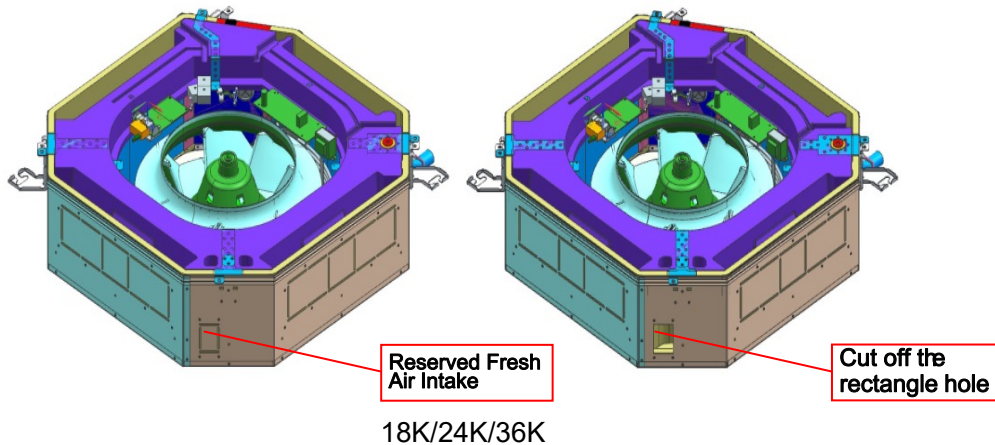
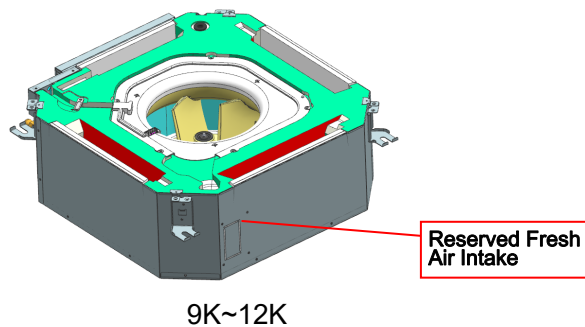

11. WIRING DIAGRAM

11. Wiring diagram

11.1 Electrical wiring diagram

Indoor unit

Duct type

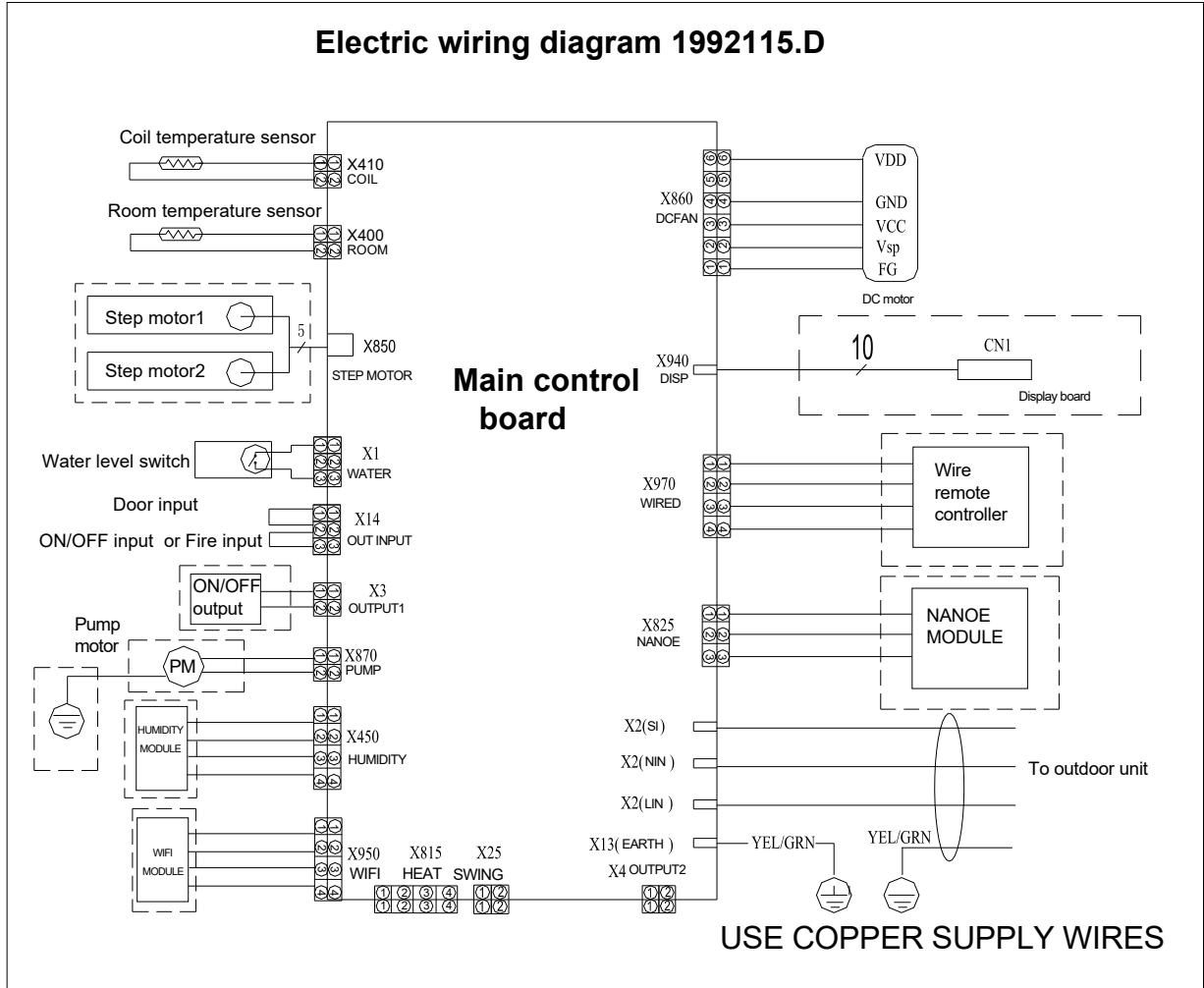

Remark:

Dashed parts are not available in some models.

For details see the table below.

	Indoor units model	Step motor	Pump motor	Humidity	WIFI Module	NANOE Module	Display board	Wired remote controller	ON/OFF output
Duct	9K~18K							●	●

●--available part

11. WIRING DIAGRAM

Duct type

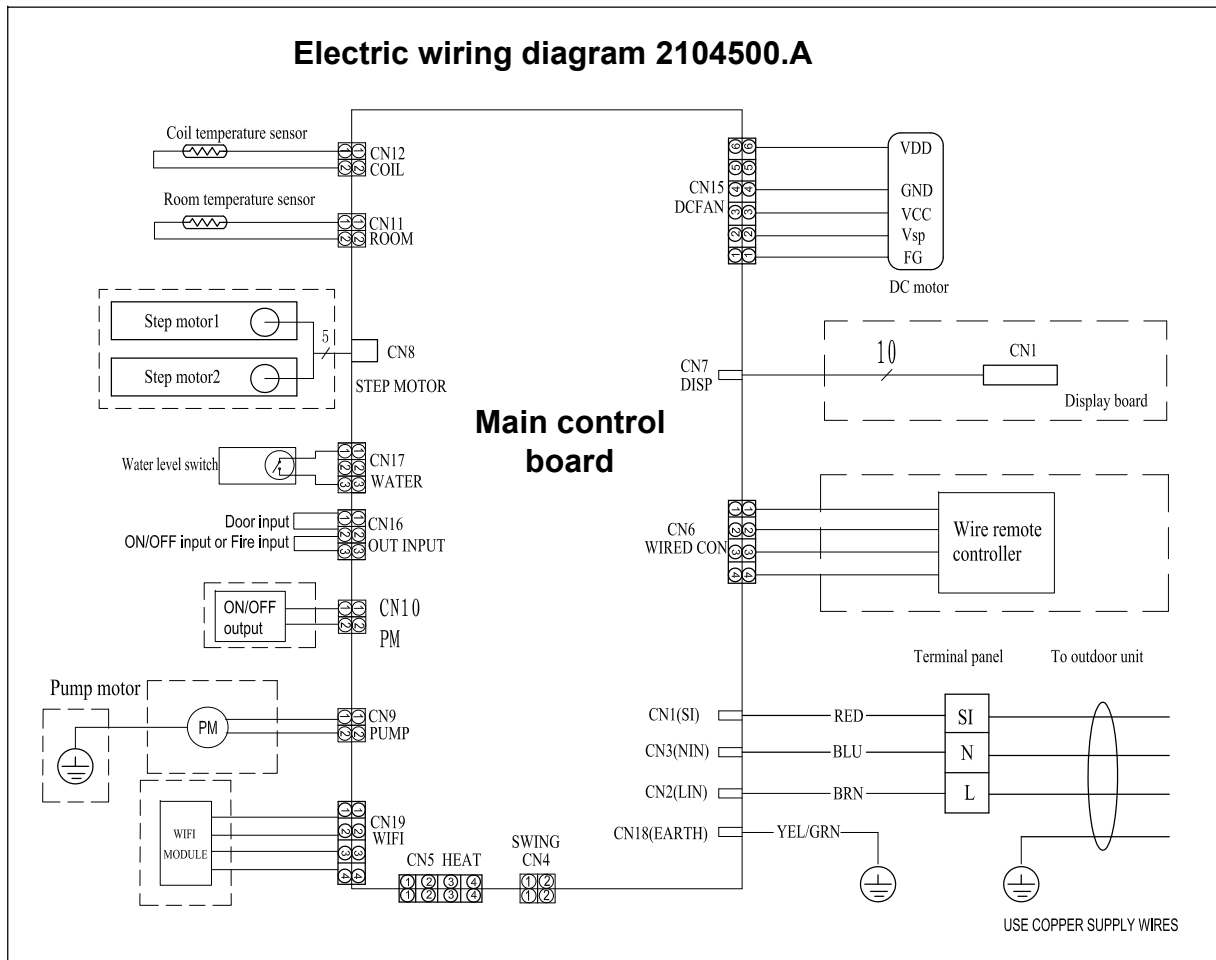

Remark:

Dashed parts are not available in some models.
For details see the table below.

	Indoor units model	Step motor	Pump motor	WiFi module	Display board	Wire remote controller	ON/OFF output
Duct	24K/36K					●	●

●--available part

11. WIRING DIAGRAM

Cassette type

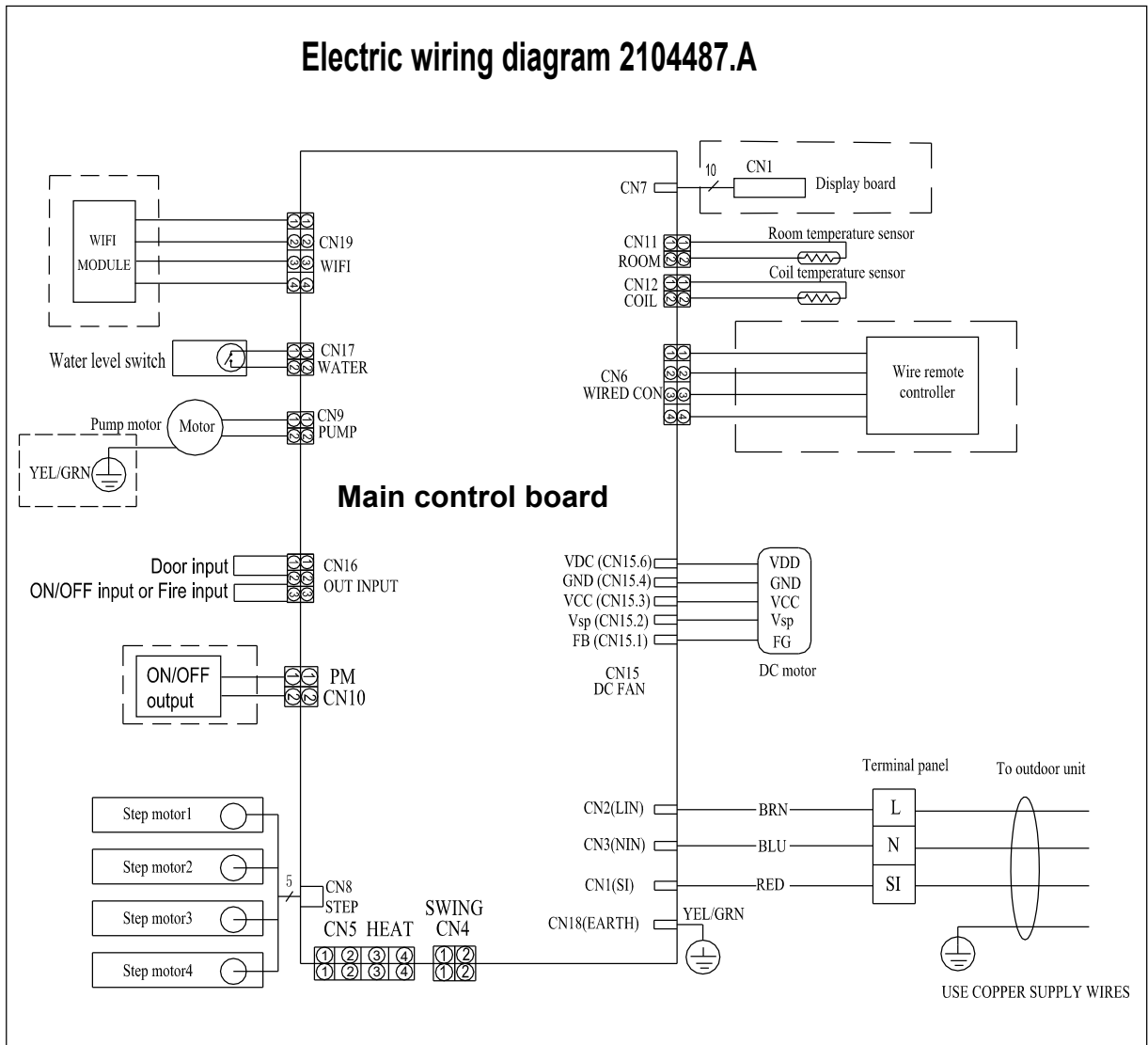

Remark:

Dashed parts are not available in some models.
For details see the table below.

Cassette	Indoor units model	Step motor	Pump motor	WIFI module	Display board	Wire remote controller	ON/OFF output
	9K~36K	●	●		●		●

●--available part

11. WIRING DIAGRAM

Outdoor unit
9K/12K/18K

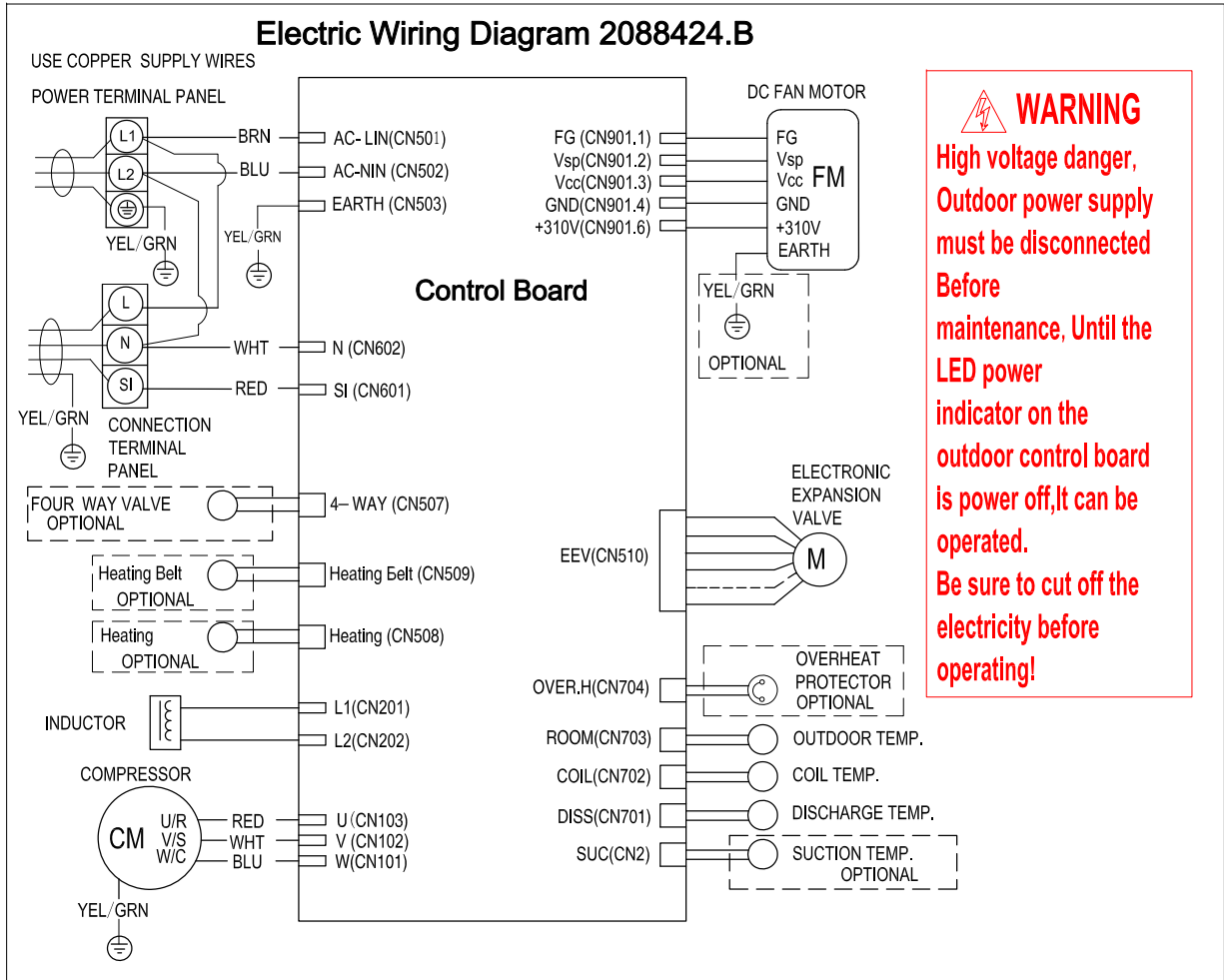

Remark:

Dashed parts are not available in some models.
For details see the table below.

Outdoor units model	Heating belt	Overheat protector	4-way valve	YEL/GRN	Heating	Suction temp.
9K/12K/18K	●	●	●		●	

●--available part

11. WIRING DIAGRAM

24K

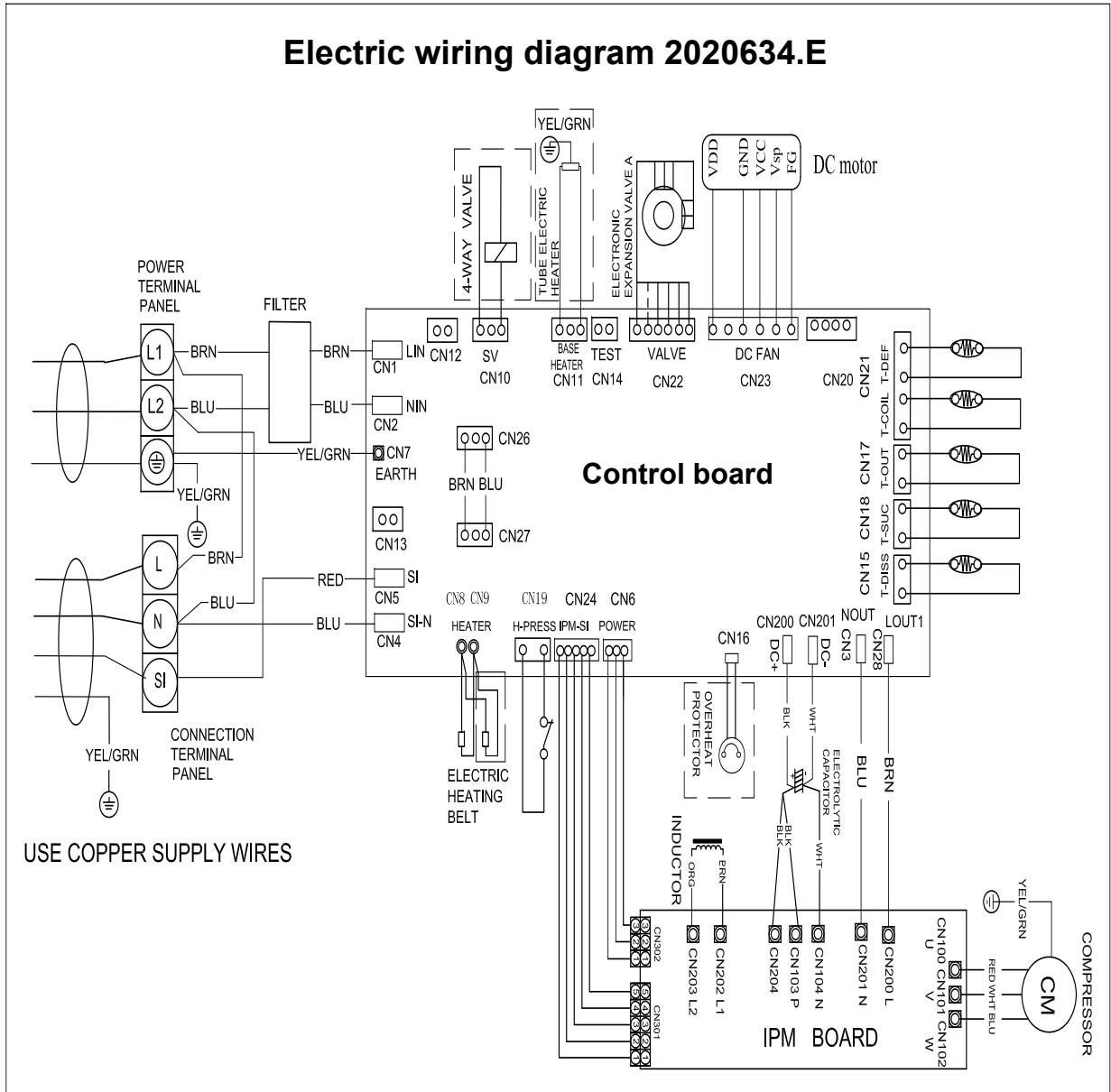

Remark:

Dashed parts are not available in some models.

For details see the table below.

Outdoor unit model	4-way valve	Tube electric heater	Electric heating belt	Overheat protector
24K	●	●	●	●

●--available part

11. WIRING DIAGRAM

36K

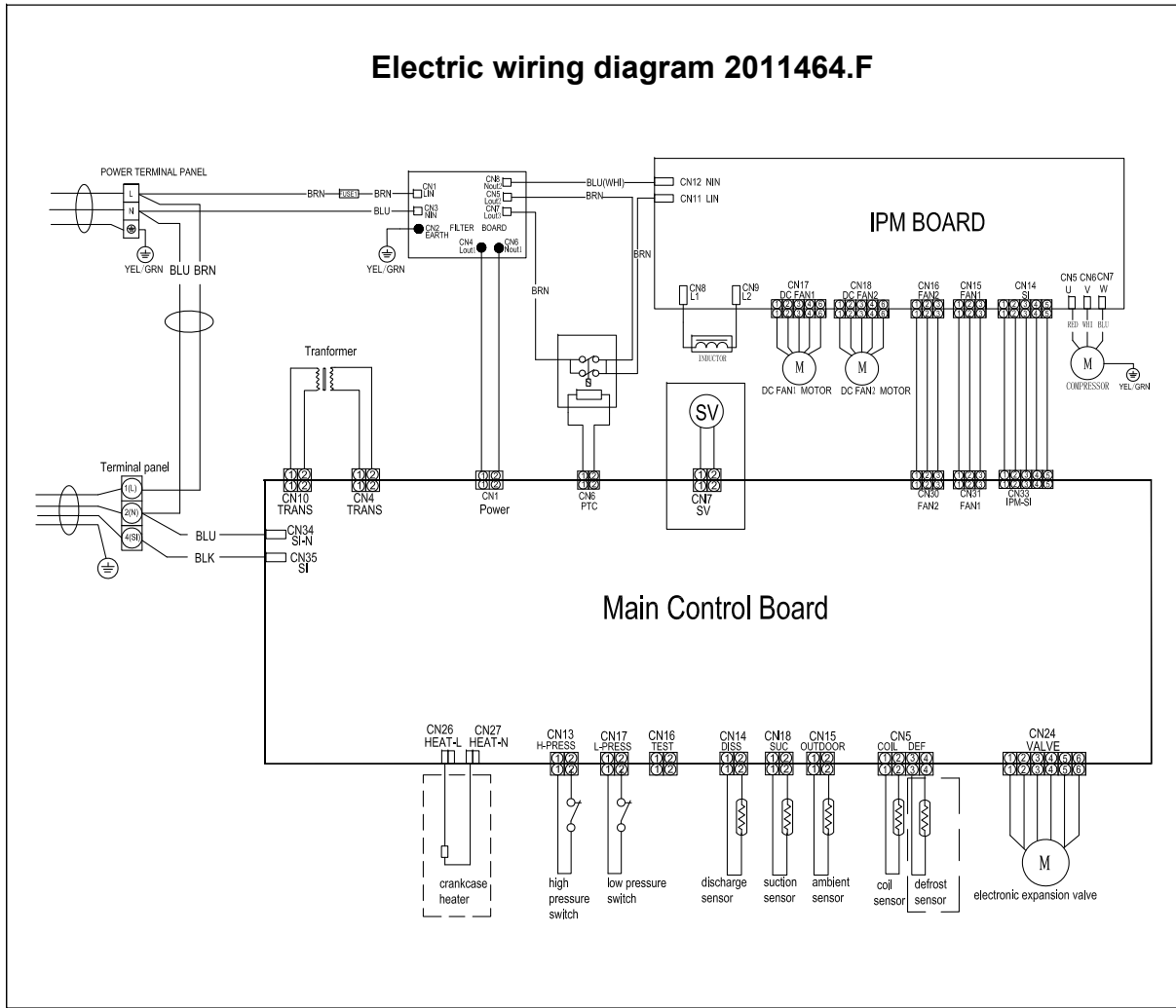

Remark:

Dashed parts are not available in some models.
For details see the table below.

Outdoor unit model	Crankcase heater	Defrost sensor
36K	●	●

●--available part

11. WIRING DIAGRAM

11.2 Control board picture

Indoor unit

Duct (9K/12K/18K)

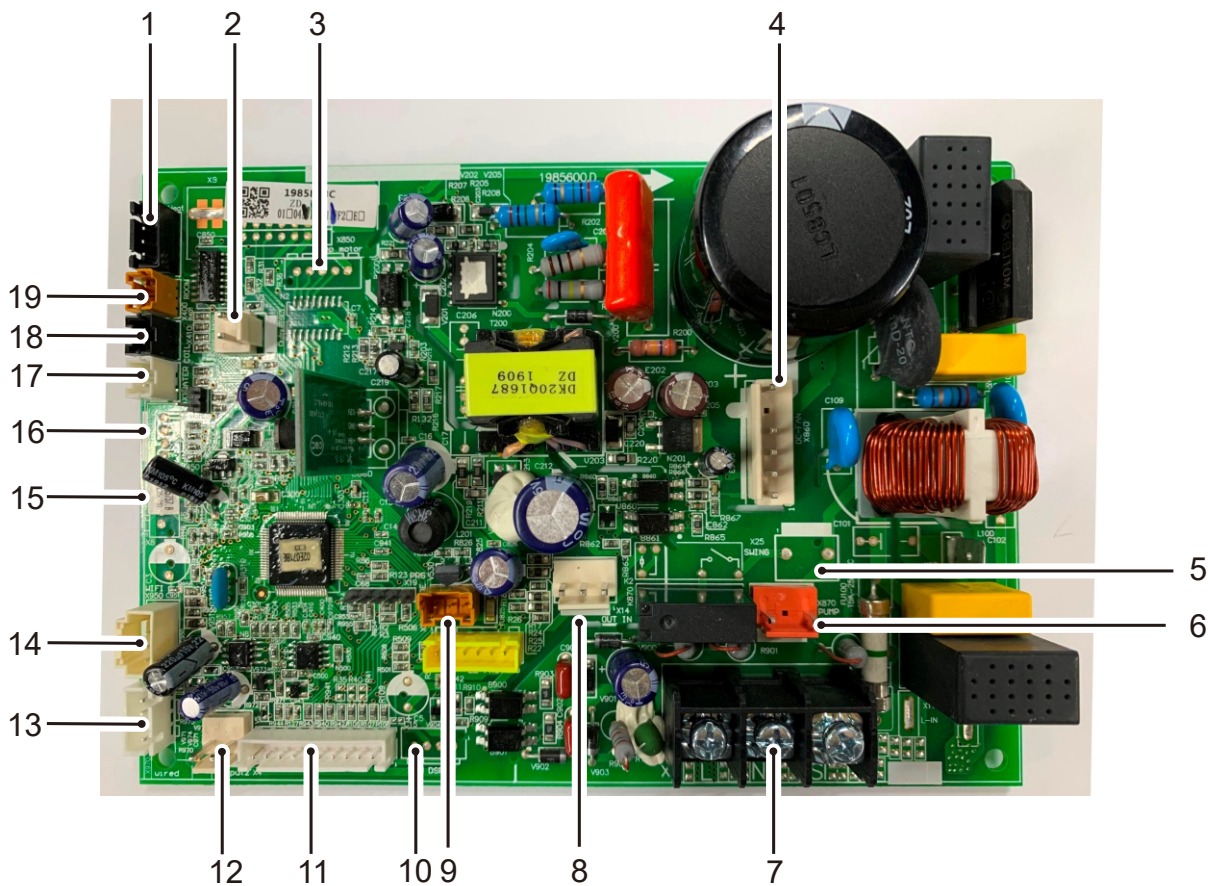

NO.	Description	NO.	Description
1	Heat	11	Disp
2	Output1	12	Output2
3	Step Motor	13	Wired.
4	DC Fan	14	Wi-Fi
5	Swing	15	Reserved
6	Pump	16	Humidity
7	L, N Power Input	17	Water Level Switch
8	Out	18	Coil Temp. Sensor
9	Nano	19	Ambient Temp. Sensor
10	Disp		

11. WIRING DIAGRAM

Indoor unit

Duct (24K/36K) & Cassette (9K~36K)

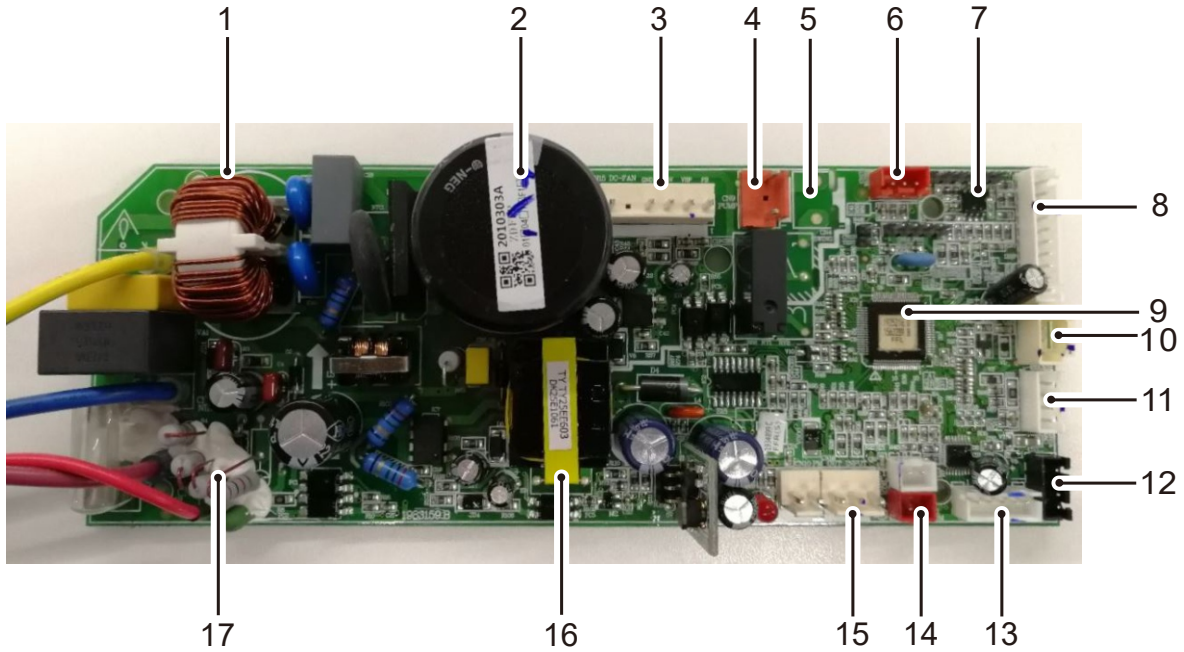

NO.	Description	NO.	Description
1	AC Power Filter	10	Wi-Fi
2	Main Control Component Code	11	Wired Controller
3	DC Motor	12	Electric Heater
4	Pump Motor	13	Step Motor
5	Swing Motor	14	Temp. Sensor
6	Water Level Switch	15	Out Input
7	EE	16	Switching Power Supply
8	Display	17	Communication with outdoor unit
9	MCU		

11. WIRING DIAGRAM

Outdoor unit

9K/12K

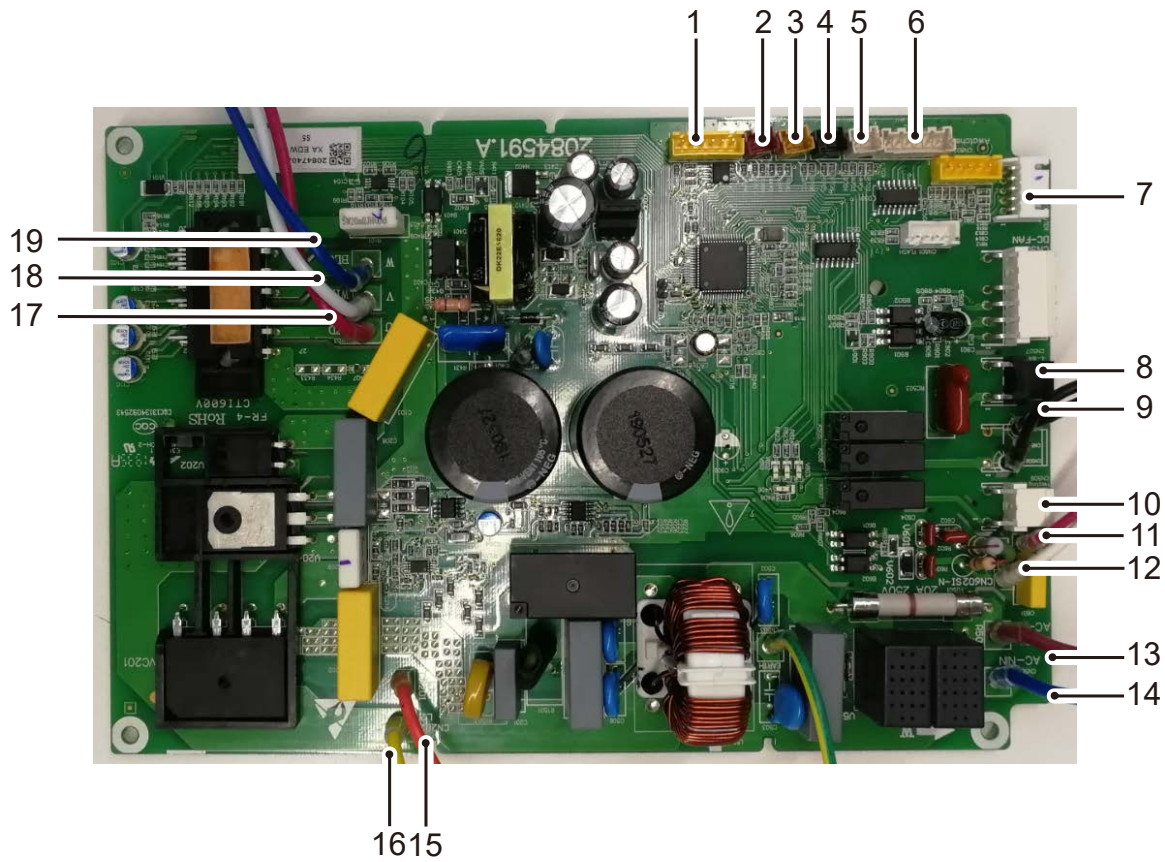

NO.	Description	NO.	Description
1	EE	11	SI
2	Overheat Switch	12	SI-N
3	Ambient Temperature Sensor	13	AC IN-L
4	Coil Temperature Sensor	14	AC IN-N
5	Discharge Temperature Sensor	15	Reactor L1
6	Electric expansion Valve	16	Reactor L2
7	Checker/Computer	17	Compressor U
8	4-Way Valve	18	Compressor V
9	Heater (L/N)	19	Compressor W
10	Heating Belt		

11. WIRING DIAGRAM

Outdoor unit

18K

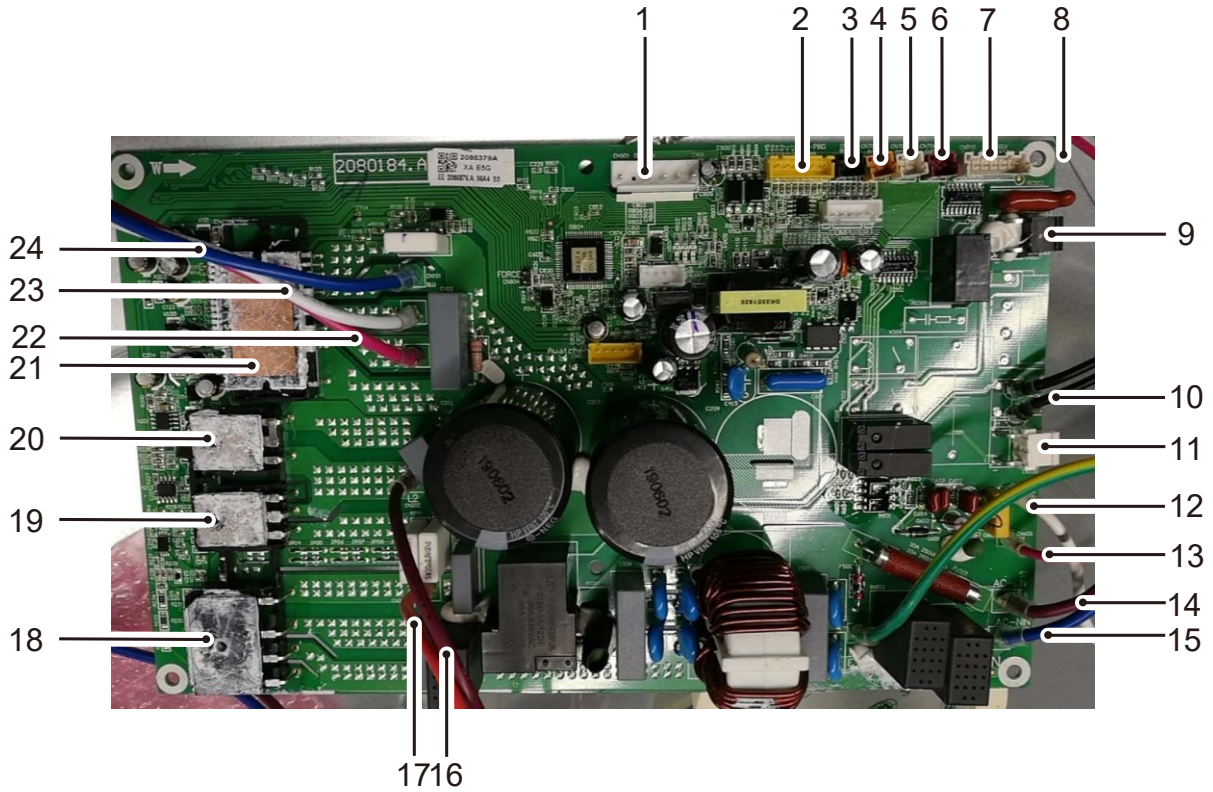

NO.	Description	NO.	Description
1	DC FAN	13	SI-L
2	EE	14	AC IN-L
3	Coil Temperature Sensor	15	AC IN-N
4	Ambient Temperature Sensor	16	Reactor L1
5	Discharge Temperature Sensor	17	Reactor L2
6	Overheat Protector	18	Rectifier Bridge
7	Electric expansion Valve	19	Diode
8	Electric Expansion Valve	20	IGBT
9	4-Way Valve	21	IPM
10	Heater (L/N)	22	Compressor U
11	Heating Belt	23	Compressor V
12	SI-N	24	Compressor W

11. WIRING DIAGRAM

Outdoor unit

24K

Main control board

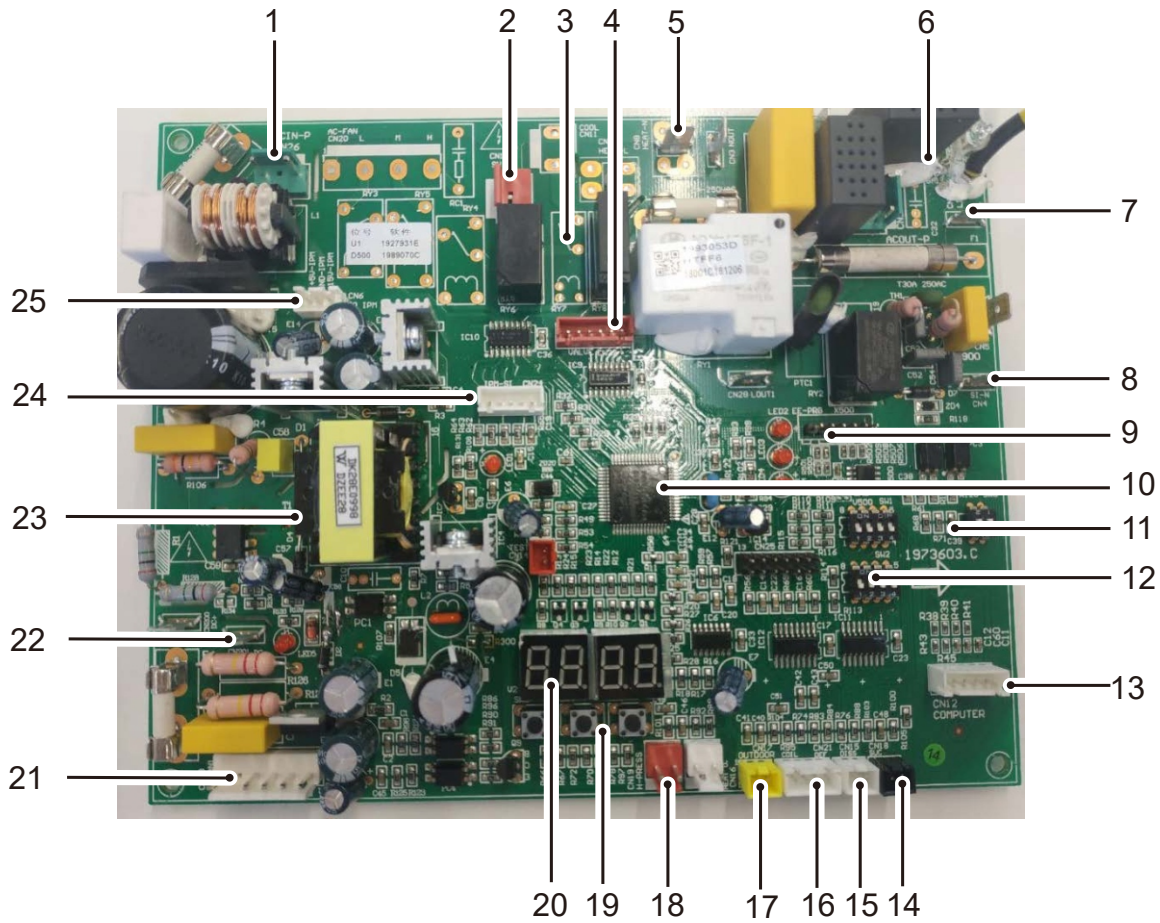

NO.	Description	NO.	Description
1	ACIN-P	14	Suction temperature Sensor
2	4-Way Valve	15	Discharge temperature Sensor
3	Tube electric heater	16	Coil & Defrost temperature Sensor
4	Electric Expansion Valve	17	Ambient temperature Sensor
5	Electric Heating Belt	18	High Pressure Switch
6	ACIN-P	19	Button
7	AC Power Input	20	7-Segment Display
8	Communication with Indoor Unit	21	DC motor
9	EE	22	DC-310V Supply
10	MCU Component	23	Switching Power Supply
11	Protector for Electric Heater Belt First Power ON	24	Drive Board Communication
12	DIP Switch	25	Drive Board Power Supply
13	Monitor/Checker/Computer		

11. WIRING DIAGRAM

Outdoor unit

36K

Main control board

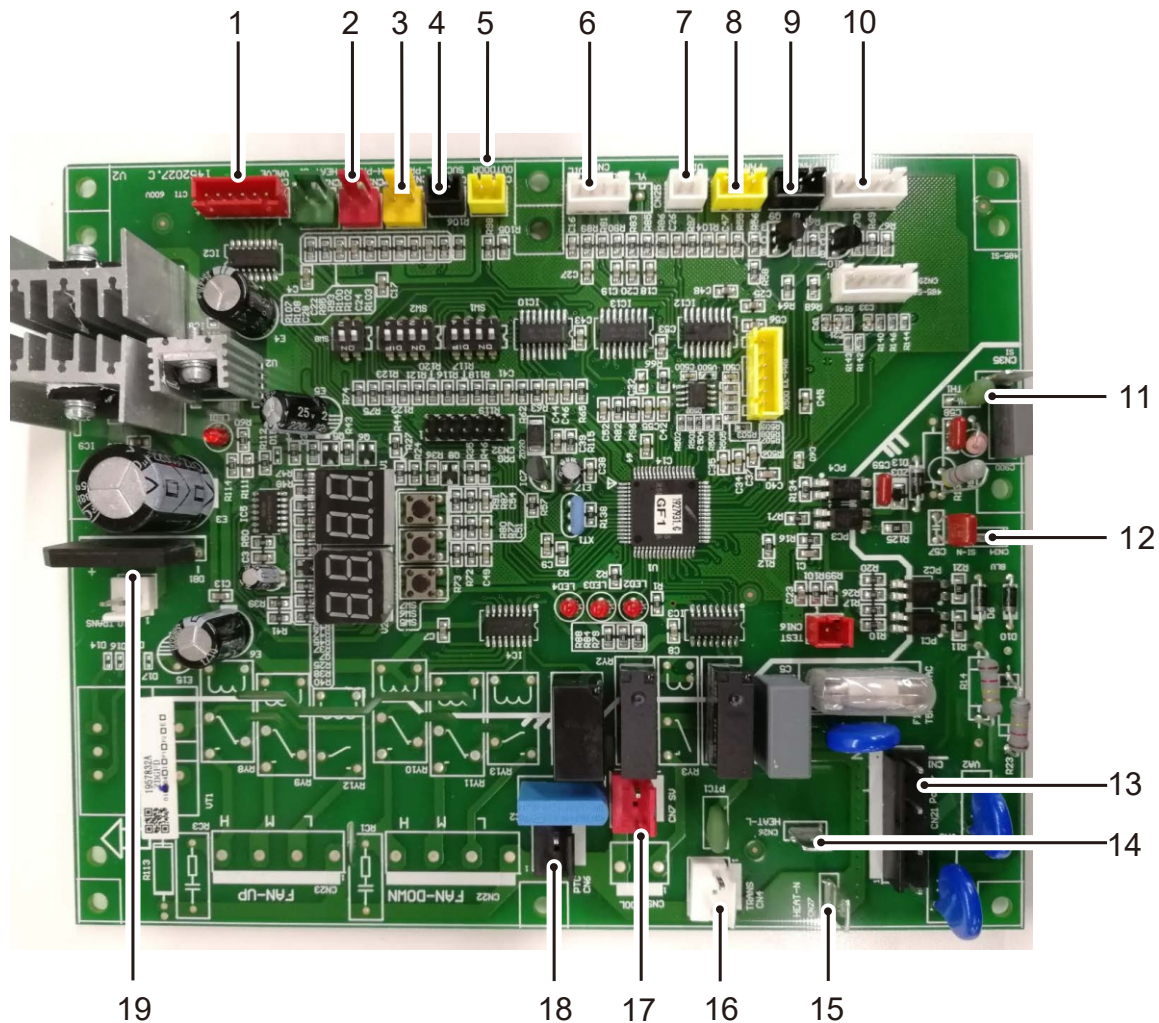

NO.	Description	NO.	Description
1	Electric Expansion Valve	11	Communication SI
2	High Pressure Switch	12	Communication SI-N
3	Low Pressure Switch	13	Power
4	Suction Temperature Sensor	14	Heater-L
5	Ambient Temperature Sensor	15	Heater-N
6	Coil/Defrost Temperature Sensor	16	Transformer Output Side
7	Discharge Temperature Sensor	17	4-Way Valve
8	DC Fan 2-SI	18	PTC
9	DC Fan 1-SI	19	Transformer Output Side
10	IPM-SI		

11. WIRING DIAGRAM

Outdoor unit

24K

Drive board

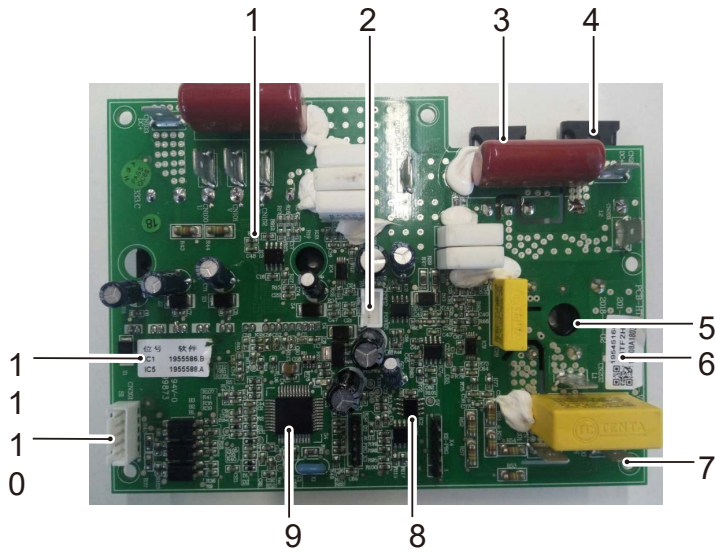

NO.	Description	NO.	Description
1	IPM Module	7	AC Power Input
2	12V&5V Power	8	EE
3	IGBT	9	MCU Component
4	Diodes	10	Communication with Upper System
5	Rectifier Bridge	11	CPU code
6	Drive Board Code		

36K

Drive board

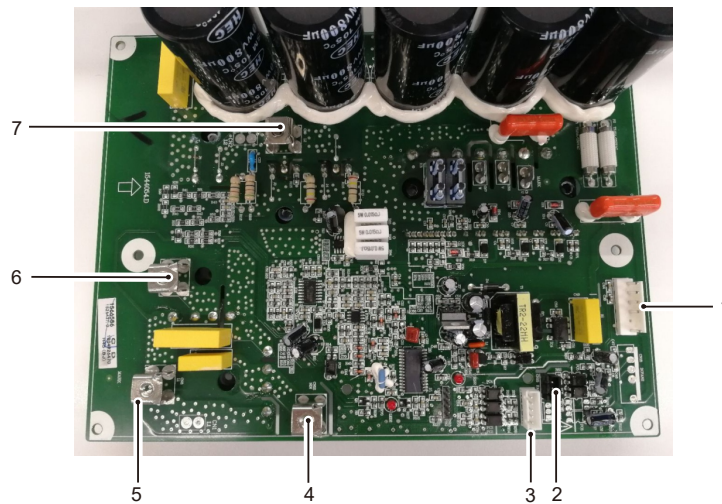

NO.	Description	NO.	Description
1	DC FAN motor	5	AC Power LIN
2	DC-FAN-SI	6	Reactor -L1
3	IPM-SI	7	Reactor L2
4	AC Power NIN		

11. WIRING DIAGRAM

11.3 Common wiring

Recommended Wire Size

Model (Capacity)	Power Supply	ELB		Power Source Cable Size	Transmitting Cable Size
		Rated Current (A)	Nominal Sensitive Current (mA)		
9K/12K	208/230V ~ / 60Hz	20	30	3×16AWG	4×16AWG
18K/24K	208/230V ~ / 60Hz	32	30	3×12AWG	4×16AWG
36K	208/230V ~ / 60Hz	32	30	3×10AWG	4×16AWG

Max. Running Current (A): REFER TO NAMEPLATE

NOTE:

- Use copper power supply wires.
- Follow local codes and regulations when select field wires, and all the above are the minimum wire size.
- When transmitting cable length is longer than 262ft. (80m), a larger wire size should be selected.
- Install main switch and ELB for each system separately. Select the high response type ELB that acts within 0.1second.

12. FIELD SETTING

12. Field setting

12.1 Outdoor unit DIP switch

DIP Switch Setting of Outdoor Unit (24K/36K)

Turn off all power sources before setting. Without turning off, the switches settings are not refreshed and might be invalid. Mark of "■" indicates the position of DIP switches.

Setting is required

SW2-1 Refrigerant Piping Length Setting	SW2-4 Refrigerant Collection						
<div style="border: 1px solid black; padding: 5px; margin-bottom: 10px;">Setting is required</div> <table border="1" style="width: 100%; border-collapse: collapse;"> <thead> <tr> <th colspan="2" style="text-align: center;">Actual Piping Length L(m)</th> </tr> <tr> <th style="width: 50%; text-align: center;">L < 15</th> <th style="width: 50%; text-align: center;">15 ≤ L < Max. length allowed</th> </tr> </thead> <tbody> <tr> <td style="padding: 5px;"> Setting before shipment ON <input type="checkbox"/> <input type="checkbox"/> <input type="checkbox"/> <input type="checkbox"/> OFF <input checked="" type="checkbox"/> <input checked="" type="checkbox"/> <input checked="" type="checkbox"/> <input checked="" type="checkbox"/> <div style="display: flex; justify-content: space-around; width: 100%;">1234</div> </td> <td style="padding: 5px;"> ON <input checked="" type="checkbox"/> <input type="checkbox"/> <input type="checkbox"/> <input type="checkbox"/> OFF <input type="checkbox"/> <input checked="" type="checkbox"/> <input checked="" type="checkbox"/> <input checked="" type="checkbox"/> <div style="display: flex; justify-content: space-around; width: 100%;">1234</div> </td> </tr> </tbody> </table> <p>After setting refrigerant piping length dip switch, cooling/heating performance can be improved.</p>	Actual Piping Length L(m)		L < 15	15 ≤ L < Max. length allowed	Setting before shipment ON <input type="checkbox"/> <input type="checkbox"/> <input type="checkbox"/> <input type="checkbox"/> OFF <input checked="" type="checkbox"/> <input checked="" type="checkbox"/> <input checked="" type="checkbox"/> <input checked="" type="checkbox"/> <div style="display: flex; justify-content: space-around; width: 100%;">1234</div>	ON <input checked="" type="checkbox"/> <input type="checkbox"/> <input type="checkbox"/> <input type="checkbox"/> OFF <input type="checkbox"/> <input checked="" type="checkbox"/> <input checked="" type="checkbox"/> <input checked="" type="checkbox"/> <div style="display: flex; justify-content: space-around; width: 100%;">1234</div>	<div style="display: flex; align-items: center; justify-content: center;"> <div style="margin-right: 10px;"> ON <input type="checkbox"/> <input type="checkbox"/> <input type="checkbox"/> <input type="checkbox"/> OFF <input checked="" type="checkbox"/> <input checked="" type="checkbox"/> <input checked="" type="checkbox"/> <input checked="" type="checkbox"/> <div style="display: flex; justify-content: space-around; width: 100%;">1234</div> </div> <div style="margin: 0 10px;">→</div> <div> ON <input type="checkbox"/> <input type="checkbox"/> <input type="checkbox"/> <input checked="" type="checkbox"/> OFF <input checked="" type="checkbox"/> <input checked="" type="checkbox"/> <input checked="" type="checkbox"/> <input type="checkbox"/> <div style="display: flex; justify-content: space-around; width: 100%;">1234</div> </div> </div>
Actual Piping Length L(m)							
L < 15	15 ≤ L < Max. length allowed						
Setting before shipment ON <input type="checkbox"/> <input type="checkbox"/> <input type="checkbox"/> <input type="checkbox"/> OFF <input checked="" type="checkbox"/> <input checked="" type="checkbox"/> <input checked="" type="checkbox"/> <input checked="" type="checkbox"/> <div style="display: flex; justify-content: space-around; width: 100%;">1234</div>	ON <input checked="" type="checkbox"/> <input type="checkbox"/> <input type="checkbox"/> <input type="checkbox"/> OFF <input type="checkbox"/> <input checked="" type="checkbox"/> <input checked="" type="checkbox"/> <input checked="" type="checkbox"/> <div style="display: flex; justify-content: space-around; width: 100%;">1234</div>						

12. FIELD SETTING

12.2 ESP setting (Ducted type only)

The static pressure can be freely adjusted by using specific wired remote controller.

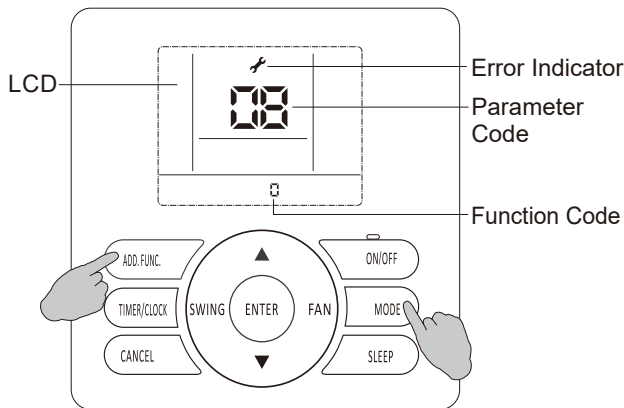

Fig 6.2

Model (Capacity Btu/h)	The Range of Static Pressure	Function Code Set
9K/12K/18K	0-0.20 in. H ₂ O (0-50Pa)	0-50 function code value equals static pressure value, more than 50 is 0.20 in. H ₂ O (50Pa), [default: 0 (0.18 in. H ₂ O or 45Pa)]
24K	0-0.40 in. H ₂ O (0-100Pa)	0-100 function code value equals static pressure value, more than 100 is 0.40 in. H ₂ O (100Pa), [default: 0 (0.18 in. H ₂ O or 45Pa)]
36K	0-0.56 in. H ₂ O (0-140Pa)	0-140 function code value equals static pressure value, more than 140 is 0.56 in. H ₂ O (140Pa), [default: 0 (0.23 in. H ₂ O or 57Pa)]

Static pressure setting:

- 1 Press and hold "MODE" button and "ADD.FUNC." button for 3 seconds, symbol ⚡ and parameter code starts blinking at the same time.
- 2 Press "▲/▼" button to adjust parameter number until "17" is displayed, and press "ENTER" button to enter system parameter adaption state, symbol ⚡ stops blinking.
- 3 Select desired parameter code 10 by pressing "▲/▼" button, and press "ENTER" button to confirm.
- 4 Select desired function code to rewrite the parameter values by pressing "▲/▼" button, and press "ENTER" button to confirm.
- 5 Press "ON/OFF" button or "CANCEL" button to quit.

12. FIELD SETTING

12.3 Indoor unit parameter revision

1) Connecting wire remote controller with indoor unit

Step 1: Removing the upper cover of the wired controller

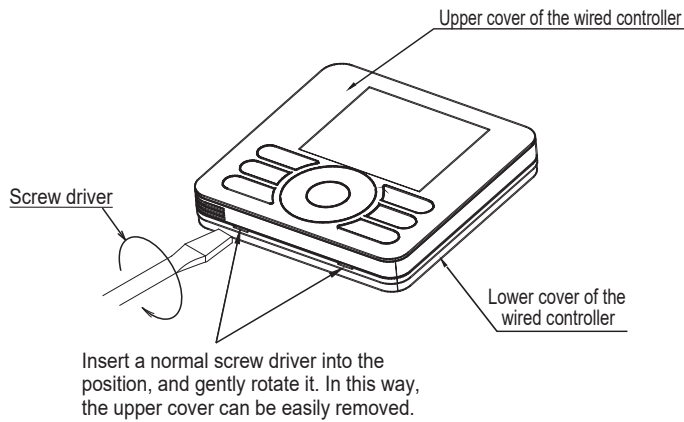

NOTE:

Control board of the remote controller is placed on upper cover. Please protect it from being scratched during removal and installation!

Step 2: Connecting wired controller with indoor unit

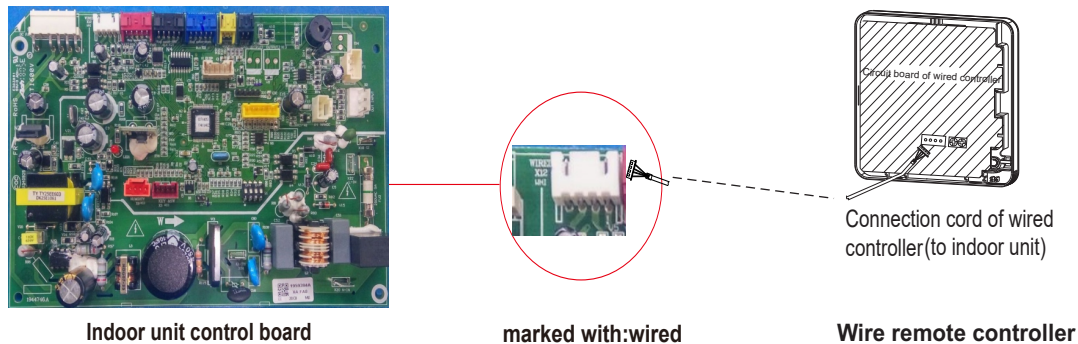

2). Changing system parameter

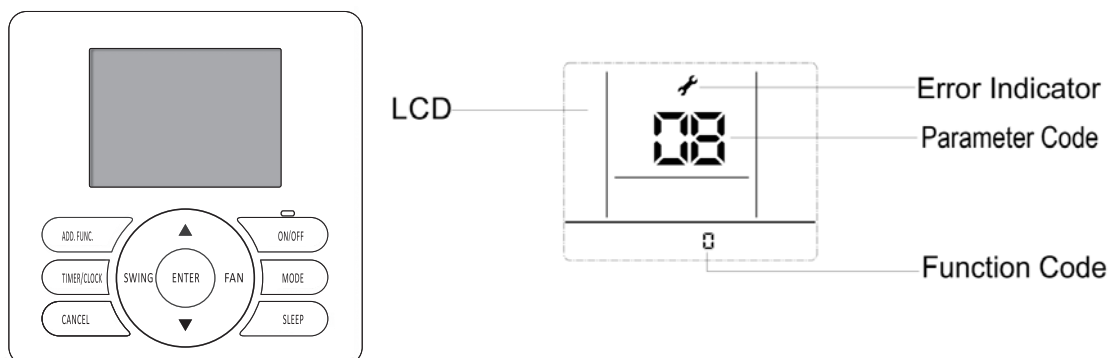

OPERATION:

- ① Hold down both "MODE" button and "ADD.FUNC." button for 3 seconds, symbol and parameter number blink at the same time.
- ② Press "▲" "▼" button to adjust parameter number until "17" is displayed. And press "ENTER" button to enter system parameter adaption state, symbol stop blinking, and parameter number blink.
- ③ Select desired parameter code by pressing "▲"/ "▼" button following the table below, and press "ENTER" button to confirm.
- ④ Select desired function code by pressing "▲"/ "▼" button, and press "ENTER" button to confirm.

12. FIELD SETTING

PARAMETER CODE	PARAMETER DESCRIPTION	PARAMETER VALUE&REPRESENTATION		NOTE
		DATA TYPE	REPRESENTATION (FUNCTION CODE)	
1	Self Recovery of Power Break	Integer	0: Cancel Self Recovery of Power Break function; 1: Self Recovery of Power Break; others: invalid	
2	Temperature Type	Integer	0: Centigrade Temperature; 1: Fahrenheit Temperature; others: invalid	
3	Temperature Display Type	Integer	0: Default display set temperature; 1: Default display room temperature; others: invalid	
4	Ratio of ambient temperature sensed by indoor temperature sensor (cooling mode)	Integer	0~10valid, more than 10 default is10 0: 0%; 1: 10%; ...; 10: 100%	0-entirely use temperature sensed by wired remote controller; 10-entirely use temperature sensed by indoor unit
5	Filter Cleaning Indication	Integer	0: Cancel Filter Cleaning prompt function; 1: Set Filter Cleaning prompt function; others: invalid	
6	Filter Clean Time Setting	Integer	0~32, more than 32 default is 32*1000h	
7	Installation Height Compensation	Integer	0~10m, more than 10m default is 10. =0,1,2: no fan speed compensation; =3: increase fan speed; =4~10: increase more fan speed.	
8	Cooling Temperature Compensation (indoor unit temperature sensor)	Integer	0 : 0°C ; 1 : -0.5°C ; 2 : -1°C ; 3 : -1.5°C ; 4 : -2°C ; 5 : -2.5°C ; 6 : -3°C ; 7 : -3.5°C ; 8 : -4°C ; 9 : -4.5°C ; 10 : -5°C.(the wired controller displays integer with the symbol)	
9	Heating Temperature Compensation (indoor unit temperature sensor)	Integer	0 : 0°C ; 1 : -0.5°C ; 2 : -1°C ; 3 : -1.5°C ; 4 : -2°C ; 5 : -2.5°C ; 6 : -3°C ; 7 : -3.5°C ; 8 : -4°C ; 9 : -4.5°C ; 10 : -5°C. (the wired controller displays integer with the symbol)	
10	Static Pressure Setting	Integer	1~240, function code=static pressure more than the limit static pressure default the limit static pressure, Default is 0 (default static pressure, related to models)	Duct type (DC motor)
12	Ratio of temperature sensed by indoor temperature sensor (Heating mode)	Integer	0~10valid, more than 10 default is10 0: 0%; 1: 10%; ...; 10: 100%	0-entirely use temperature sensed by wired remote controller; 10-entirely use temperature sensed by indoor unit
13	Temperature Adjustment-Cooling	Character	-10~10°C (Single Character with symbol)	Temperature displayed on wired controller
14	Temperature Adjustment-Heating	Character	-10~10°C (Single Character with symbol)	Temperature displayed on wired controller
25	Access control, fire protection, ON/OFF function setting	Integer	=0, Access control, fire protection functions are all invalid; =1, Access control function is valid; =2, fire protection function is valid; =3, Access control, fire protection are all valid; =4, ON/OFF function is valid.	

12. FIELD SETTING

12.4 Running parameter query

Running parameter can be referred to by 7 segment display or specified wired remote controller.

Query by wired remote controller

Operation:

1. Connect wired remote controller with indoor unit (same method as Indoor unit parameter revision)
2. Chang system parameter

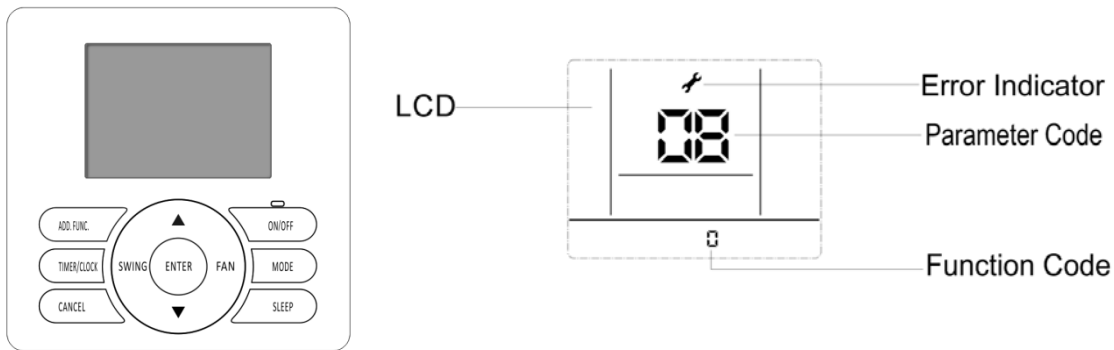

OPERATION:

- ① Hold down both "MODE" button and "ADD.FUNC." button for 3 seconds, symbol and parameter number blink at the same time.
- ② Press "▲" "▼" button to select parameter number as you need, parameter value will be displayed on the LCD.

Parameter Code	Parameter Description
06	Indoor unit air inlet temperature
07	Indoor unit coil sensor temperature
08	Outdoor unit ambient sensor temperature
09	Discharge temperature
10	Suction temperature
11	Outdoor coil temperature
12	Discharge pressure
13	Suction pressure
14	Outdoor EEV opening
15	AC current input
16	AC voltage
24	Error code
25	Drive error code
26	Indoor unit air outlet temperature
28	Compressor current
29	Indoor unit room temperature
30	Indoor unit coil inlet temperature
31	Indoor unit coil outlet temperature
32	Outdoor unit condenser inlet temperature
33	Outdoor unit condenser outlet temperature
43	Outdoor unit defrost temperature
57	Outdoor fan 1 speed
58	Outdoor fan 2 speed
60	Indoor fan speed

12. FIELD SETTING

Query by 7 segment display

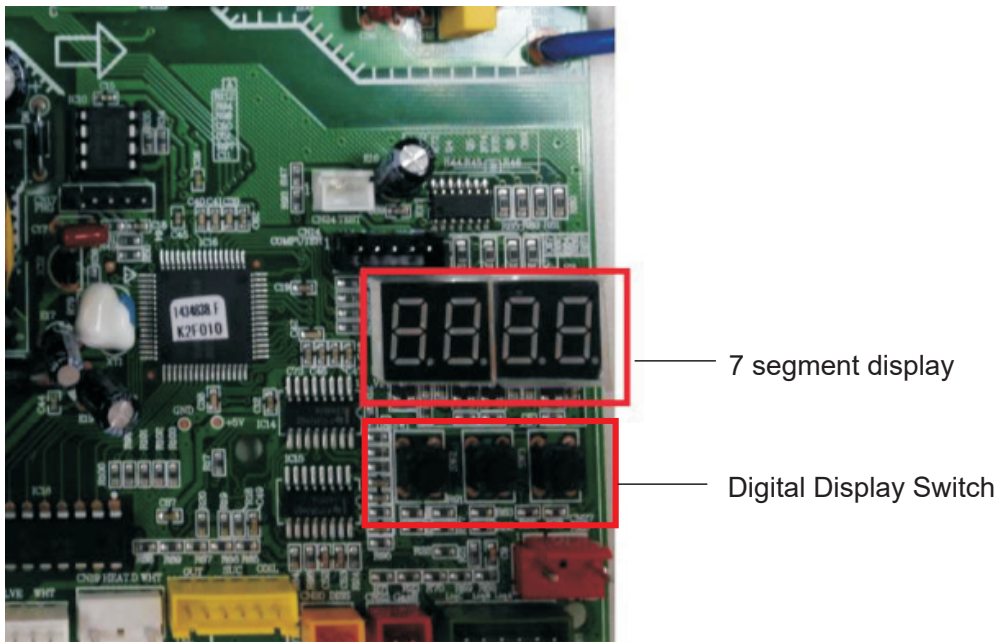

DC-Inverter outdoor control board

7 segment display Introduction

It can be used to check outdoor running parameters.

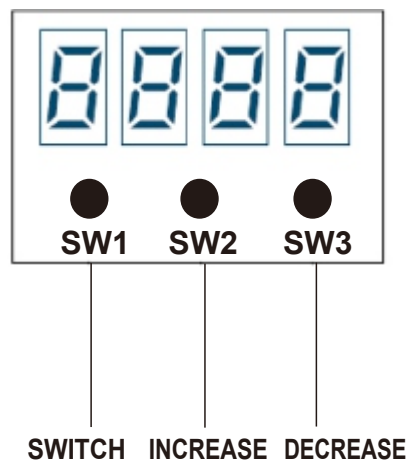

There are 3 buttons on the digital display board :

- 1) SWITCH button: Indoor parameters and outdoor parameters can be selected in turn by pressing it.
“P.”-outdoor unit parameter, “H.”-indoor unit parameter;
- 2) INCREASE button: Each time it is pressed, the number rises by 1,hold down it, the number will be rapidly increased;
- 3) DECREASE button: Each time it is pressed, the number lowers by 1,hold down it, the number will be rapidly decreased.
- 4) The parameters will be displayed after 3s when the checking numbers are selected.

12. FIELD SETTING

Parameters can be checked in the following table below.

Parameter code	Descriptions
0	Protecting Code or Fault code
P.1	Target Frequency
P.2	Driving Frequency
P.4	Outdoor EEV Opening
P.5	Outdoor EEV Target Opening
P.6	Upper DC Motor Revolving Speed
P.8	AC Input Voltage
P.9	Current
P.10	Modular Temperature
P.11	Capacity Needed
P.12	Modular Fault
P.20	Outdoor Ambient Temperature
P.21	Outdoor Coil Temperature
P.22	Outdoor Defrost Temperature
P.23	Suction Temperature
P.24	Discharge Temperature
H.1	Indoor Unit Fault
H.2	Indoor Ambient Temperature
H.3	Indoor Coil Temperature
H.4	Indoor Setting Temperature

12. FIELD SETTING

12.5 Instructions for the function setting of access control, fire protection

12.5.1 Factory setting

In case of using or canceling the access control / fire protection function, use the wired controller to modify the parameters of indoor unit.

NOTE: please refer to "Site Setting" section in TC Manual for how to use the wired controller to modify the parameters of indoor unit.

12.5.2 Function introduction

(1) Access control: a kind of control mode to control the machine startup & shutdown based on the on & off state of the access control port.

(2) Fire protection: a kind of control mode to control the machine startup & shutdown based on the on & off state of the fire protection port.

12.5.3. Function setting

(1) Hardware connection

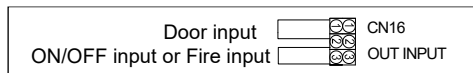

Figure 1 electrical wiring diagram



Figure 1 short wiring



Figure 3 main control board

3 pins of the OUT INPUT CN16 socket shown in the electrical wiring diagram of Figure 1 are tacitly approved to be in short circuit state under the factory state (an external short circuit plug shown as Figure 2), and the OUT INPUT CN16 socket of main control board is shown as Figure 3.

(Illustration: the socket number in circuit is subject to the actual serial number of PCB.)

- 1) When using the door lock function, the user cuts off the red short wire shown in Figure 2 and accesses the door lock control switch (supplied by user), and the connecting wire should be 22AWG or above specification. The door lock switch is closed under normal conditions and off under abnormal conditions.
- 2) When using the fire protection function, the user cuts off the white short wire shown in Figure 2 and accesses the fire protection control switch (supplied by user), and the connecting wire should be 22AWG or above specification. The protection control switch is closed under normal conditions and off under abnormal conditions.

(2) Timing sequence description:

Access control:

- 1) Control of entrance card disconnection: the air conditioner shall be shut down after the access control signal is disconnected for 30 seconds. In this state, the indoor unit can't be started. If the user performs starting operation, the wired controller shall not respond and displays power-off.

12. FIELD SETTING

2) Control of entrance card connection: after the short circuit of entrance card interface, release power-on restrictions, the wired controller maintains power-off and the startup & shutdown control is effective.

(2) Fire protection

1) Access to fire protection: the air conditioner shall be shut down and not blow waste cold or warm air after the access control signal is disconnected for 3 seconds. In this state, the indoor unit can't be started. If the user performs starting operation, the wired controller shall not respond and displays power-off.

2) Cancellation of fire protection: after the short circuit of fire protection signal, release power-on restrictions, the wired controller maintains power-off and the startup & shutdown control is effective.

3.3 Relative priorities of instructions

Access control and fire prevention functions shall not affect each other.

NOTE:

Figures in the manual are only simple representation of the control board, it may not comply with the appearance that you purchased.

12. FIELD SETTING

12.6 Instructions for the function setting of ON/OFF

- (1) The factory setting of access control and fire protection functions of the IDU are activated, while On/off functions are switched off. During on-site installation, access control and fire protection are available when you connect the corresponding cables correctly.
- (2) The On/off function can switch on or off the air conditioner by a third-party controller, and activates the On/off function by setting the relevant parameters of the wired controller. When the On/off function is activated, the access control and fire protection functions will be disabled. On/off switch has the highest priority. Once started up by on/off switch, the unit will not be able to be switched off by wired controller or remote-controller. Once power off by on/off switch, the unit will not be able to be started up by wired controller, remote-controller. But other functions are still available by using wired controller, remote-controller.
- (3) There are 3 different IDU control boards in figure 1, figure 2, all of them have corresponding hardware ports with access control, fire protection and On/off functions. On/off function signal INPUT port is the original fire function signal INPUT port (white cable), as shown in figure 1, figure 2. The unit will be started up when the white cable is connected, and the unit will be shut down when the white cable is disconnected. If other functions such as setting mode and temperature are needed, it should be realized by wired controller, remote-controller. The OUTPUT terminal in figure 1, figure 2 outputs 12V DC voltage signal (blue line is positive and brown line is negative) to a third-party controller when the unit has fault. And OUTPUT terminal in figure 1, figure 2 and will not OUTPUT the signal when there is no fault.



Output Input

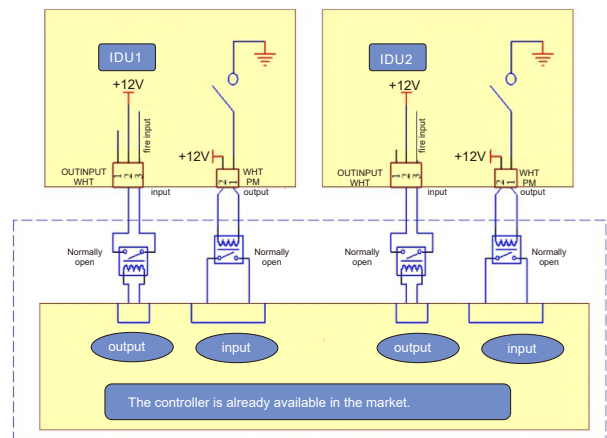
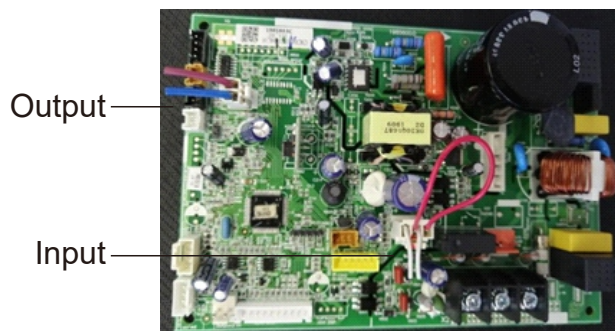

13. PIPING WORK AND REFRIGERANT CHARGE

13. Piping work and refrigerant charge

13.1 MAX.length allowed

Model	Max. Pipe length (L)	Max. Height difference (H)	Add. Refrigerant [exceed 25 ft. (7.6m)]
9K/12K	82 ft. (25m)	33 ft. (10m)	0.161 oz/ft (15g/m)
18K	98 ft. (30m)	49 ft. (15m)	0.161 oz/ft (15g/m)
24K/36K	164 ft. (50m)	98 ft. (30m)	0.376 oz/ft (35g/m)

13.2 Oil trap

When the indoor unit is lower than outdoor unit and height difference is larger than 16.4 ft (5m), set an oil trap every 16.4 ft (5m) (height difference) on suction piping.

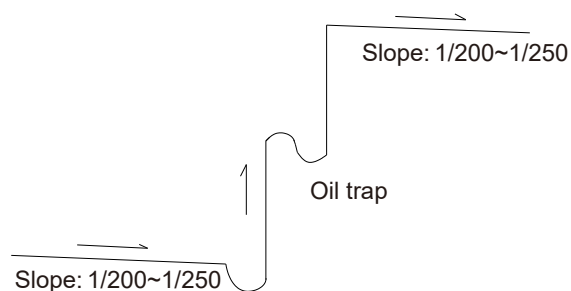

NOTE:

- 1) To avoid storing too much oil in the oil trap, the oil trap should be as short as possible.
- 2) The horizontal piping should slope down along the refrigerant flow direction, to bring the oil back to compressor, the slope is about 1/200 to 1/250.
- 3) In order to ensure cooling/heating performance better, the refrigerant piping should be as short and straight as possible.

13. PIPING WORK AND REFRIGERANT CHARGE

13.3 Air tight test

Do use nitrogen when performing air-tight test.

Connect the gauge manifold using charging hoses with a nitrogen cylinder to the check joints of the liquid line and the gas line stop valves. Perform the air-tight test. Don't open the gas line stop valves. Apply nitrogen gas pressure of 4.3MPa. Check for any gas leakage at the flare nut connections, or brazed parts by gas leak detector or foaming agent. It is OK if gas pressure does not decrease. After the air tight test, release nitrogen gas.

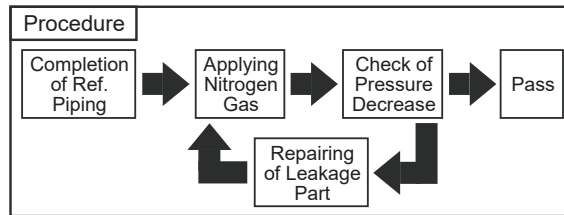

Air tight procedure

13.4 Additional refrigerant charge

Although refrigerant has been charged into this unit, additional refrigerant charge is required according to the piping length.

- The additional refrigerant precharge quantity should be determined and charged into the system according to the following procedure.
- Record the additional refrigerant quantity in order to facilitate maintenance and servicing activities.

Refrigerant charge before shipment (W0 (kg))

W0 is the outdoor unit refrigerant charge before shipment;

Xg is additional refrigerant outdoor unit needed to charge according to piping length during installation.

Model	Refrigerant precharged before shipment (W0(oz/g))	Total refrigerant pipe length	
		0m~25ft (7.6m)	Longer than 25ft (7.6m)
9K	33.5/0.95	0g	Additional refrigerant charge= (L-24.6)×0.161 oz/ft
12K	45.9/1.3	0g	
18K	56.44/1.6	0g	
24K	91.7/2.6	0g	Additional refrigerant charge= (L-24.6)×0.376 oz/ft
36K	111.2/3.15	0g	

14. INSTALLATION TOOLS AND INSTALLATION FLOW CHART

14. Installation tools and installation flow chart

14.1 Necessary tools and instrument list for installation

No.	Tool	No.	Tool	No.	Tool	No.	Tool
1	Handsaw	6	Copper Pipe Bender	11	Spanner	16	Leveler
2	Phillips Screwdriver	7	Manual Water Pump	12	Charging Cylinder	17	Clamper for Solderless Terminals
3	Vacuum Pump	8	Pipe Cutter	13	Gauge Manifold	18	Hoist (for Indoor Unit)
4	Refrigerant Gas Hose	9	Brazing Kit	14	Cutter for Wires	19	Ammeter
5	Megohmmeter	10	Hexagon Wrench	15	Gas Leak Detector	20	Voltage Meter

Use specified tools and measuring instruments only for the new refrigerant.

◇: Interchangeability is available with R410A

●: Only for Refrigerant R32

×: Prohibited

◆: Only for Refrigerant R22

Measuring Instrument and Tool for R410A		R32	R22	Reason of Non-Interchangeability and Attention (*: Strictly Required)	Use
Refrigerant Pipe	Pipe Cutter Chamfering Reamer	◇	◇	-	Cutting Pipe Removing Burrs
	Flaring Tool	◇	◇	* The flaring tools for R32 are applicable to R22/R410A. * If using flaring tube, make dimension of tube larger for R410A. * In case of material 1/2H, flaring is not available.	Flaring for Tubes
	Pipe Bender	◇	◇	* In case of material 1/2H, bending is not available. Use elbow for bend and braze.	Bending
	Expanding Tool	◇	◇	* In case of material 1/2H, expanding of tube is not available. Use socket for connecting tube.	Expanding Tubes
	Torque Wrench	◇	×	* For ϕ 1/2, ϕ 5/8, spanner size is up 2mm.	Connection of Flare Nut
		◇	◇	* For ϕ 1/4, ϕ 3/8, ϕ 3/4, spanner size is the same.	
	Brazing Tool	◇	◇	* Perform correct brazing work.	Brazing for Tubes
	Nitrogen Gas	◇	◇	* Strict Control against Contamin (Blow nitrogen during brazing.)	Prevention from Oxidation during
Lubrication Oil (for Flare Surface)	●	◆	* Use a synthetic oil which is equivalent to the oil used in the refrigeration cycle. * Synthetic oil absorbs moisture quickly.	Applying Oil to the Flared Surface	
Vacuum Drying & Refrigerant Charge	Refrigerant Cylinder	×	×	* Check refrigerant cylinder color. * Liquid refrigerant charging is required regarding zeotropic refrigerant. * Use the weight scale.	Refrigerant Charging
	Vacuum Pump	◇	◇	* The current ones are applicable. However, it is required to mount a vacuum pump adapter which can prevent from reverse flow when a vacuum pump stops, resulting in no reverse oil flow.	Vacuum Pumping
	Adapter for Vacuum Pump	◇	◆		
	Manifold Valve	◇	◆	* No interchangeability is available due to higher pressures when compared with R22. * Do not use current ones to the different refrigerant. If used, mineral oil will flow into the cycle and cause sludges, resulting in clogging or compressor failure.	Vacuum Pumping, Vacuum Holding, Refrigerant Charging and Check of Pressures
	Charging Hose	◇	×	* Connection diameter is different; R32/R410A: UNF1/2, R22: UNF7/16.	
	Weight Scale	◇	◇		Measuring Instrument for Refrigerant Charging
	Refrigerant Gas Leakage Detector	×	×	* The current gas leakage detector (R22) is not applicable due to different detecting method.	Gas Leakage Check

14. INSTALLATION TOOLS AND INSTALLATION FLOW CHART

14.2 Installation flow chart

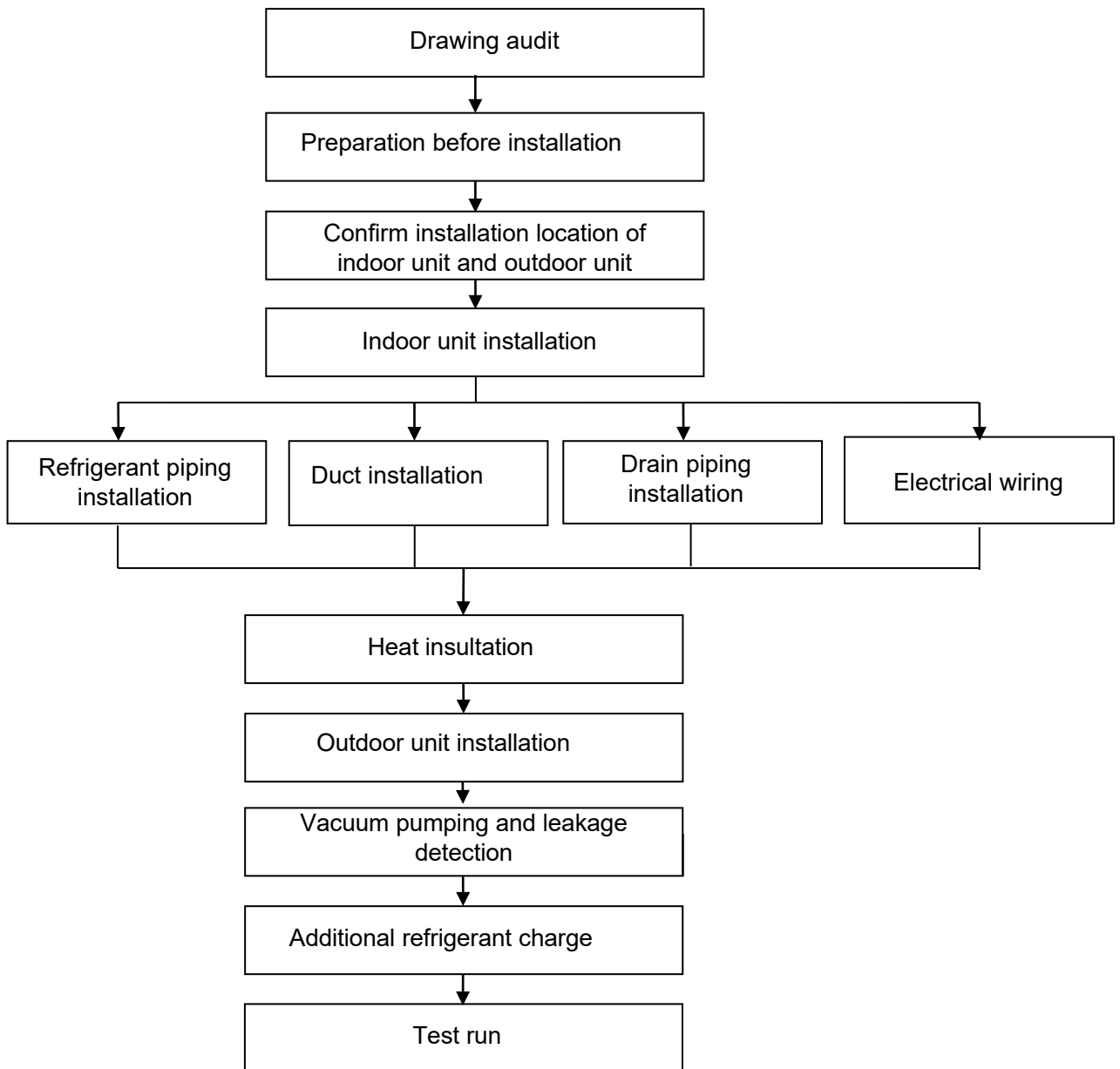

Note: This flow is only for reference; For details, see installation manual section.

15. CONTROL MODE

15. Control mode

15.1 Indoor unit mode control

1. Main general technical parameters

- (1) Remote receiver distance: 8 m.
- (2) Remote receiver angle: Less than 80 degrees.
- (3) Temperature control accuracy: $\pm 1^{\circ}\text{C}$.
- (4) Time error: Less than 1%.

2. Functions of the control function

2.1 Emergency switch

Pressing the emergency button can start or stop the unit, or the unit can start up according to the automatic mode of operation. Press this button to turn ON the unit, the unit will run in auto mode, and press it again to turn the unit off. When the unit is OFF, press and hold the emergency switch for 5 seconds, with 3 beeps, the indoor unit would turn to emergency running. In such situation, the unit would be forced to turn to cooling operation with high speed, the flaps sweeping and the unit's operation is irrelevant with room temperature.

If a remote signal has been received during the emergency run, the machine will operate upon the command of such a remote signal.

2.2 Operator-machine communication

The air conditioner and remote controller is provided with a temperature sensor. The remote controller on the temperature sensor detects the default settings of room temperature. If the indoor control unit has not received remote control signal for a long time, it will automatically switch to the air conditioner body temperature sensor.

2.3 Timer function

(1) Timer on

When set to start in a time by the remote controller, the air conditioner starts in the timer on condition. When the set time is up, the air conditioner will turn on and operates in the preset conditions after receiving a signal from the remote controller. If the air conditioner has not received a signal from the remote controller when the set time is up, it will automatically start and operate in the preset conditions.

(2) Timer off

When set to stop in a set time by the remote controller, the air conditioner will start in the timer off condition. When the set time is up, the air conditioner will turn off after receiving a signal from the remote controller. If the air conditioner has not received a signal from the remote controller when the set time is up, it will turn off automatically.

(3) Neither the turning on nor turning off operation will cancel the timer function.

15. CONTROL MODE

2.4 Sleep

- (1) In the heating, cooling or dehumidifying mode, press the "Sleep" button on the remote controller to start or cancel the sleep function in turn, and at the same time the sleep icon on the display screen will be on or off accordingly.
- (2) In the heating mode, the set temperature will decrease automatically after the sleep function is started.
- (3) In the cooling mode, the set temperature will rise automatically after the sleep function is started.
- (4) By default, the setting is to cancel the sleep function. Turning off the unit will also cancel the sleep function.

2.5 Highly efficient run function (only for some remote controller)

In Cooling, Dehumidification, Fan mode, press the "HIGH POWER " to enter the refrigeration mode, set the temperature automatically adjusting to lowest temp; the Fan speed is powerful speed; frequency is high frequency operation.

In heating mode, press the "HIGH POWER" to enter the refrigeration mode, set the temperature automatically to adjust to highest temp.; the Fan speed is powerful speed; frequency is high frequency operation.

Mute function (only for some remote controller)

In the indoor unit operation mode, you may turn on or turn off mute function with mute key. The air conditioner will run with mute fan speed in mute mode.

2.6 Prevention cooling wind prevention mode

In the heating-run, to prevent the indoor fan from blowing cold air, the indoor fan will stop or run slowly until the coil is warm.

2.7 Blowing waste heating and waste cooling function

In the heating mode, when the air conditioner is turned off, the indoor heat exchanger temperature is still higher, so the air conditioner will run the waste heat.

In the cooling and dehumidification mode, after the compressor stops, indoor unit will continue to set the speed of operation for a period of time.

2.8 Dehumidifying method:

If remote control setting is in dehumidifying mode, indoor unit is forced to run at low speed (high power key or a strong bond also maintains a low wind speed), and the outdoor unit runs according to the refrigeration mode operation.

2.9 Auto re-start from power break

When the power supply is recovered after a break, all presets are still effective and the air-conditioner can run according to the previous setting.

How to set/cancel:

It can be set /canceled with wired remote controller.

For details, see internal control parameter adjustment.

15. CONTROL MODE

2.10 Fault code

The fault code can be shown by LED lamps or will display on the wired controller.

2.11 Filter cleaning

FC will light up when air filter is clogged with dust.

How to set/cancel: It can be set /canceled with wired remote controller.

For details, see internal control parameter adjustment.

15. CONTROL MODE

15.2 Outdoor unit mode control

Control function

1. Cooling Anti-Freeze Protection

The indoor coil sensor functions as real time temperature detector of evaporator. It prevents the indoor unit evaporator temperature becoming too low. If the indoor coil temperature is too low, the compressor will automatically start protection mode.

2. Overload Protection

To prevent system overload caused by excessive pressure, the machine will implement real-time detection when outdoor coil temperature is too high during cooling mode or indoor coil temperature is too high during heating mode.

3. Exhaust temperature protection

To prevent deterioration due to high exhaust temperature of compressor, the machine will realize the real-time detection of the exhaust gas temperature. If the temperature is too high, the compressor provides automatic protection.

4. Oil-return Control

When the compressor runs at low frequencies for a long time, the control system will start the oil-return mechanism. The oil in the system returns to the compressor.

5. Operation Mode

Air conditioning mode is the operation mode set by users through remote controller, four modes are available: cooling, heating, dehumidification, and fan mode.

6. Four-way Valve Control

Four-way valve of the outdoor unit shuts down when cooling and defrosting but starts when heating. During the heating process, the four-way valve stops working for a period of time after compressor is disconnected.

7. Start-up Protection

To prevent compressor from restarting frequently when the system pressure has not been completely balanced, it cannot be restarted within 3 minutes.

8. Pressure Protection

When the pressure increases to a preset value, the pressure switch will automatically protect the unit. The compressor will stop and report the fault code protection.

16. SENSOR PARAMETER

16. Sensor parameter

1. THE PARAMETER OF OUTDOOR COMPRESSOR DISCHARGE TEMPERATURE SENSOR:

($R_0=187.25K\pm 6.3\%$; $R_{100}=3.77K\pm 2.5K$; $B0/100=3979K\pm 1\%$)

T [°C]	Rmin [KΩ]	Rnom [KΩ]	Rmax [KΩ]	DR(MIN)%	DR(MAX)%
-30	908.2603	985.5274	1065.1210	-7.84	7.47
-29	855.3955	927.6043	1001.9150	-7.78	7.42
-28	805.9244	873.4324	924.8368	-7.73	5.56
-27	759.6097	822.7471	887.5944	-7.67	7.31
-26	716.2320	775.3041	835.9165	-7.62	7.25
-25	675.5881	730.8775	787.5529	-7.56	7.20
-24	637.4902	689.2583	742.2720	-7.51	7.14
-23	601.7645	650.2533	699.8601	-7.46	7.09
-22	568.2499	613.6835	660.1191	-7.40	7.03
-21	536.7970	579.3832	622.8658	-7.35	6.98
-20	507.2676	547.1989	587.9307	-7.30	6.93
-19	497.5332	516.9882	555.1565	-3.76	6.88
-18	453.4748	488.6192	524.3977	-7.19	6.82
-17	428.9819	461.9693	495.5191	-7.14	6.77
-16	405.9517	436.9251	486.3954	-7.09	10.17
-15	384.2888	413.3808	442.9105	-7.04	6.67
-14	363.9047	391.2386	418.9563	-6.99	6.62
-13	344.7169	370.4072	396.4325	-6.94	6.56
-12	326.6497	350.8019	375.2461	-6.88	6.51
-11	309.6286	332.3441	355.3104	-6.83	6.46
-10	293.5903	314.9620	336.5448	-6.79	6.41
-9	278.4719	298.5822	318.3744	-6.74	6.22
-8	264.2156	283.1464	302.2294	-6.69	6.31
-7	250.7678	268.5936	286.5448	-6.64	6.26
-6	238.0783	254.8686	271.7603	-6.59	6.22
-5	226.1003	241.9200	257.8193	-6.54	6.17
-4	214.7903	229.6997	244.6593	-6.49	6.11
-3	204.1073	218.1630	232.2612	-6.44	6.07
-2	194.0135	207.2681	220.5495	-6.39	6.02
-1	184.4732	196.9759	209.4913	-6.35	5.97
0	175.4533	187.2500	199.0468	-6.30	5.93
1	166.8952	178.0255	189.1529	-6.25	5.88
2	158.8023	169.3067	179.8058	-6.20	5.84
3	151.1467	161.0633	170.9724	-6.16	5.80
4	143.9026	153.2667	162.6216	-6.11	5.75
5	137.0455	145.8905	154.7246	-6.06	5.71
6	130.5528	138.9097	147.2544	-6.02	5.67
7	124.4033	132.3011	140.1856	-5.97	5.62
8	118.5769	126.0429	133.4946	-5.92	5.58
9	113.0550	120.1146	127.1591	-5.88	5.54
10	107.8202	114.4973	121.1586	-5.83	5.50
11	102.8560	109.1728	115.4734	-5.79	5.46
12	98.1470	104.1246	110.0855	-5.74	5.41
13	93.6787	99.3367	104.9778	-5.70	5.37
14	89.4378	94.7946	100.1342	-5.65	5.33
15	85.4114	90.4842	95.5398	-5.61	5.29
16	81.5875	86.3926	91.1805	-5.56	5.25
17	77.9551	82.5076	87.0430	-5.52	5.21
18	74.5034	78.8177	83.1150	-5.47	5.17

16. SENSOR PARAMETER

T [°C]	Rmin [KΩ]	Rnom [KΩ]	Rmax [KΩ]	DR(MIN)%	DR(MAX)%
19	71.2227	75.3122	79.3848	-5.43	5.13
20	68.1036	71.9808	75.8414	-5.39	5.09
21	65.1373	68.8141	72.4746	-5.34	5.05
22	62.3155	65.8032	69.2746	-5.30	5.01
23	59.6306	62.9395	66.2324	-5.26	4.97
24	57.0752	60.2152	63.3395	-5.21	4.93
25	54.6424	57.6227	60.5877	-5.17	4.89
26	52.3258	55.1551	57.9695	-5.13	4.85
27	50.1192	52.8058	55.4778	-5.09	4.82
28	48.0168	50.5684	53.1058	-5.05	4.78
29	46.0133	48.4371	50.8472	-5.00	4.74
30	44.1034	46.4046	48.6960	-4.96	4.71
31	42.2825	44.4711	46.6466	-4.92	4.66
32	40.5458	42.6261	44.6937	-4.88	4.63
33	38.8891	40.8668	42.8323	-4.84	4.59
34	37.3084	39.1890	41.0576	-4.80	4.55
35	35.7998	37.5883	39.3653	-4.76	4.51
36	34.3596	36.0609	37.7511	-4.72	4.48
37	32.9844	34.6030	36.2109	-4.68	4.44
38	31.6710	33.2113	34.7412	-4.64	4.40
39	30.4164	31.8823	33.3383	-4.60	4.37
40	29.2176	30.6130	31.9988	-4.56	4.33
41	28.0718	29.4004	30.7197	-4.52	4.29
42	26.9765	28.2417	29.4979	-4.48	4.26
43	25.9293	27.1342	28.3306	-4.44	4.22
44	24.9277	26.0755	27.2150	-4.40	4.19
45	23.9697	25.0632	26.1488	-4.36	4.15
46	23.0530	24.0950	25.1293	-4.32	4.12
47	22.1757	23.1688	24.1545	-4.29	4.08
48	21.3360	22.2826	23.2221	-4.25	4.05
49	20.5321	21.4345	22.3301	-4.21	4.01
50	19.7623	20.6226	21.4766	-4.17	3.98
51	19.0261	19.8468	20.6612	-4.14	3.94
52	18.3211	19.1040	19.8808	-4.10	3.91
53	17.6458	18.3926	19.1338	-4.06	3.87
54	16.9986	17.7113	18.4185	-4.02	3.84
55	16.3784	17.0537	17.7335	-3.96	3.83
56	15.7839	16.4332	17.0774	-3.95	3.77
57	15.2139	15.8338	16.4488	-3.92	3.74
58	14.6673	15.2592	15.8464	-3.88	3.71
59	14.1430	14.7083	15.2690	-3.84	3.67
60	13.6400	14.1799	14.7154	-3.81	3.64
61	13.1573	13.6730	14.1846	-3.77	3.61
62	12.6941	13.1868	13.6756	-3.74	3.57
63	12.2494	12.7202	13.1872	-3.70	3.54
64	11.8224	12.2723	12.7186	-3.67	3.51
65	11.4124	11.8424	12.2690	-3.63	3.48
66	11.0185	11.4295	11.8373	-3.60	3.45
67	10.6401	11.0331	11.4230	-3.56	3.41
68	10.2765	10.6522	11.0251	-3.53	3.38
69	9.9271	10.2863	10.6429	-3.49	3.35
70	9.5912	9.9348	10.2756	-3.46	3.32
71	9.2682	9.5968	9.9231	-3.42	3.29
72	8.9576	9.2720	9.5841	-3.39	3.26
73	8.6589	8.9597	9.2583	-3.36	3.23
74	8.3716	8.6594	8.9451	-3.32	3.19

16. SENSOR PARAMETER

T [°C]	Rmin [KΩ]	Rnom [KΩ]	Rmax [KΩ]	DR(MIN)%	DR(MAX)%
75	8.0951	8.3705	8.6440	-3.29	3.16
76	7.8290	8.0926	8.3544	-3.26	3.13
77	7.5730	7.8252	8.0758	-3.22	3.10
78	7.3264	7.5679	7.8078	-3.19	3.07
79	7.0891	7.3202	7.5499	-3.16	3.04
80	6.8605	7.0818	7.3018	-3.12	3.01
81	6.6403	6.8522	7.0629	-3.09	2.98
82	6.4282	6.6311	6.8329	-3.06	2.95
83	6.2239	6.4182	6.6115	-3.03	2.92
84	6.0269	6.2131	6.3982	-3.00	2.89
85	5.8371	6.0154	6.1928	-2.96	2.86
86	5.6542	5.8249	5.9949	-2.93	2.84
87	5.4777	5.6413	5.8042	-2.90	2.81
88	5.3076	5.4644	5.6205	-2.87	2.78
89	5.1435	5.2937	5.4433	-2.84	2.75
90	4.9853	5.1292	5.2726	-2.81	2.72
91	4.8326	4.9705	5.1079	-2.77	2.69
92	4.6852	4.8174	4.9492	-2.74	2.66
93	4.5430	4.6697	4.7960	-2.71	2.63
94	4.4058	4.5272	4.6483	-2.68	2.61
95	4.2733	4.3896	4.5058	-2.65	2.58
96	4.1453	4.2568	4.3683	-2.62	2.55
97	4.0218	4.1287	4.2355	-2.59	2.52
98	3.9024	4.0049	4.1074	-2.56	2.50
99	3.7872	3.8854	3.9837	-2.53	2.47
100	3.6758	3.7700	3.8643	-2.50	2.44
101	3.5661	3.6585	3.7512	-2.53	2.47
102	3.4601	3.5509	3.6419	-2.56	2.50
103	3.3577	3.4468	3.5362	-2.59	2.53
104	3.2588	3.3463	3.4341	-2.61	2.56
105	3.1632	3.2491	3.3353	-2.64	2.58
106	3.0708	3.1551	3.2398	-2.67	2.61
107	2.9816	3.0643	3.1475	-2.70	2.64
108	2.8953	2.9765	3.0582	-2.73	2.67
109	2.8118	2.8915	2.9717	-2.76	2.70
110	2.7311	2.8093	2.8881	-2.78	2.73
111	2.6531	2.7299	2.8072	-2.81	2.75
112	2.5776	2.6530	2.7289	-2.84	2.78
113	2.5046	2.5785	2.6531	-2.87	2.81
114	2.4340	2.5065	2.5798	-2.89	2.84
115	2.3656	2.4368	2.5087	-2.92	2.87
116	2.2995	2.3693	2.4400	-2.95	2.90
117	2.2354	2.3040	2.3733	-2.98	2.92
118	2.1734	2.2407	2.3088	-3.00	2.95
119	2.1134	2.1795	2.2463	-3.03	2.97
120	2.0553	2.1201	2.1858	-3.06	3.01
121	1.9991	2.0626	2.1271	-3.08	3.03
122	1.9446	2.0070	2.0702	-3.11	3.05
123	1.8918	1.9530	2.0151	-3.13	3.08
124	1.8406	1.9007	1.9617	-3.16	3.11
125	1.7911	1.8500	1.9099	-3.18	3.14
126	1.7430	1.8009	1.8597	-3.22	3.16
127	1.6965	1.7533	1.8110	-3.24	3.19
128	1.6514	1.7071	1.7638	-3.26	3.21
129	1.6076	1.6623	1.7180	-3.29	3.24
130	1.5652	1.6189	1.6736	-3.32	3.27

16. SENSOR PARAMETER

2. THE PARAMETER OF THE OTHER SENSOR IN INDOOR AND OUTDOOR UNIT:

($R_0=15K\pm 2\%$; $B0/100=3450K\pm 2\%$)

T [°C]	Rmin [KΩ]	Rnom [KΩ]	Rmax [KΩ]	DR(MIN)%	DR(MAX)%
-30	60.78	64.77	68.99	-6.16	6.12
-29	57.75	61.36	65.16	-5.88	5.83
-28	54.89	58.15	61.58	-5.61	5.57
-27	52.19	55.14	58.23	-5.35	5.31
-26	49.63	52.30	55.08	-5.11	5.05
-25	47.21	49.62	52.13	-4.86	4.81
-24	44.92	47.10	49.37	-4.63	4.60
-23	42.76	44.73	46.78	-4.40	4.38
-22	40.71	42.49	44.34	-4.19	4.17
-21	38.77	40.38	42.05	-3.99	3.97
-20	36.93	38.39	39.90	-3.80	3.78
-19	35.18	36.51	37.87	-3.64	3.59
-18	33.53	34.74	35.97	-3.48	3.42
-17	31.96	33.06	34.17	-3.33	3.25
-16	30.48	31.47	32.49	-3.15	3.14
-15	29.07	29.97	30.89	-3.00	2.98
-14	27.73	28.56	29.39	-2.91	2.82
-13	26.46	27.22	27.98	-2.79	2.72
-12	25.26	25.95	26.64	-2.66	2.59
-11	24.11	24.75	25.38	-2.59	2.48
-10	23.03	23.61	24.19	-2.46	2.40
-9	21.99	22.53	23.06	-2.40	2.30
-8	21.01	21.51	22.00	-2.32	2.23
-7	20.08	20.54	20.99	-2.24	2.14
-6	19.19	19.62	20.04	-2.19	2.10
-5	18.35	18.74	19.14	-2.08	2.09
-4	17.55	17.92	18.29	-2.06	2.02
-3	16.78	17.13	17.48	-2.04	2.00
-2	16.06	16.38	16.71	-1.95	1.97
-1	15.36	15.67	15.98	-1.98	1.94
0	14.70	15.00	15.29	-2.00	1.90
1	14.08	14.36	14.64	-1.95	1.91
2	13.48	13.75	14.02	-1.96	1.93
3	12.91	13.17	13.43	-1.97	1.94
4	12.36	12.62	12.87	-2.06	1.94
5	11.85	12.09	12.34	-1.99	2.03
6	11.35	11.59	11.83	-2.07	2.03
7	10.88	11.11	11.35	-2.07	2.11
8	10.43	10.66	10.89	-2.16	2.11
9	9.999	10.230	10.450	-2.26	2.11
10	9.590	9.816	10.040	-2.30	2.23
11	9.199	9.422	9.647	-2.37	2.33
12	8.826	9.047	9.269	-2.44	2.40
13	8.470	8.689	8.910	-2.52	2.48
14	8.129	8.347	8.567	-2.61	2.57
15	7.804	8.021	8.240	-2.71	2.66
16	7.493	7.709	7.928	-2.80	2.76
17	7.196	7.412	7.630	-2.91	2.86
18	6.912	7.127	7.346	-3.02	2.98
19	6.640	6.855	7.074	-3.14	3.10
20	6.381	6.595	6.815	-3.24	3.23
21	6.132	6.347	6.567	-3.39	3.35
22	5.894	6.109	6.330	-3.52	3.49

16. SENSOR PARAMETER

T [°C]	Rmin [KΩ]	Rnom [KΩ]	Rmax [KΩ]	DR(MIN)%	DR(MAX)%
23	5.667	5.882	6.103	-3.66	3.62
24	5.449	5.664	5.886	-3.80	3.77
25	5.240	5.456	5.678	-3.96	3.91
26	5.048	5.260	5.478	-4.03	3.98
27	4.864	5.072	5.286	-4.10	4.05
28	4.687	4.891	5.101	-4.17	4.12
29	4.517	4.717	4.924	-4.24	4.20
30	4.355	4.550	4.753	-4.29	4.27
31	4.198	4.390	4.589	-4.37	4.34
32	4.048	4.236	4.431	-4.44	4.40
33	3.904	4.089	4.280	-4.52	4.46
34	3.766	3.946	4.134	-4.56	4.55
35	3.663	3.810	3.994	-3.86	4.61
36	3.506	3.679	3.859	-4.70	4.66
37	3.383	3.552	3.729	-4.76	4.75
38	3.265	3.431	3.604	-4.84	4.80
39	3.152	3.314	3.484	-4.89	4.88
40	3.043	3.202	3.368	-4.97	4.93
41	2.938	3.094	3.257	-5.04	5.00
42	2.838	2.990	3.149	-5.08	5.05
43	2.741	2.890	3.046	-5.16	5.12
44	2.648	2.793	2.946	-5.19	5.19
45	2.558	2.701	2.850	-5.29	5.23
46	2.472	2.611	2.758	-5.32	5.33
47	2.389	2.525	2.669	-5.39	5.40
48	2.309	2.443	2.583	-5.49	5.42
49	2.232	2.363	2.500	-5.54	5.48
50	2.158	2.286	2.421	-5.60	5.58
51	2.087	2.212	2.344	-5.65	5.63
52	2.018	2.140	2.269	-5.70	5.69
53	1.952	2.072	2.198	-5.79	5.73
54	1.888	2.005	2.129	-5.84	5.82
55	1.827	1.941	2.062	-5.87	5.87
56	1.767	1.880	1.998	-6.01	5.91
57	1.710	1.820	1.936	-6.04	5.99
58	1.655	1.763	1.876	-6.13	6.02
59	1.602	1.707	1.818	-6.15	6.11
60	1.551	1.654	1.762	-6.23	6.13
61	1.502	1.602	1.709	-6.24	6.26
62	1.452	1.553	1.657	-6.50	6.28
63	1.409	1.505	1.606	-6.38	6.29
64	1.364	1.458	1.558	-6.45	6.42
65	1.322	1.413	1.511	-6.44	6.49
66	1.280	1.370	1.466	-6.57	6.55
67	1.241	1.328	1.422	-6.55	6.61
68	1.202	1.288	1.379	-6.68	6.60
69	1.165	1.249	1.339	-6.73	6.72
70	1.129	1.211	1.299	-6.77	6.77
71	1.095	1.175	1.261	-6.81	6.82
72	1.061	1.140	1.224	-6.93	6.86
73	1.029	1.106	1.188	-6.96	6.90
74	0.9977	1.073	1.153	-7.02	6.94
75	0.9676	1.041	1.120	-7.05	7.05
76	0.9385	1.011	1.088	-7.17	7.08
77	0.9104	0.9810	1.056	-7.20	7.10
78	0.8833	0.9523	1.026	-7.25	7.18

16. SENSOR PARAMETER

T [°C]	Rmin [KΩ]	Rnom [KΩ]	Rmax [KΩ]	DR(MIN)%	DR(MAX)%
79	0.8570	0.9246	0.9971	-7.31	7.27
80	0.8316	0.8977	0.9687	-7.36	7.33
81	0.8071	0.8717	0.9412	-7.41	7.38
82	0.7834	0.8466	0.9146	-7.47	7.43
83	0.7604	0.8223	0.8888	-7.53	7.48
84	0.7382	0.7987	0.8639	-7.57	7.55
85	0.7167	0.7759	0.8397	-7.63	7.60
86	0.6958	0.7537	0.8161	-7.68	7.65
87	0.6755	0.7322	0.7933	-7.74	7.70
88	0.6560	0.7114	0.7712	-7.79	7.75
89	0.6371	0.6913	0.7498	-7.84	7.80
90	0.6188	0.6718	0.7291	-7.89	7.86
91	0.6011	0.6530	0.7051	-7.95	7.39
92	0.5840	0.6348	0.6897	-8.00	7.96
93	0.5674	0.6171	0.6709	-8.05	8.02
94	0.5514	0.6000	0.6527	-8.10	8.07
95	0.5359	0.5835	0.6350	-8.16	8.11
96	0.5209	0.5675	0.6179	-8.21	8.16
97	0.5064	0.5519	0.6014	-8.24	8.23
98	0.4923	0.5369	0.5853	-8.31	8.27
99	0.4787	0.5224	0.5698	-8.37	8.32
100	0.4655	0.5083	0.5547	-8.42	8.36
101	0.4528	0.4946	0.5401	-8.45	8.42
102	0.4404	0.4814	0.5259	-8.52	8.46
103	0.4284	0.4685	0.5121	-8.56	8.51
104	0.4168	0.4561	0.4988	-8.62	8.56
105	0.4056	0.4440	0.4859	-8.65	8.62
106	0.3947	0.4323	0.4733	-8.70	8.66
107	0.3841	0.4210	0.4611	-8.76	8.70
108	0.3739	0.4100	0.4493	-8.80	8.75
109	0.3640	0.3993	0.4379	-8.84	8.81
110	0.3544	0.3890	0.4267	-8.89	8.84
111	0.3450	0.3789	0.4159	-8.95	8.90
112	0.3360	0.3692	0.4055	-8.99	8.95
113	0.3272	0.3597	0.3953	-9.04	9.01
114	0.3187	0.3505	0.3854	-9.07	9.06
115	0.3104	0.3416	0.3758	-9.13	9.10
116	0.3024	0.3330	0.3665	-9.19	9.14
117	0.2947	0.3246	0.3574	-9.21	9.18
118	0.2871	0.3164	0.3468	-9.26	8.77
119	0.2798	0.3085	0.3401	-9.30	9.29
120	0.2727	0.3008	0.33	-9.34	9.34

17.TROUBLESHOOTING

17. Troubleshooting

17.1 Trouble guide

Troubleshooting for normal malfunction

Troubleshooting	Possible Reasons for Abnormality	How to Deal With
Air conditioner can not start up	<ol style="list-style-type: none"> 1. Power supply failure; 2. Trip of breaker or blow of fuse; 3. Power voltage is too low; 4. Improper setting of remote controller ; 5. Remote controller is short of power. 	<ol style="list-style-type: none"> 1. Check power supply circuit; 2. Measure insulation resistance to ground to see if there is any leakage; 3. Check if there is a defective contact or leak current in the power supply circuit; 4. Check and set remote controller again; 5. Change batteries.
The compressor starts or stops frequently	The air inlet and outlet has been blocked.	Remove block obstacles.
Poor cooling/heating	<ol style="list-style-type: none"> 1. The outdoor heat exchanger is dirty, such as condenser; 2. There are heating devices indoors; 3. The air tightness is not enough. People come in and out too frequently. 4. Block of outdoor heat exchanger; 5. Improper setting of temperature. 	<ol style="list-style-type: none"> 1. Clean the heat exchanger of the outdoor unit, such as condenser ; 2. Remove heating devices; 3. Keep certain air tightness indoors; 4. Remove block obstacles; 5. Check and try to set temperature again.
Sound from deforming parts	During system starting or stopping, a sound might be heard. However, this is due to thermal deformation of plastic parts.	It is not abnormal, and the sound will disappear soon.
Water leakage	<ol style="list-style-type: none"> 1. Drainage pipe is blocked or broken; 2. Wrap of refrigerant pipe joint is not closed completely. 	<ol style="list-style-type: none"> 1. Change drainage pipe. 2. Re-wrap and make it tight.

Troubleshooting according to fault codes

When the air conditioner failure occurs, the fault code will display on control board, wired controller or display panel.

How to check fault codes

Indoor Unit

(1) Fault codes indicated by wired controller

MODEL:YXC-C01U/YXE-C01U/YXC-D01U/YXE-D01U(E)

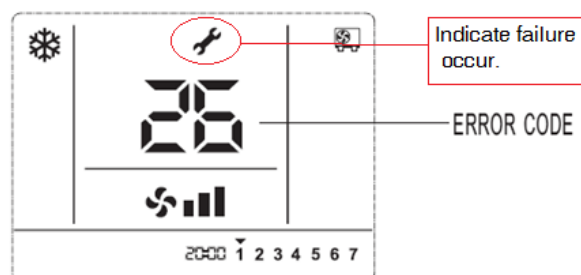

When the airconditioner is malfunction, will display on the LCD, and error codes will appear and blink.

FIG1. FAULT CODE DISPLAY ON WIRE REMOT CONTROLLER

17. TROUBLESHOOTING

(2) Fault codes indicated by LED lamps on display panel

Lamp RUN (LED2, Red) and Lamp DEFROST (LED5, Green) flash. Lamp RUN displays fault code represented by 2- digit number, lamp DEFROST displays fault code represented by single digit number (as shown fig. below). For example, fault code 36: LED RUN & defrost flash 3 times at the same time, and LED DEFROST continue flashing 3 times, reports No. 36 fault.

Display panel

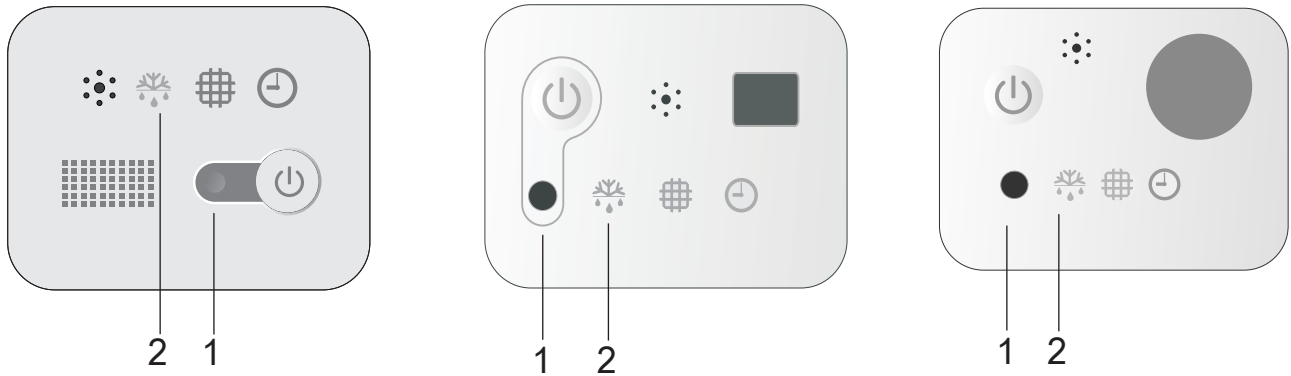

- 1** Run indicator (Red)
Indicates the fault code represented by 2-digit number.
- 2** Defrost indicator (Green)
Indicates the fault code represented by single digit number.

LED FLASH CONTROL flash 300ms (T1) off 300ms(T2), after 2000ms (T3) fault code repeat displays. (as shown below)

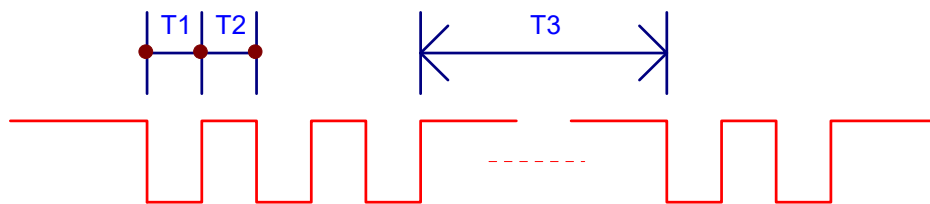

FIG.2 LED flash control

17.TROUBLESHOOTING

Outdoorunit

9K/12K/18K

DC-Inverterunitary (Maincontrolboardupside-down)

Fault code displayed by LED lamps on outdoor main control board.

There are 3 LED lamps on control board, LED1, LED2 and LED3.

LED1 indicates fault code represented by 2-digit number, LED2 indicates fault code represented by single digit number and LED3 indicates outdoor drive control fault.

When LED3 is off, LED1 and LED 2 indicate main control fault code.

When LED3 is on, LED1 and LED 2 indicate drive control fault code.

When LED3 is flickering and LED1, LED 2 are all off, indicate compressor is preheating. Failures display with 5s interval. It means LED will be off for 5s to report the next fault code.

System protection codes display method is the same with main control fault code.

LED lamps will be off when there is no failure, protection or preheating.

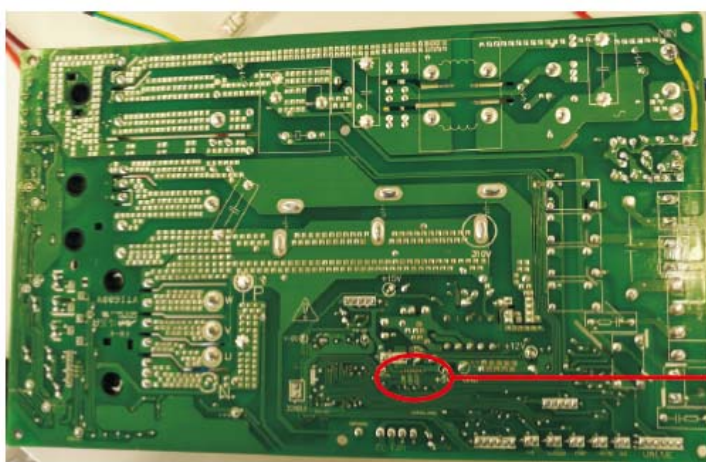

For example, outdoor main control fault 32:

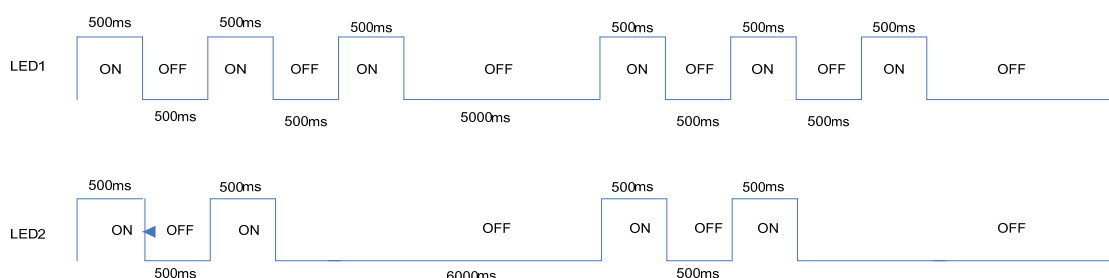

For example, outdoor drive fault 32:

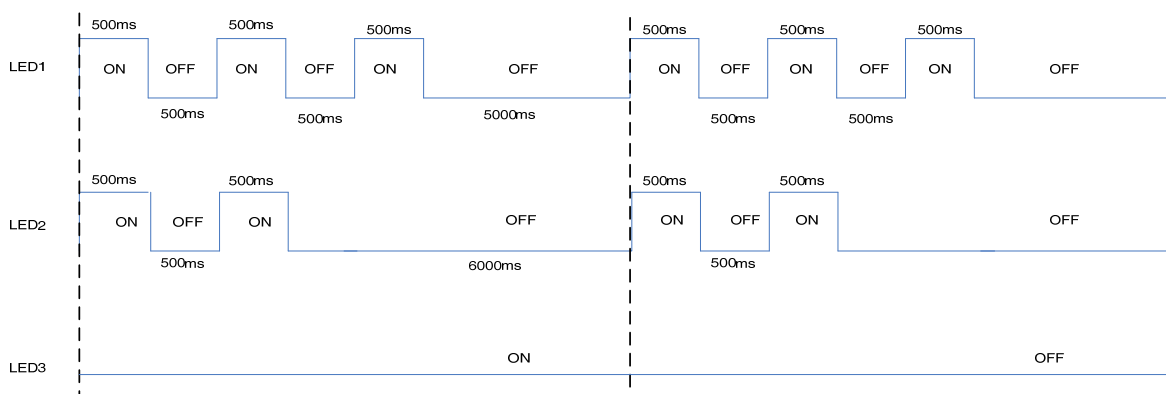

17.TROUBLESHOOTING

24K/36K

Main control fault display

Fault code will be displayed on digital tube board.

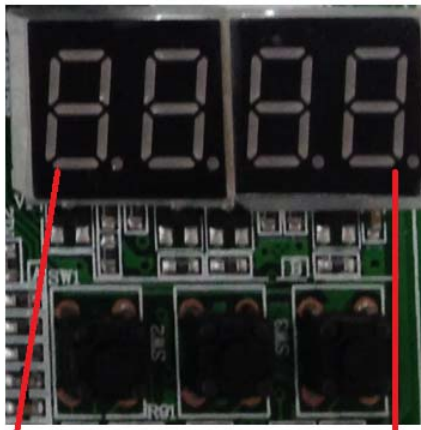
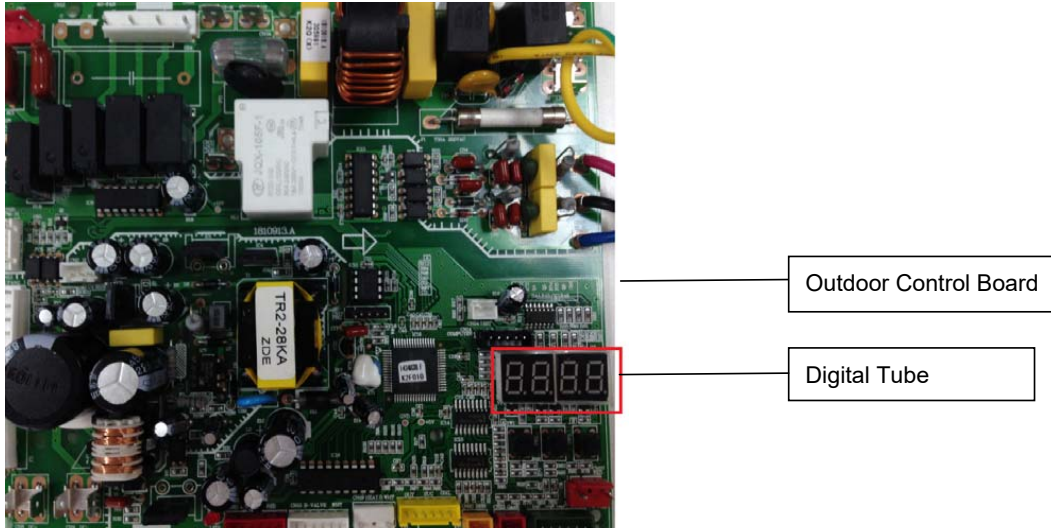

E shows failure occur

Display ERROR Code

Drive fault code display

The lamp of drive board flashing shows failure occurs.

17.TROUBLESHOOTING

Drive fault code display

The lamp of drive board flashing shows failure occurs.

How many times the drive failure lamp flicks will show the failure code.

Single phase models:

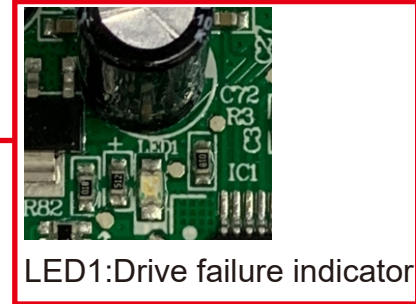
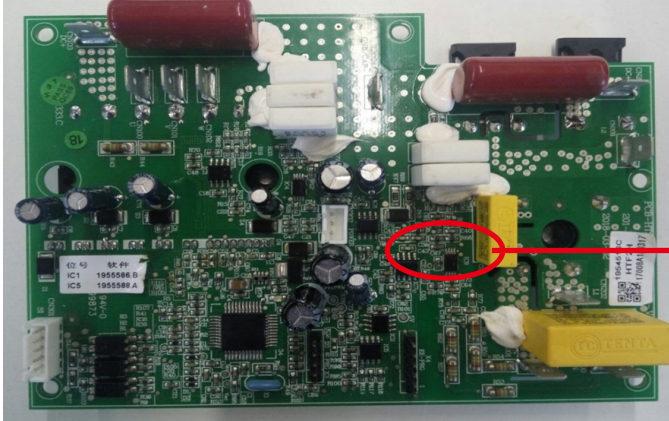

LED1: Drive failure indicator

17. TROUBLESHOOTING

17.2 Fault codes

The following is the fault code table of outdoor units.

Table 1 Outdoor fault code

Fault code	Fault description	Possible reasons for abnormality	How to deal with	Remarks
1	Outdoor ambient temperature sensor fault	<ol style="list-style-type: none"> 1.The outdoor ambient temperature sensor is connected loosely; 2.The outdoor ambient temperature sensor fails to work; 3.The sampling circuit fails. 	<ol style="list-style-type: none"> 1.Reconnect the outdoor ambient temperature sensor; 2.Replace the outdoor ambient temperature sensor components; 3.Replace the outdoor control board components. 	
2	Outdoor coil temperature sensor fault	<ol style="list-style-type: none"> 1.The outdoor coil temperature sensor is connected loosely; 2.The outdoor coil temperature sensor fails to work; 3.The sampling circuit fails. 	<ol style="list-style-type: none"> 1.Reconnect the outdoor coil temperature sensor; 2.Replace the outdoor coil temperature sensor components; 3.Replace the outdoor control board components. 	
3	The unit over-current turn off fault	<ol style="list-style-type: none"> 1. Control board current sampling circuit fails; 2. The current is over high because the supply voltage is too low; 3. The compressor is blocked; 4. Overload in cooling mode; 5. Overload in heating mode. 	<ol style="list-style-type: none"> 1. Replace the electrical control board components; 2. Normal protection; 3. Replace the compressor; 4. Please see NOTE 3; 5. Please see NOTE 4. 	
4	EEprom Data error	<ol style="list-style-type: none"> 1.EE components fails; 2.EE components control circuit fails; 3.EE components are inserted incorrectly. 	<ol style="list-style-type: none"> 1.Replace the EE components; 2.Replace the outdoor control board components; 3.Reassemble the EE components. 	
5	Cooling freezing protection (the indoor coil temperature is too low) or heating overload (indoor coil temperature is too high)	<ol style="list-style-type: none"> 1.The indoor unit can not blow air normally; 2.The room temperature is too low in cooling mode or the room temperature is too high in heating; 3.The filter is dirty; 4.The duct resistance is too high to result in low air flow; 5.The setting fan speed is too low; 6.The indoor unit is not installed in accordance with the installation standards, and the air inlet is too close to the air outlet . 	<ol style="list-style-type: none"> 1.Check whether the indoor fan, indoor fan motor and evaporator work normally; 2.Normal protection; 3.Clean the filter; 4.Check the volume control valve, duct length etc.; 5.Set the speed with high speed; 6.Reinstall the indoor unit referring to the user manual to change the distance between the indoor unit and the wall or ceiling. 	
7	The communication fault between the indoor unit and outdoor unit	<ol style="list-style-type: none"> 1.The connection cable is connected improperly between the indoor unit and outdoor unit; 2.The communication cable is connected loosely; 3.The communication cable fails; 4.The indoor control board fails; 5.The outdoor control board fails; 6.Communication circuit fuse open; 7.The specification of communication cable is incorrect. 	<ol style="list-style-type: none"> 1.Reconnect the connection cable referring to the wiring diagram; 2.Reconnect the communication cable; 3.Replace the communication cable; 4.Replace the indoor control board; 5.Replace the outdoor control board; 6.Check the communication circuit, adjust the DIP switch and the short-circuit fuse. 7.Choose suitable communication cable referring to the user manual 	

17. TROUBLESHOOTING

Fault code	Fault description	Possible reasons for abnormality	How to deal with	Remarks
13	Compressor overheat protector device	<ol style="list-style-type: none"> 1. The wiring of the overload protector is connected loosely. 2. The overload protector fails . 3. The refrigerant is not enough; 4. The installation pipe is much longer than the normal one, but extra refrigerant is not added ; 5. The expansion valve fails; 6. The outdoor control board fails. 	<ol style="list-style-type: none"> 1. Reconnect the wiring of the overload protector; 2. Replace the overload protector; 3. Check the welding point of the unit to confirm whether it is leakage, and then recharge the refrigerant; 4. Add the refrigerant; 5. Replace expansion valve; 6. Replace the outdoor control board. 	
14	The high pressure switch operation or the unit is turned off for high pressure protection	<ol style="list-style-type: none"> 1.The wiring of the high pressure protector is connected loosely; 2.The high pressure protector fails; 3.The outdoor control board is abnormal; 4. Overload in cooling; 5. Overload in heating. 	<ol style="list-style-type: none"> 1. Reconnect the wiring of the high pressure protector; 2. Replace the high pressure protector; 3. Replace the outdoor control board; 4. Please refer to NOTE 3; 5. Please refer to NOTE 4. 	Applied to models with high pressure switch or pressure sensor
15	The low pressure switch protection or the unit is turned off for low pressure protection	<ol style="list-style-type: none"> 1. The wiring of the low pressure switch is connected loosely; 2. The low pressure switch fails; 3. The refrigerant is not enough; 4. The expansion valve fails in heating mode; 5. The outdoor control board is abnormal. 	<ol style="list-style-type: none"> 1. Reconnect the wiring of the low pressure switch; 2. Replace the low pressure switch; 3. Check the welding point to confirm whether the unit leaks, and add some refrigerant; 4. Replace the expansion valve; 5. Replace the outdoor control board. 	Applied to models with low pressure switch or pressure sensor
16	Overload protection in cooling mode	System overload	Please refer to NOTE 3.	
17	Discharge temperature sensor fault	<ol style="list-style-type: none"> 1.The wiring of the discharge temperature sensor is connected loosely; 2. The discharge temperature sensor fails; 3.The sampling circuit is abnormal. 	<ol style="list-style-type: none"> 1. Reconnect the wiring of the discharge temperature sensor; 2. Replace the discharge temperature sensor; 3. Replace the outdoor control board. 	
18	AC voltage is abnormal	<ol style="list-style-type: none"> 1.The AC voltage>275V or <160V; 2.The AC voltage of sampling circuit on the driver board is abnormal. 	<ol style="list-style-type: none"> 1. Normal protection, please check the supply power; 2. Replace the driver board. 	
19	Suction temperature sensor fault	<ol style="list-style-type: none"> 1.The wiring of the suction temperature sensor is connected loosely; 2.The suction temperature sensor fails; 3.The sampling circuit is abnormal. 	<ol style="list-style-type: none"> 1.Reconnect the wiring of the suction temperature sensor; 2.Replace the suction temperature sensor; 3.Replace the outdoor control board. 	
22	The defrosting sensor fault	<ol style="list-style-type: none"> 1.The wiring of the defrosting sensor is connected loosely; 2.The defrosting sensor fails; 3.The sampling circuit is abnormal. 	<ol style="list-style-type: none"> 1. Reconnect the wiring of the defrosting sensor; 2. Replace the defrosting sensor; 3. Replace the outdoor control board. 	
45	IPM fault	There are many reasons for this failure. You can check the driver board fault LED to further analyze the fault code of the drive board and to learn about what leads to the fault and how to operate it. Specific information can be seen in table 5, table 6.	See attached "analysis of the driving board fault".	

17. TROUBLESHOOTING

Fault code	Fault description	Possible reasons for abnormality	How to deal with	Remarks
46	IPM and control board communication fault	<ol style="list-style-type: none"> 1.The cable between the control board and the driver board is connected loosely; 2.The cable between the control board and the driver board fails; 3.The driver board fails ; 4.The control board fails. 	<ol style="list-style-type: none"> 1.Reconnect the cable between the control board and the driver board; 2.Replace the communication cable between the control board and the driver board; 3.Replace the driver board; 4.Replace the control board. 	
47	Too high discharge temperature fault	<ol style="list-style-type: none"> 1. The refrigerant of the unit is not enough; 2.The refrigerant of the unit is not enough due to that the installation pipe is longer. 3.Throttling service fails; 4.The outdoor ambient temperature is too high. 	<ol style="list-style-type: none"> 1.Check the welding point to confirm whether the unit has leakage point, and add some refrigerant; 2.Add some refrigerant referring to the installation user manual; 3.Replace the throttling service (such as capillary, expansion valve); 4.Normally protection. 	
48	The outdoor DC fan motor fault (upper fan motor)	<ol style="list-style-type: none"> 1.The connecting wiring of the up DC fan motor is loose; 2.The cord of the upper DC fan motor fails; 3.The upper DC fan motor fails; 4.The drive circuit of the upper DC fan motor fails; 5.The outdoor fan has been blocked. 	<ol style="list-style-type: none"> 1.Reconnect the wiring of the up DC fan motor; 2.Replace the upper DC fan motor; 3.Replace the upper DC fan motor; 4.Replace the driver board of the fan motor; 5.Check the outdoor fan and ensure the outdoor fan can run normally. 	
49	The outdoor DC fan motor fault (down fan motor)	<ol style="list-style-type: none"> 1.The connecting wiring of the down DC fan motor is loose; 2.The cord of the down DC fan motor fails; 3. The down DC fan motor fails; 4. The drive circuit of the down DC fan motor fails; 5. The outdoor fan has been blocked. 	<ol style="list-style-type: none"> 1. Reconnect the wiring of the down DC fan motor; 2. Replace the down DC fan motor; 3. Replace the down DC fan motor; 4. Replace the driver board of the fan motor; 5. Check the outdoor fan and ensure the outdoor fan can run normally. 	
91	The unit turn off due to the IPM board over heating fault	<ol style="list-style-type: none"> 1.The outdoor ambient temp. is too high; 2. The speed of the out fan motor is too low if the fan motor is AC fan motor; 3.The outdoor unit is not installed in accordance with the standard; 4.The supply power is too low. 	<ol style="list-style-type: none"> 1. Normal protection; 2. Check the fan capacitor, and replace the fan capacitor if it is failure; 3. Reinstalled the outdoor unit refer to the installation user manual; 4. Normal protection. 	
96	Lacking of refrigerant	The refrigerant of the unit is not enough.	Discharge the refrigerant and charge the refrigerant referring to the rating label.	
97	4-way valve commutation failure fault	<ol style="list-style-type: none"> 1.The connecting wiring of the 4-way valve coil is loose; 2.The 4-way valve coil fails; 3.The 4-way valve fails; 4.The driver board of the 4-way valve fails. 	<ol style="list-style-type: none"> 1. Reconnect the wiring of the 4-way valve; 2. Replace the 4-way valve coil; 3. Replace the 4-way valve; 4.Replace the driver board of the 4-way valve. 	

17. TROUBLESHOOTING

The following is the fault code table of indoor unit.

Table 2 Indoor fault code

Fault code	Fault description	Possible reasons for abnormality	How to deal with	Remarks
51	Drainage protection	<ol style="list-style-type: none"> 1. The water level of the drain pan exceed safe level; 2. The cable of the water level switch is connected loosely; 3. The water level switch fails; 4. The control board fails. 	<ol style="list-style-type: none"> 1.1 Check whether there is something blocking the drain hose or the height of the drain hose is too high; 1.2 Check the water pump and replace the water pump if the water pump fails; 2. Reconnect the cable of the water level switch referring to the wiring diagram; 3. Replace the water level switch; 4. Replace the control board. 	
55	Mode conflict fault	The user set the conflicting mode for more than two indoor units.	Reset the operation mode for the indoor unit, for with one outdoor unit, the user should avoid setting the conflicting operation mode with the indoor units.	
64	Communication between Indoor & Outdoor unit Fault	<ol style="list-style-type: none"> 1. The indoor unit and the outdoor unit are not connected properly; 2. The communication cable is connected loosely; 3. The communication cable between the indoor unit and the outdoor unit is failure or the cable between the indoor control board to terminal fails or the cable between the outdoor control board to the terminal fails; 4. The indoor control board fails; 5. The outdoor control board fails. 	<ol style="list-style-type: none"> 1. Reconnect the connection cable referring to the indoor and outdoor wiring diagram; 2. Reconnect the communication cable referring to the indoor and outdoor wiring diagram; 3. Replace the communication cable referring to the indoor and outdoor wiring diagram; 4. Replace the indoor control board; 5. Replace the outdoor control board. 	
71	Indoor unit zero check fault	<ol style="list-style-type: none"> 1. The motor wire is loosen; 2. The motor connection is open; 3. The motor fails; 4. Control board fails. 5. Indoor fan is baffled. 	<ol style="list-style-type: none"> 1. Replace the motor wire and make sure the wire connect is well; 2. Replace the motor wire; 3. Change the motor; 4. Change the indoor control board; 5. Check and elimination of fan motor rotation. 	
72	Indoor fan motor fault	<ol style="list-style-type: none"> 1. The cable of the indoor fan motor is connected loosely; 2. The cable of the indoor fan motor fails; 3. The indoor fan motor fails; 4. The indoor control board fails. 	<ol style="list-style-type: none"> 1. Reconnect the cable of the fan motor; 2. Replace the cable of the fan motor; 3. Replace the fan motor; 4. Replace the indoor control board; 5. Check the indoor fan and ensure the indoor fan can run normally. 	
73	Indoor EEPROM Data 1 fault	<ol style="list-style-type: none"> 1. Indoor EE components fails; 2. The control circuit of the EE components fails; 3. The EE components has been inserted in opposite direction. 	<ol style="list-style-type: none"> 1. Replace the EE components; 2. Replace the indoor control board; 3. Reassembly the EE components of the indoor control board. 	

17. TROUBLESHOOTING

Fault code	Fault description	Possible reasons for abnormality	How to deal with	Remarks
74	Indoor EEPROM Data 2 fault	EE in MCU fails, the unit can run, but the function user has set is ineffective.	Replace EE data in MCU.	
81	Indoor ambient Temperature Sensor Fault	<ol style="list-style-type: none"> 1. The cable of the room temperature sensor is connected loosely; 2. The room temperature sensor fails; 3. The sampling circuit is abnormal. 	<ol style="list-style-type: none"> 1. Reconnect the cable of the room temperature sensor; 2. Replace the room temperature sensor; 3. Replace the indoor control board. 	
83	Evaporator Middle Temperature Sensor Fault	<ol style="list-style-type: none"> 1. The cable of the coil temperature sensor of the evaporator fails; 2. The coil temperature sensor of the evaporator fails; 3. The sampling circuit is abnormal. 	<ol style="list-style-type: none"> 1. Reconnect the cable of the coil temperature sensor of the evaporator; 2. Replace the coil temperature sensor of the evaporator; 3. Replace the indoor control board. 	
FE (254)	Communication between main control board & Wired controller Fault (display on wired controller)	<ol style="list-style-type: none"> 1. The wired controller and the indoor control board are connected loosely. 2. The sequence of the wiring between the wired controller to the indoor control board is wrong; 3. The wiring between the wired controller to the indoor control board fails; 4. The wired controller is fails; 5. The indoor control board is abnormal. 	<ol style="list-style-type: none"> 1. Reconnect the wiring between the wired controller to the indoor control board; 2. Replace the wiring between the wired controller to the indoor control board; 3. Replace the wiring between the wired controller to the indoor control board; 4. Replace the wired controller; 5. Replace the indoor control board. 	
ER	Communication between main control board & display board Fault (displays on display board)	<ol style="list-style-type: none"> 1. The wiring between the display board to the indoor control board is connected loosely; 2. The sequence of the wiring between the display board to the indoor control board is wrong; 3. The wiring between the display board to the indoor control board fails; 4. The display board fails; 5. The indoor control board fails. 	<ol style="list-style-type: none"> 1. Reconnect the wiring between the display board to the indoor control board; 2. Replace the wiring between the display board to the indoor control board; 3. Replace the wiring between the display board to the indoor control board; 4. Replace the display board; 5. Replace the indoor control board. 	

17. TROUBLESHOOTING

NOTE 1:

If the indoor unit can not start or the indoor unit stops itself after 30s, at the same time the unit do not display the fault code, please check the fire and the socket of the control board.

NOTE 2:

If the indoor unit displays the 75,76,77,78 fault code after you turn on the unit, please check the TEST seat of the indoor control board or the TEST detection circuit to see whether short circuit occurs.

NOTE 3: Overload in cooling mode

Overload in cooling mode		
sr.	The root cause	Corrective measure
1	The refrigerant is excessive.	Discharge the refrigerant, and recharge the refrigerant referring to the rating label.
2	The outdoor ambient temperature is too high.	Please use it within allowable temperature range
3	Short-circuit occurs in the air outlet and air inlet of the outdoor unit.	Adjust the installation of the outdoor unit referring to the user manual.
4	The outdoor heat exchanger is dirty, such as condenser.	Clean the heat exchanger of the outdoor unit, such as condenser.
5	The speed of the outdoor fan motor is too low.	Check the outdoor fan motor and fan capacitor.
6	The outdoor fan is broken or the outdoor fan is blocked.	Check the outdoor fan.
7	The air inlet and outlet has been blocked.	Remove the blocked objects.
8	The expansion valve or the capillary fails.	Replace the expansion valve or the capillary.

NOTE 4: Over load in heating mode

Overload in heating mode		
sr.	The root cause	Corrective measure
1	The refrigerant is excessive.	Discharge the refrigerant, and recharge the refrigerant referring to the rating label.
2	The indoor ambient temperature is too high.	Please use within allowable temperature range.
3	Short-circuit occurs in the air outlet and air inlet of the indoor unit.	Adjust the installation of the indoor unit referring to the user manual.
4	The indoor filter is dirty.	Clean the indoor filter.
5	The speed of the indoor fan motor is too low.	Check the indoor fan motor and fan capacitor.
6	The indoor fan is broken or the outdoor fan is blocked.	Check the indoor fan.
7	The air inlet and outlet has been blocked.	Remove the blocked objects.
8	The expansion valve or the capillary fails.	Replace the expansion valve or the capillary.

17. TROUBLESHOOTING

Table 3 Drive fault code (3.0/3.5HP)

Fault code	Fault description	Possible reasons for abnormality	How to deal with
1	Inverter DC voltage overload fault	1. Power supply input is too high or too low; 2. Driver board fault.	1. Check power supply ; 2. Change driver board.
2	Inverter DC low voltage fault		
3	Inverter AC current overload fault		
4	Out-of-step detection		
5	Loss phase detection fault (speed pulsation)	1. Compressor phase lost ; 2. Bad driver board components ; 3. The compressor insulation fault.	1. Check compressor wire connection; 2. Change the driver board; 3. Change compressor.
6	Loss phase detection fault (current imbalance)		
7	Inverter IPM fault (edge)	1. System overload or current overload; 2. Driver board fault. 3. Compressor oil shortage, serious wear of crankshaft ; 4. The compressor insulation fault.	1. Check the system. 2. Change the driver board; 3. Change the compressor; 4. Change the compressor.
8	Inverter IPM fault (level)		
9	PFC_IPM IPM fault (edge)		
10	PFC_IPM IPM fault (level)		
11	PFC power detection of failure	1. The power supply is not stable; 2. Instantaneous power off; 3. Driver board failure.	1. Check the power supply. 2. No need to deal with. 3. Change the driver board.
12	PFC overload current detection of failure.	1. System overload, current is too high; 2. Driver board fails; 3. PFC fails.	1. Check the system; 2. Change the driver board; 3. Change the PFC.
13	DC voltage detected abnormal .	1. Input voltage is too high or too low; 2. Driver board fails.	1. Check the power supply; 2. Change the driver board.
14	PFC LOW voltage detected failure.		
15	AD offset abnormal detected failure.	Driver board fails.	Change the driver board.
16	Inverter PWM logic set fault.		
17	Inverter PWM initialization failure		
18	PFC_PWM logic set fault.		
19	PFC_PWM initialization fault.		
20	Temperature abnormal.		
21	Shunt resistance unbalance adjustment fault		
22	Communication failure.	1. Communication wire connection is not proper; 2. Driver board fails; 3. Control board fails.	1. Check the wiring; 2. Change the driver board; 3. Change the control board.
23	Motor parameters setting of failure	Initialization is abnormal.	Reset the power supply.
25	EE data abnormal	Driver board EEPROM is abnormal	1. Change EEPROM ; 2. Change the driver board.
26	DC voltage mutation error	1. Power input changes suddenly 2. Driver board fails.	1. Check power supply, to provide stable power supply; 2. Change driver board.
27	D axis current control error	1. System overload, phase current is too high; 2. Driver board fails.	1. Check system to see if it works normally. 2. Check stop valve to see if it is open; 3. Change the driver board.
28	Q axis current control error	1. System overloads, phase current is too high ; 2. Driver board fails.	1. Check system to see if it works normally. 2. Check stop valve to see if it is open; 3. Change the driver board.
29	Saturation error of d axis current control integral	1. System overload suddenly; 2. Compressor parameter is not suitable; 3. Driver board fails.	1. Check system to see if it works normally. 2. Check stop valve to see if it is open; 3. Change the driver board.
30	Saturation error of q axis current control integral	1. System overload suddenly; 2. Compressor parameter is not suitable; 3. Driver board fails.	1. Check system to see if it works normally. 2. Check stop valve to see if it is open; 3. Change the driver board.

17. TROUBLESHOOTING

Table 4 Drive Fault Code (24K/36K)

Fault code	Fault description	Possible reasons for abnormality	How to deal with
1	Q axis current detection, failure in drive control	1. Compressor wire is not connected properly; 2. Bad driver board components; 3. Compressor start load is too large; 4. Compressor demagnetization; 5. The compressor is short of oil, and the crankshaft is worn seriously; 6. The compressor insulation fails.	1. Check the compressor wire; 2. Change the driver board ; 3. Turn on the unit after the pressure is balanced again; 4. Change the compressor; 5. Change the compressor; 6. Change the compressor.
2	Phase current detection, failure in drive control	1.Compressor voltage default phase; 2.Bad driver board components; 3.The compressor insulation fault.	1.Check the compressor wire connection; 2.Change the driver board; 3.Change the Compressor.
3	Initialization, phase current imbalance	Bad driver board components.	Change the driver board .
4	Speed estimation, failure in drive control	1.Bad driver board components; 2.Compressor shaft is clamped; 3.The compressor insulation fails.	1.Change the driver board ; 2.Change the Compressor ; 3.Change the Compressor .
5	IPM FO output fault	1. System overload or current overloads. 2. Driver board fails; 3. The compressor is short of oil, and the crankshaft is worn seriously; 4. The compressor insulation fault.	1.Check the air conditioner system; 2.Change the driver board; 3.Change the Compressor; 4.Change the Compressor.
6	Communication between driver board and control board fault	1.Communication wire connection is not well; 2.Driver board fault; 3.Control board fault.	1. Check the compressor wire connect. 2. Change the driver board; 3. Change the control board ;
7	AC voltage, overload voltage	1. Supply voltage input is too high or too low; 2. Driver board fails;	1.Check the power supply; 2.Change the driver board;
8	DC voltage, overload voltage	1. Supply voltage input is too high ; 2. Driver board fault;	1. Check the power supply; 2. Change the driver board;
9	AC voltage imbalance	Driver board fails;	Change the driver board;
10	The PFC current detection circuit fault before compressor is ON	Bad driver board components.	Change the driver board.
11	AC voltage supply in outrange	1.Power supply is abnormal, power frequency is out of range; 2.Driver board fails;	1. Check the system; 2. Change the driver board;
12	Products of single-phase PFC over-current, FO output at low level	1. System overload, current is too large; 2. Driver board fault; 3. PFC fault.	1. Check the system; 2. Change the driver board; 3. Change PFC.
	Inverter over current (3-phase power supply air conditioners)	1. System overload, current is too large; 2. Driver board fault; 3. The compressor is short of oil, and the crankshaft is worn seriously; 4. The compressor insulation fault.	1. Check the system; 2. Change the driver board; 3. Change the Compressor; 4. Change the Compressor.
13	Inverter over current	1. System overload, current is too large; 2. Driver board fault; 3. The compressor is short of oil, and the crankshaft is worn seriously; 4. The compressor insulation fault.	1. Check the system; 2. Change the driver board; 3. Change the Compressor; 4. Change the Compressor.
14	PFC over current(single phase air-conditioner)	1. System overload, current is too large; 2. Driver board fault; 3. PFC fault.	1. Check the system; 2. Change the driver board; 3. Change PFC.
	Phase imbalance or phase lacks or the instantaneous power failure (only for 3-phase power supply air conditioners)	1.3-Phase voltage imbalance; 2.The 3-phase power supply phase lost; 3.Power supply wiring is wrong; 4.Driver board fault.	1, Check the power supply; 2. Check the power supply; 3. Check the power supply wiring connect; 4.Change the driver board.
15	The instantaneous power off detection	1.The power supply is not stable ; 2.The instantaneous power failure ; 3.Driver board fault.	1. Check the power supply; 2. Not fault; 3. Change the driver board.

17. TROUBLESHOOTING

Fault code	Fault description	Possible reasons for abnormality	How to deal with
16	Low DC voltage 200V	1. Voltage input is too low; 2. Drive board fault.	1. Check the power supply; 2. Change the driver board.
18	Driver board read EE data error	1. EEPROM has no data or data error; 2. EEPROM circuit fault.	1. Change EEPROM component; 2. Change the driver board.
19	PFC chip receive data fault	Abnormal communication loop.	Change the drive board.
20	PFC soft start abnormally	Abnormal PFC drive loop.	Change the drive board.
21	The compressor drive chip could not receive data from PFC chip.	Communication loop fault.	Change the drive board.

18. CHECKING COMPONENTS

18. Checking components

18.1 Check refrigerant system

TEST SYSTEM FLOW

Conditions: ① Compressor is running.

② The air condition should be installed in good ventilation.

Tool: Pressure Gauge

Technique: ① see ② feel ③ test

See ----- Tube defrost.

Feel ----- The difference between tube's temperature.

Test ----- Test pressure.

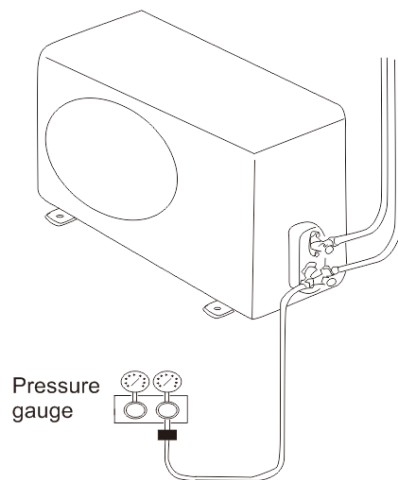

18. CHECKING COMPONENTS

Test system flow

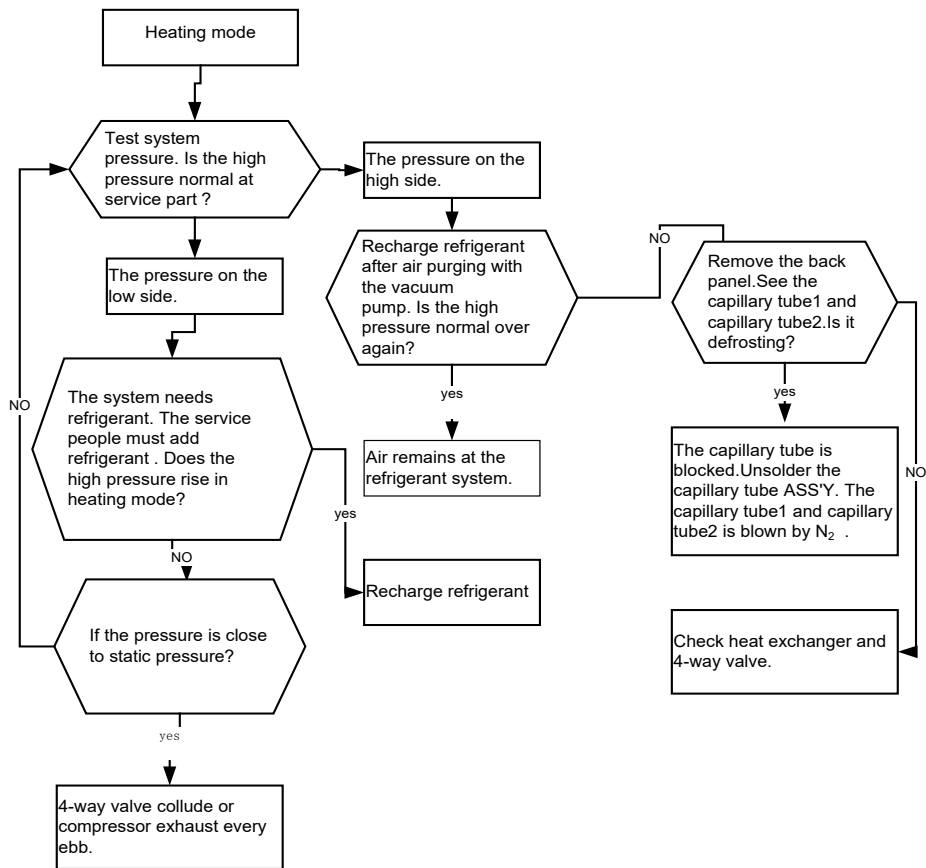
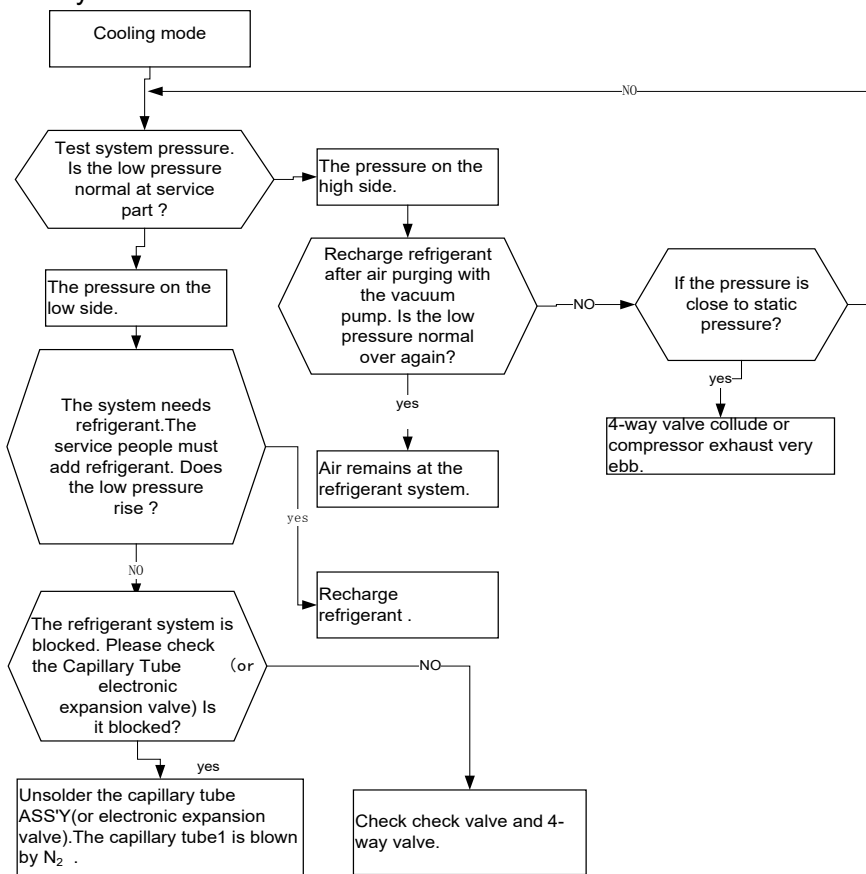

18. CHECKING COMPONENTS

18.2 Check parts unit

1. Indoor unit fan motor

Duct motor model (DC motor)

9K/12K/18K: SIC-68CVL-F160-2

Cassette motor model (DC motor)

9K/12K: SIC-62FW-D857-15

18K/24K: EHDS50AQH

36K: SIC-72FW-D8124-2B

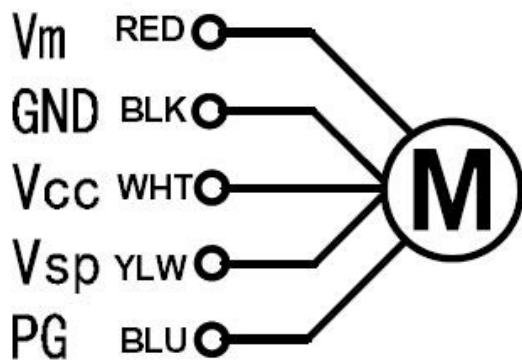

Test in resistance.

TOOL: Multimeter.

Test the resistance of the main winding. The indoor fan motor fails if the resistance of main winding is 0 (short circuit) or ∞ (open circuit).

Test in voltage

TOOL: Multimeter.

Insert screwdriver to rotate indoor fan motor slowly for 1 revolution or over, and measure voltage "YELLOW" and "GND" on motor. The voltage repeat 0V DC and 5V DC.

Notes:

Please don't hold motor by lead wires.

Please don't plug IN/OUT the motor connector while power is ON.

Please don't drop or dump motor against hard material. Malfunction may not be observed at early stage after such shock. But it may be found later, this type of mishandling void our warranty.

18. CHECKING COMPONENTS

2. Outdoor unit fan motor

DC motor

9K: SIC-52FV-F130-3

12K: SIC-62FV-D857-15

18K: ZWK511A805001

24K: SIC-71FW-D8121-1

36K: SIC-81FW-F1138-1

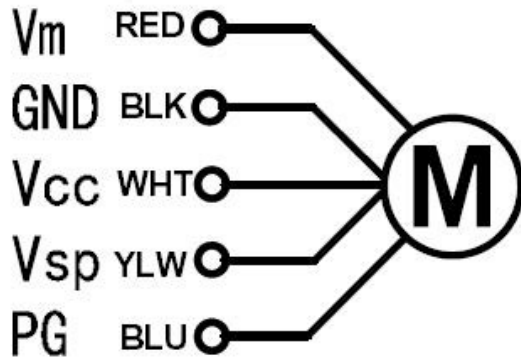

3. Compressor

Compressor examine and repair

9K/12K: ASN108D43UFZA

18K: ATM150D23UFZ

24K: EATF250D22UMT

36K: ATF310D43UMT

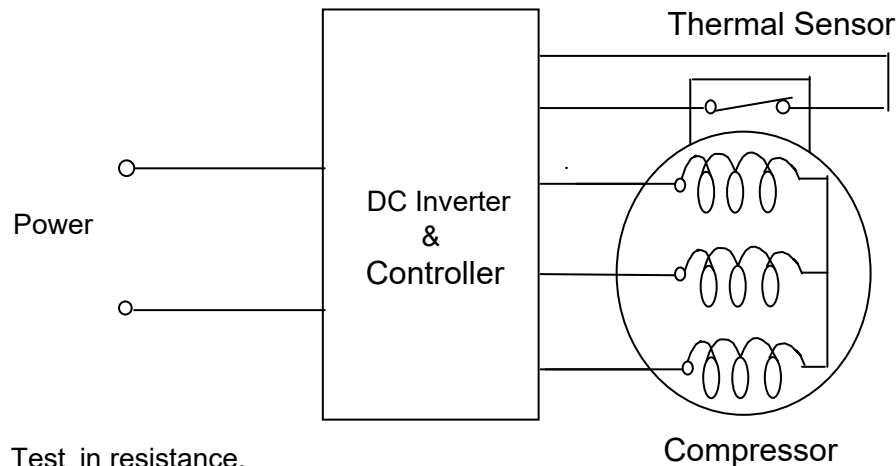

Test in resistance.

TOOL: Multi-meter.

Test the resistance of the winding. The compressor fails if the resistance of winding is 0 (short circuit) or ∞ (open circuit).

Familiar error:

- 1) Compressor motor lock.
- 2) Discharge pressure value approaches static pressure value.
- 3) Compressor motor winding abnormality.

18. CHECKING COMPONENTS

Notes:

- 1) Don't put a compressor on its side or turn over.
- 2) Please assemble the compressor in your air conditioner rapidly after removing the plugs.
Don't place the comp. in air for a long time.
- 3) Avoid compressor running in reverse caused by connecting electrical wire incorrectly.
- 4) Warning! In case AC voltage is impressed to compressor, the compressor performance will decrease because of its rotor magnetic force decreasing.

3. Inductance

Familiar error:

- 1) Sound abnormality
- 2) Insulation resistance disqualification

5. Step motor

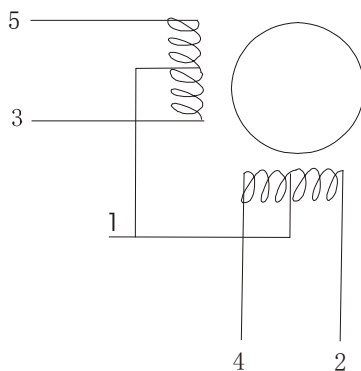

Test in resistance.

TOOL: Multimeter.

Test the resistance of winding. The stepper motor fails if the resistance of winding is 0 (short circuit) or ∞ (open circuit) .

6. Fuse

Check for continuity of fuse on PCB ASS'Y.

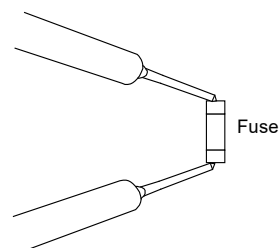
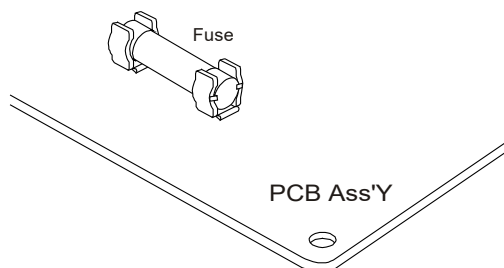

Remove the PCB ASS'Y from the electrical component box. Then pull out the fuse from the PCB ASS'Y. Check for continuity by a multimeter as shown below.



19. DISASSEMBLY AND ASSEMBLY FOR COMPRESSOR AND MOTOR

19. Disassembly and assembly for compressor and motor

The special tools for compressor & motor disassembly and assembly:

	Tool
1	Hexagon Screwdriver 
2	Hexagon Socket 

Outdoor unit 9K/12K/18K

Important: Before disassembly and assembly, make sure that the power to the system has been disconnected and verified as voltage free.

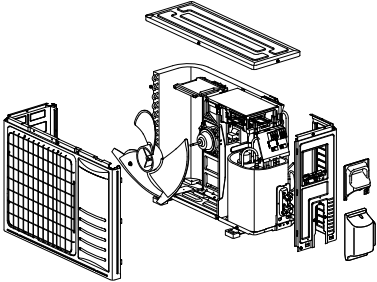
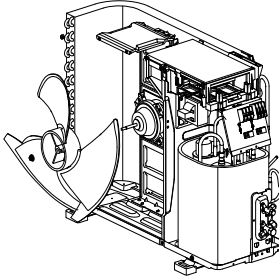
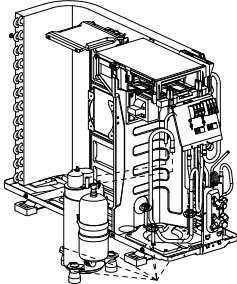
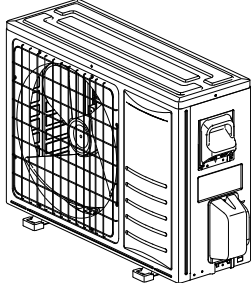
Step	Illustration	Handling Instruction
1. Remove external casing		<ol style="list-style-type: none"> 1. Remove the top cover, handle and valve cover; 2. Remove the outer case and right side plate.
2. Remove motor		<ol style="list-style-type: none"> 1. Remove the blade nut and then remove the blade; 2. Remove the motor from motor supporter.
3. Remove compressor		<ol style="list-style-type: none"> 1. Reclaim the refrigerant from the entire system; 2. Unsolder the 4-way valve piping assy from compressor; 3. Remove the compressor mounting bolts; 4. Carefully remove the compressor from chassis.
4. Assemble unit		Assemble the unit in the reverse order of disassembly.

19. DISASSEMBLY AND ASSEMBLY FOR COMPRESSOR AND MOTOR

24K

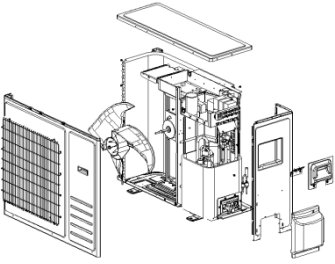
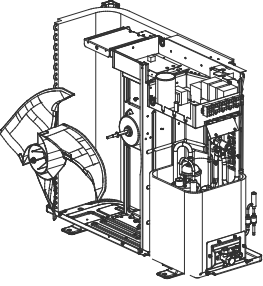
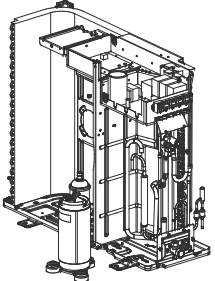
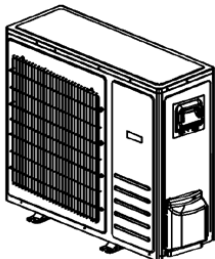
Important: Before disassembly and assembly, make sure that the power to the system has been disconnected and verified as voltage free.		
Step	Illustration	Handling Instruction
1. Remove external casing		<ol style="list-style-type: none"> 1. Remove the top cover, handle and valve cover; 2. Remove the outer case and right side plate.
2. Remove motor		<ol style="list-style-type: none"> 1. Remove the blade nut and then remove the blade; 2. Remove the motor from motor supporter.
3. Remove compressor		<ol style="list-style-type: none"> 1. Reclaim the refrigerant from the entire system; 2. Unsolder the 4-way valve piping assy from compressor; 3. Remove the compressor mounting bolts; 4. Carefully remove the compressor from chassis.
4. Assemble unit		<p>Assemble the unit in the reverse order of disassembly.</p>

19. DISASSEMBLY AND ASSEMBLY FOR COMPRESSOR AND MOTOR

36K

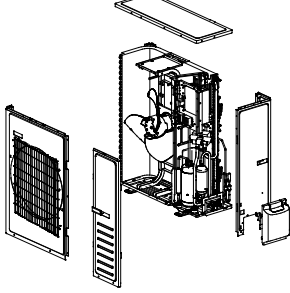
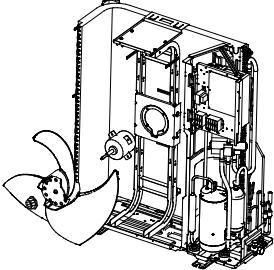
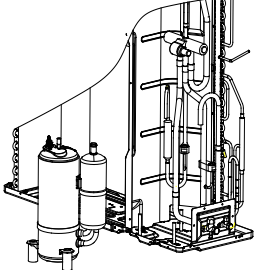
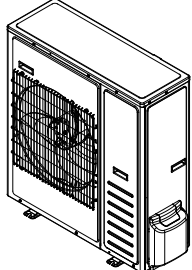
Important: Before disassembly and assembly, make sure that the power to the system has been disconnected and verified as voltage free.		
Step	Illustration	Handling Instruction
1. Remove external casing		<ol style="list-style-type: none"> 1. Remove the top cover, handle and valve cover; 2. Remove the outer case and right side plate.
2. Remove motor		<ol style="list-style-type: none"> 1. Remove the blade nut and then remove the blade; 2. Remove the motor from motor supporter.
3. Remove compressor		<ol style="list-style-type: none"> 1. Reclaim the refrigerant from the entire system; 2. Unsolder the 4-way valve piping assy from compressor; 3. Remove the compressor mounting bolts; 4. Carefully remove the compressor from chassis.
4. Assemble unit		<p>Assemble the unit in the reverse order of disassembly.</p>

19. DISASSEMBLY AND ASSEMBLY FOR COMPRESSOR AND MOTOR

Duct type
9K/12K

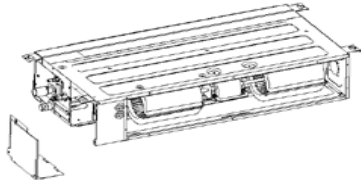
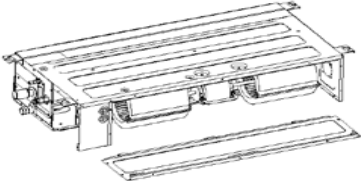
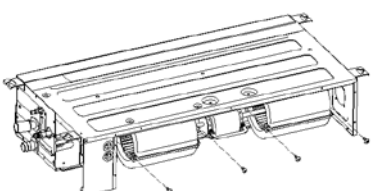
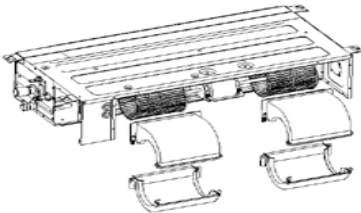
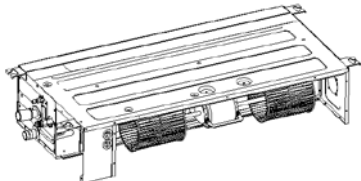
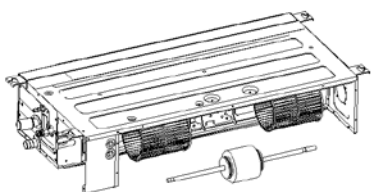
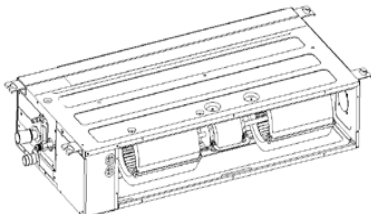
Removal and Assembly of Fan Motor		
Important: Before removing the fan, make sure power to the system is disconnected.		
Step	Illustration	Handling Instruction
1. Unplug the motor cables.		Use screwdriver to remove the electric box cover and unplug the motor cables in electric box.
2. Remove the base board.		Loosen and take out the screws fixing the base board, then remove the base board.
3. Remove the screws on fan sub-assembly.		Remove the screws on fan sub-assembly.
4. Removing the fan cage enclosure.		Rotate the fan cage housing toward supply opening and remove.
5. Loosen the fan and motor.		Use a hex wrench to loosen the screws holding the fan cage to the motor shaft. Remove outer housing holding motor in place.
6. Replace the motor.		Remove the motor from the support bracket. Then remove the fan cages from the motor shafts. Remove the motor from the air inlet and replace with new motor. Be sure to tighten the cages onto the motor shafts.
7. Reassembly of the unit.		Reassemble the unit in the reverse order of disassembly and test operation.

19. DISASSEMBLY AND ASSEMBLY FOR COMPRESSOR AND MOTOR

Duct type

18K

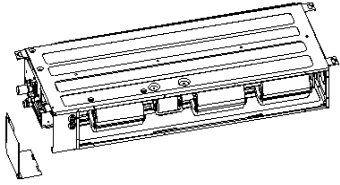
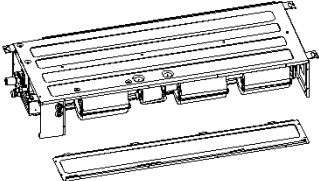
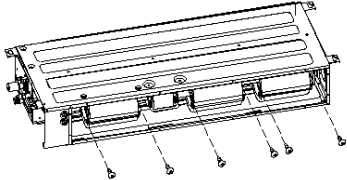
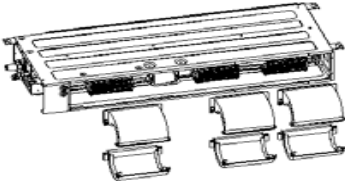
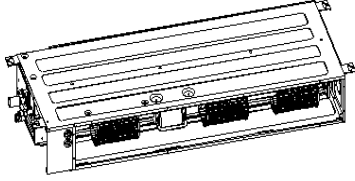
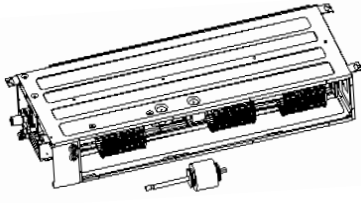
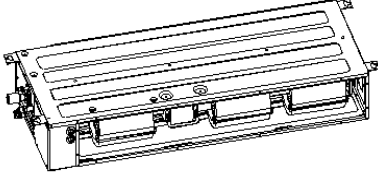
Removal and Assembly of Fan Motor		
Important: Before removing the fan, make sure power to the system is disconnected.		
Step	Illustration	Handling Instruction
1. Unplug the motor cables		Use screwdriver to remove the electric box cover and unplug the motor cables in electric box.
2. Remove the base board		Loosen and take out the screws fixing the base board, then remove the base board.
3. Remove the screws on fan sub-assembly.		Remove the screws on fan sub-assembly.
4. Removing the fan cage enclosure		Rotate the fan cage housing toward supply opening and remove.
5. Loosen the fan, crosshead and motor.		Use a hex wrench to loosen the screws holding the fan cage to the motor shaft, and the screws holding the crosshead to the motor shaft. Remove outer housing holding motor in place.
6. Replace the motor		Remove the motor from the support bracket. Then remove the fan cages from the motor shafts. Remove the motor from the air inlet and replace with new motor. Be sure to tighten the cages onto the motor shafts.
7. Reassembly of the unit		Reassemble the unit in the reverse order of disassembly and test operation.

19. DISASSEMBLY AND ASSEMBLY FOR COMPRESSOR AND MOTOR

Duct type 24K

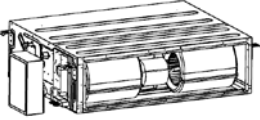
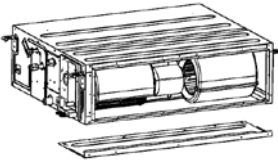
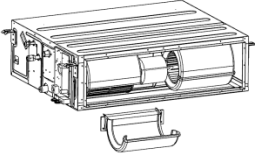
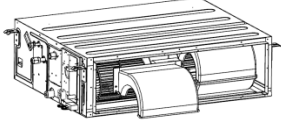
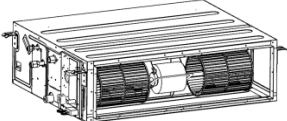
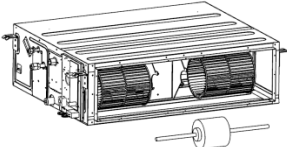
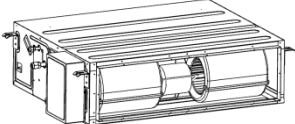
Removal and Assembly of Fan Motor		
Important: Before removing the fan, make sure power to the system is disconnected.		
Step	Illustration	Handling Instruction
1. Unplug the motor cables		Use screwdriver to remove the electric box cover and unplug the motor cables in electric box.
2. Remove the base board		Loosen and take out the screws fixing the base board, then remove the base board.
3. Remove the screws on fan sub-assembly.		Remove the screws on fan sub-assembly.
4. Removing the fan cage enclosure		Rotate the fan cage housing toward supply opening and remove.
5. Loosen the fan and motor.		Use a hex wrench to loosen the screws holding the fan cage to the motor shaft. Remove outer housing holding motor in place.
6. Replace the motor		Remove the motor from the support bracket. Then remove the fan cages from the motor shafts. Remove the motor from the air inlet and replace with new motor. Be sure to tighten the cages onto the motor shafts.
7. Reassembly of the unit		Reassemble the unit in the reverse order of disassembly and test operation.

19. DISASSEMBLY AND ASSEMBLY FOR COMPRESSOR AND MOTOR

Duct type 36K

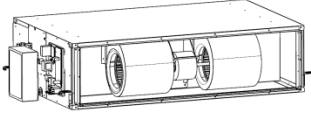
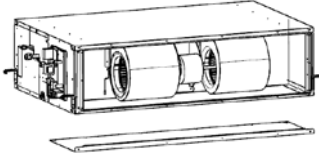
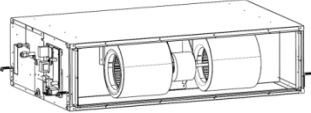
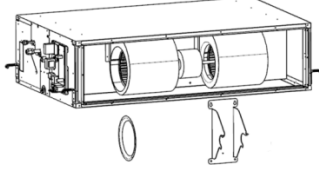
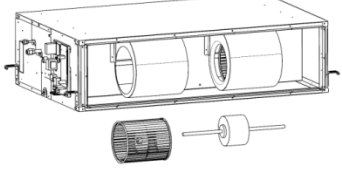
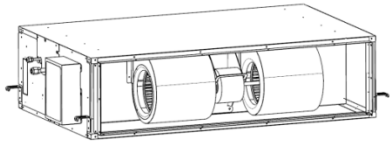
Removal and Assembly of Fan Motor		
Important: Before removing the fan, make sure power to the system is disconnected.		
Step	Illustration	Handling Instruction
1. Unplug the motor cables		Use screwdriver to remove the electric box cover and unplug the motor cables in electric box.
2. Remove the base board		Loosen and take out the screws fixing the base board, then remove the base board.
3. Loosen the fan and motor.		Use an offset spanner to loosen the screws holding the fan cage to the motor shaft. Remove outer housing holding motor in place.
4. Remove the diversion circle and support bracket.		Use screwdriver to remove the diversion circle and support bracket.
5. Replace the motor		Remove the fan cage from the motor shaft. Remove the motor from the air inlet and replace with new motor. Be sure to tighten the cages onto the motor shafts.
6. Reassembly of the unit		Reassemble the unit in the reverse order of disassembly and test operation.

19. DISASSEMBLY AND ASSEMBLY FOR COMPRESSOR AND MOTOR

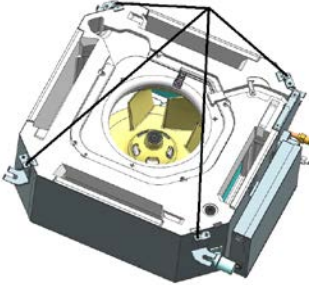
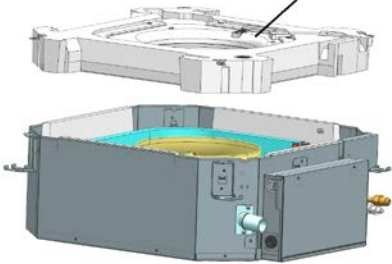
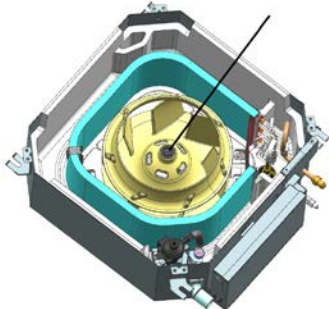
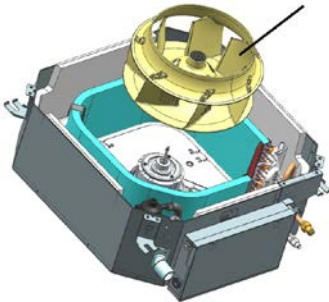
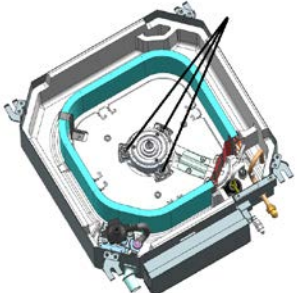

Cassette type
9K/12K/18K

Replacement of Fan Motor		
Step	Illustration	Handling Instruction
1. Loosen the screws holding condensate pan.		Use screwdriver to loosen the screws holding the drain pan in place.
2. Remove the condensate pan		Carefully remove the condensate pan.
3. Loosen the bolt holding the fan blade in place		Use a wrench or socket to carefully remove the fan blade bolt.
4. Remove the fan blade		The fan blade can now be removed.
5. Loosen the bolts holding the motor in place		Use a wrench or socket to carefully remove the motor bolts.

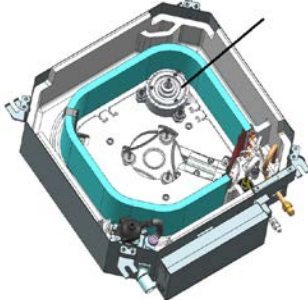
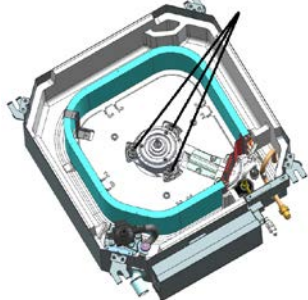
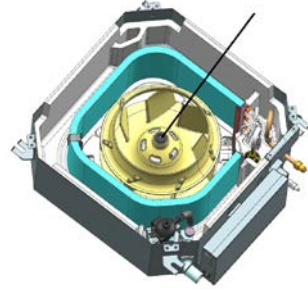
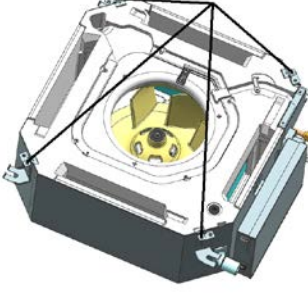
19. DISASSEMBLY AND ASSEMBLY FOR COMPRESSOR AND MOTOR

Replacement of Fan Motor		
Step	Illustration	Handling Instruction
6. Remove the motor and replace it		Remove the motor and replace it.
7. Tighten the bolts holding the motor		Use a wrench or socket to carefully tighten the motor bolts.
8. Mount the fan blade and tighten the bolt		Mount the fan blade and use a wrench or socket to carefully tighten the bolt holding the fan blade in place. Do not overtighten as damage may occur.
9. Reinstall the condensate pan and tighten the screws		Use a screwdriver to carefully tighten the screws holding the condensate pan in place. Take care not to not over-tighten as damage to pan will occur.

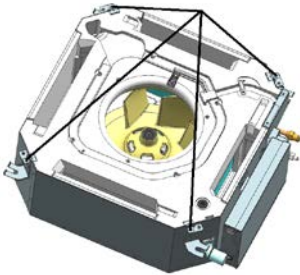
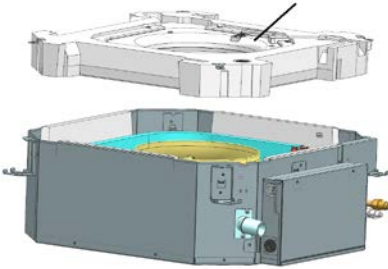
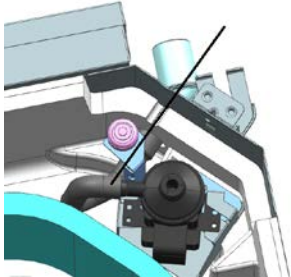
19. DISASSEMBLY AND ASSEMBLY FOR COMPRESSOR AND MOTOR

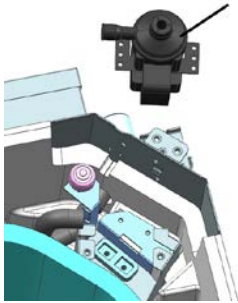
Removal and Installation of Condensate Pump		
Step	Illustration	Handling Instruction
1. Loosen the screws holding condensate pan.		Use screwdriver to loosen the screws holding the drain pan in place.
2. Remove the condensate pan.		Carefully remove the condensate pan.
3. Pull out the water outlet pipe.		Pull out the water outlet Pipe.
4. Loosen the screws holding the condensate pump.		Loosen the screws holding the condensate pump.
5. Take out the pump and replace it.		Take out the pump and replace it.

19. DISASSEMBLY AND ASSEMBLY FOR COMPRESSOR AND MOTOR

Cassette type
24K/36K

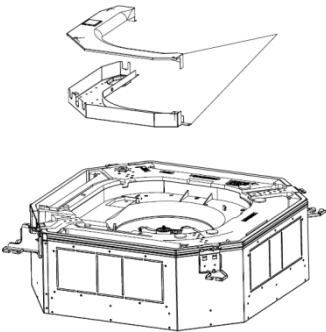
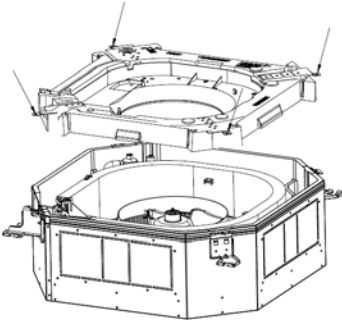
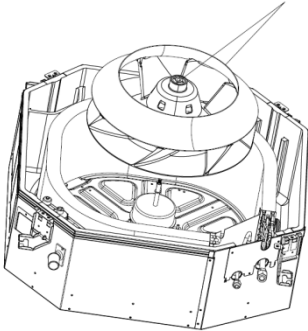
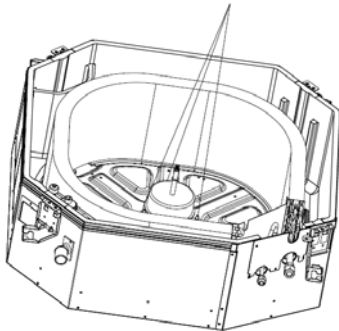
Step	Illustration	Handling Instruction
<p>1. Loosen the screws holding the electric box cover and electric box.</p>	 <p>The illustration shows two parts: a curved metal cover and a rectangular metal box. Below them is a perspective view of the unit with the cover and box removed, showing the internal components.</p>	<p>Use screwdriver to loosen the Electric box.</p>
<p>2. Loosen the screws holding condensate pan and Remove the condensate pan.</p>	 <p>The illustration shows the condensate pan being lifted out of the unit. Below it is a perspective view of the unit with the pan removed, showing the internal structure.</p>	<p>Use screwdriver to loosen the screws holding the drain pan in place.</p>
<p>3. Loosen the bolts holding the fan blades in place and Remove the fan blade.</p>	 <p>The illustration shows the fan blade being removed from the motor. Below it is a perspective view of the unit with the fan blade removed, showing the motor and other internal parts.</p>	<p>Use a wrench or socket to carefully remove the fan blade bolts.</p>
<p>4. Loosen the screws holding the motor in place and Remove the motor and replace it.</p>	 <p>The illustration shows the motor being removed from the unit. Below it is a perspective view of the unit with the motor removed, showing the internal structure.</p>	<p>Use screwdriver to loosen the screws holding the motor.</p>

20. CONTORL LOGIC DESCRIPTION

20. Control logic description

20.1 Fan Only Mode

- (1) Outdoor fan and compressor stop.
- (2) Temperature setting function is disabled, and no setting temperature is displayed.
- (3) Indoor fan can be set to high/medium/low, but can not be set to auto.

20.2 Cooling Mode

Indoor fan running rules:

In cooling mode, indoor fan runs all the time and the speed can be selected as high,(medium), low and auto.

The auto fan:

T1 is indoor room temperature. Ts is setting temperature.

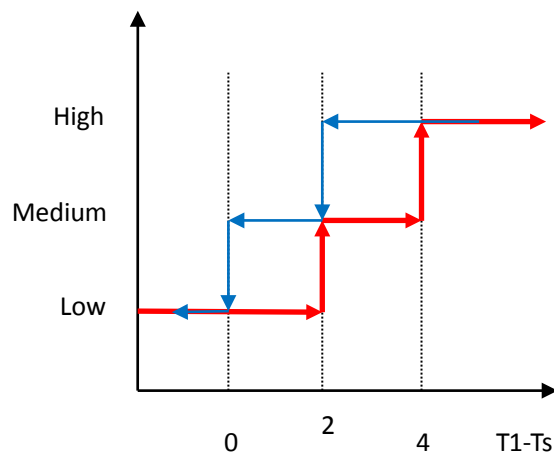

Inverter outdoor unit:

Compressor and outdoor fan running rules:

Once the compressor starts up, it will follow the below rules:

When indoor room temp. T1 is lower than Ts, the compressor and outdoor fan will shut off.

When T1 is higher than Ts+1, the compressor and outdoor fan will start up.

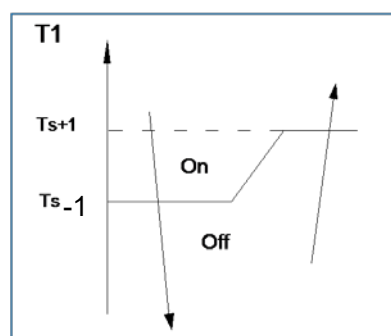

Outdoor fan running rules:

Once the outdoor fan start up, it will follow the below rules:

Single outdoor fan: First, it will run in an invariable speed for a short time; Then it will regulate the speed by the outdoor-coil temperature.

Double outdoor fan: If it has two outdoor fans, the upper fan regulates the speed by the rules, and the downer fan speed lower than the upper fan speed for 30rpm~60rpm.

20. CONTORL LOGIC DESCRIPTION

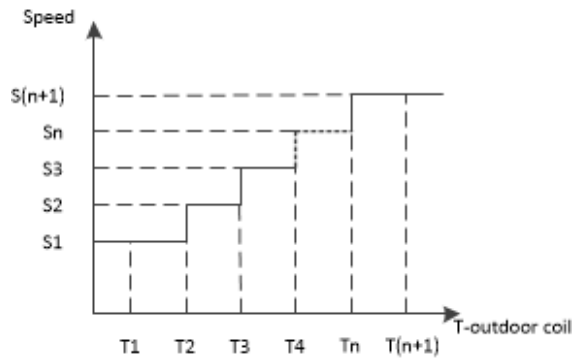

20.3 Heating Mode

Indoor fan running rules:

In several minutes after the heating mode is started, the fan of the indoor unit will not run until the heat exchanger of the indoor unit reaches a high enough temperature. That is because cold air prevention system is operating. After several minutes, the speed can be selected as high, (medium), low and auto.

The auto fan:

T_1 is indoor room temperature. T_s is setting temperature.

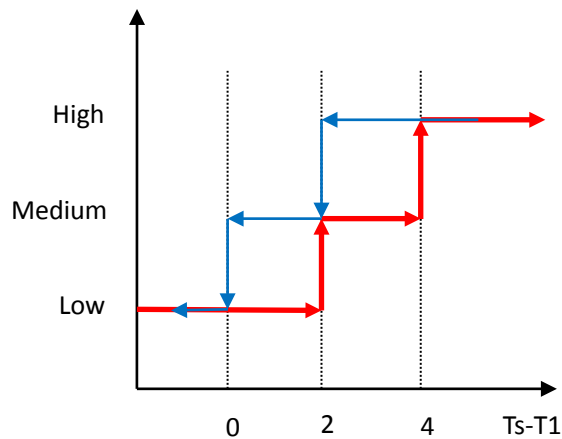

DC-Inverter outdoor unit:

Outdoor fan running rules:

Once the outdoor fan start up, it will follow the below rules:

Single outdoor fan: First, it will run in an invariable speed for a short time; Then it will regulate the speed by the indoor-coil temperature.

Double outdoor fan: If it has two outdoor fans, the upper fan regulates the speed by the rules, and the downer fan speed lower than the upper fan speed for 30rpm~60rpm.

20. CONTORL LOGIC DESCRIPTION

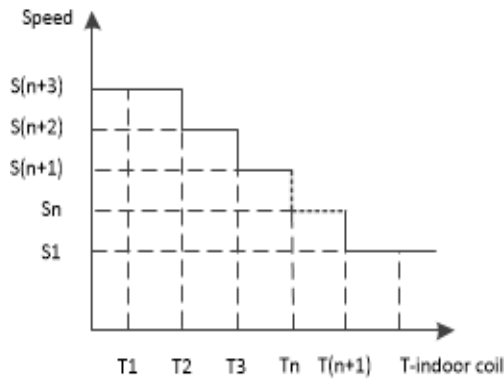

20.4 Auto Mode

This mode can be chosen with remote controller and the setting temperature can be changed between 61°F~86°F(16°C~30°C).

In auto mode, the unit will choose cooling, heating or fan-only mode according to ΔT ($\Delta T = T1 - Ts$).

$\Delta T = T1 - Ts$	Running mode
$\Delta T > 37^{\circ}\text{F}(3^{\circ}\text{C})$	Cooling
$27^{\circ}\text{F}(-3^{\circ}\text{C}) \leq \Delta T \leq 37^{\circ}\text{F}(3^{\circ}\text{C})$	Fan-only
$\Delta T < 27^{\circ}\text{F}(-3^{\circ}\text{C})$	Heating

Indoor fan will run at auto fan of the relevant mode. The louver operates same as in relevant mode. If the compressor keeps stopping for 10 minutes or the setting temperature is modified, the machine will choose mode according to ΔT again.

20.5 Evaporator Low-temperature Protection

DC-Inverter

AC will enter T2 protection if any of the following condition is satisfied.

Condition:

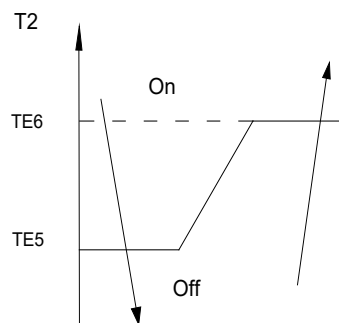

Cooling mode: When the indoor coil temp. T2 keeps lower than TE5 for 120 seconds, the compressor and outdoor fan will shut off. When T2 is higher than TE6, the compressor and outdoor fan will restart up.

20. CONTORL LOGIC DESCRIPTION

20.6 Condenser High-temperature Protection

DC-Inverter outdoor unit

AC will enter T3 protection if any of the following conditions is satisfied.

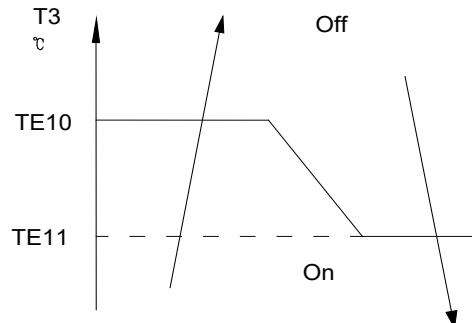

Condition1:

Cooling mode: When the outdoor coil temp. T3 keeps higher than T2 for 10 seconds, the compressor and outdoor fan will shut off. When T3 is lower than T1, the compressor and outdoor fan will restart up.

Condition2:

Heating mode: When the indoor coil temp. T3 keeps higher than T2 for 10 seconds, the compressor and outdoor fan will shut off. When T3 is lower than T1, the compressor and outdoor fan will restart up.

Hisense

Product improvement, specifications and appearance in this manual are subject to change without prior notice.