

Project Name:	
Location:	
Engineer:	
Submitted to:	
Submitted by:	
Reference:	

Approval:	
Date:	
Construction:	
Unit #:	
Drawing #:	

Description:
Hi-Uni, Single Zone, 24,000 BTU Cassette Type Heat Pump



Indoor Unit Model:
 ACT-24UR3SGB



Condensing Unit Model:
 A UW-24U3SA

KEY FEATURES

Indoor Unit Features

- ❑ Universal indoor unit for both single-zone and multi-zones
- ❑ Self diagnostic and error code display
- ❑ Quiet operation down to 38 dBA sound pressure level
- ❑ Vertical auto-swing function for efficient air distribution throughout the room
- ❑ Outside-air intake and branch duct run Knockouts
- ❑ Standard drain pump with 47.2" lift
- ❑ Accessible and Washable filter
- ❑ Multiple control options available:
- ❑ Control:
 - ❖ Remote controller included
 - ❖ ConnectLife smart device app for remote access (Separate module needed)
 - ❖ Optional wiring control

Condensing Unit Features

- ❑ Self diagnostic and error code display
- ❑ Standard with base pan heater and compressor heater belt
- ❑ Universal outdoor model connecting with different indoor models for saving SKU numbers.
- ❑ Compact cabinet design.
- ❑ Wide temperature range:
 - ❖ Cooling: 5°F ~ 118°F
 - ❖ Heating: -13°F ~ 75°F

REMOTE CONTROLLER

- 24h Real Timer;
- **47°F/8° Celsius mode**, this feature maintains the room temperature steadily at 8°C and prevents the room from freezing
- Display Dimmer to eliminate light at night
- **Built-in Thermostat**: Control the temperature from where the user is and not where the AC is

J1-72



Button Description	
Start/Stop	Start/Stop indoor unit
Cool	Set to Cooling mode
Heat	Set to Heating mode
Timer on/Timer off	Set the time to turn on or turn off
Temperature	Set the target temperature
Mode	Select the operation mode
Speed	Set the fan speed
Super	Start the strong cooling/heating mode
Dimmer	Turn off the light
8°C Heat	Maintains the room temperature steadily at 8°C
Hor	Set horizontal airflow direction
Mute	Quiet mode
Smart	Set the room temp automatically
Mute	Start the mute mode
Sleep	Start the sleep mode

WIRING CONTROLLER

- ❑ 24h Real Timer and **Weekly Timer** setting;
- ❑ **Difference between YXE-C01U1(E) and YXE-C02U1(E):**
 - ❖ **Signal receiver** of Remote Control – **only YXE-C01U1(E)**
 - ❖ **Central Controller** for Max. 16 units - **only YXE-C02U1(E)**
- ❑ **Sleep Mode:** Keeps pace with the body' s metabolism at night by moderately increasing the output temperature to eliminate the feeling of being cold at night. This feature also reduces power consumption

YXE-C01U1(E)
YXE-C02U1(E)



Button Description

- 1 **ON/OFF BUTTON**
The appliance will be started or stopped when this button is pressed.
- 2 **RUN INDICATOR**
Indicates that the appliance is on.
- 3 **MODE BUTTON**
Press this button to select the operation mode.
- 4 **FAN BUTTON**
Used to select fan speed in sequence high-auto-low-medium-high.
- 5 **SWING BUTTON (Invalid for some models)**
Used to stop or start adjustment louver swinging and set the desired airflow direction.
- 6 **TIMER/CLOCK BUTTON**
Used to set the current time or set timer ON/OFF.
- 7 **SLEEP BUTTON**
Used to set or cancel Sleep Mode operation.
- 8 **ENTER BUTTON**
Used to confirm settings.
- 9 **CANCEL BUTTON**
Used to cancel settings.
- 10 **ADD.FUNC. BUTTON (Invalid for some models)**
Used to set filter cleaning, hot water, fresh air, electric heater, etc.
- 11 **INCREASE SETTING BUTTON**
Used to raise the set temperature;
It raise the values when setting.
- 12 **DECREASE SETTING BUTTON**
Used to lower the set temperature;
It lower the values when setting.
- 13 **LIQUID CRYSTAL DISPLAY(LCD) SCREEN**
Used to display indicator screens.

Technical Spec.

Model	ACT-24UR3SAGB
Indoor unit model	ACT-24UR3SGB
Outdoor unit model	AUW-24U3SA

PERFORMANCE DATA

Power supply	Ph-V-Hz	208/230V,1Ph,60Hz
--------------	---------	-------------------

Cooling

Capacity	Btu/h	24000
Input	W	1920
Rated current	A	8.8
EER2	Btu/w	12.5
SEER2	Btu/w	18.5

Heating at 47

Capacity	Btu/h	26000
Input	W	2112.5
Rated current	A	3.607178285
COP2(47°F)	W/W	3.1
HSPF2	Btu/w	10
COP2(5°F)	W/W	2.2

Electrical

MINIMUM CIRCUIT AMPACITY	A	23
MAX. FUSE	A	35
Connection wiring		4*16 AWG

Compressor

Type		ROTARY
Brand		GMCC
Capacity	Btu/h	26085
Input	W	2080
Rated current(RLA)	A	16.1
Locked rotor Amp(LRA)	A	---
Thermal protector		---
Thermal protector position		---
Refrigerant oil/oil charge	ml	VG74 /670

SYSTEM DATA

Design pressure	PSIG	550/240
Refrigerant type	oz	R410A/91.7
Refrigerant precharge	ft	25
Additional charge per ft.	oz	1.23
Liquid side/ Gas side	mm(in)	Φ9.52/Φ15.9(3/8"/5/8")
Max. refrigerant pipe length	ft	164
Max. difference in level	ft.	98

Technical Spec.

INDOOR UNIT DATA

Indoor fan motor		
Model		EHDS50AQH
Type		DC
Input		80
RLA	A	0.4
LRA	A	---
Winding Resistance	Ω	---
Capacitor	uF	---
Speed(Hi/Mi/Lo)	r/min	600/480/390
Air flow & Noise level		
Indoor air flow (Hi/Lo)	CFM	647/530/400
Indoor noise level (Hi/Lo)	dB(A)	44/40/38

Indoor unit

Dimension(W*H*D)	inch	33-1/8×9-3/4×33-1/8
Packing (W*H*D)	inch	39-1/4 ×14-5/8 ×37-5/8
Net/Gross weight	lbs.	59.5/79.5

OUTDOOR UNIT DATA

Outdoor fan motor		
Model		SIC-71FW-D8121-1
Type		DC
Input		121
RLA	A	1
LRA	A	---
Winding Resistance	Ω	---
Capacitor	uF	---
Speed	r/min	830
Air flow & Noise level		
Outdoor air flow	CFM	2235
Outdoor noise level	dB(A)	55

Outdoor unit

Dimension(W*H*D)	inch	37-3/8×33-1/8×13-3/8
Packing (W*H*D)	inch	43-3/4×36-1/4×18-1/8
Net/Gross weight	lbs.	155.1/166.4

Operation temperature

Indoor(cooling/ heating)	Deg. F	62~90/32~86
Outdoor(cooling/heating)	Deg. F	5~118/ -13~75

DIMENSIONAL DRAWING
Ceiling Cassette

Unit: inch(mm)

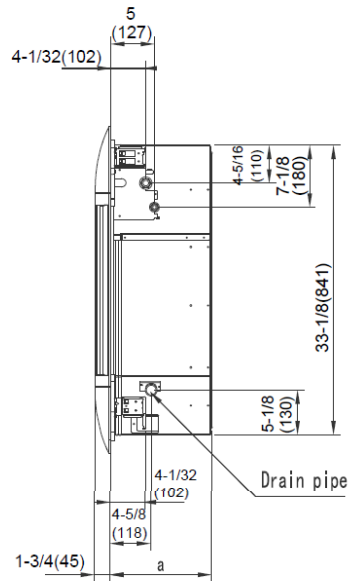
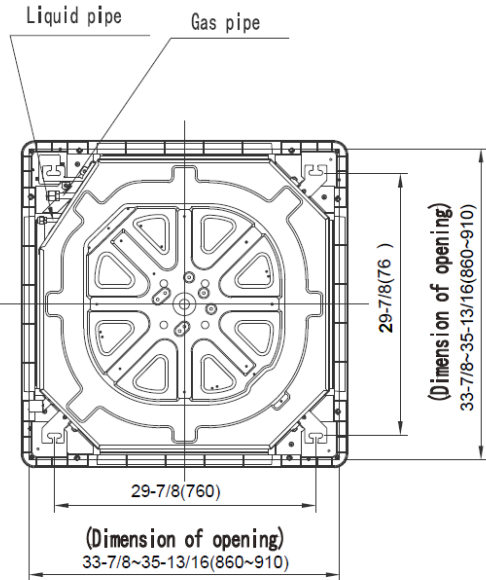
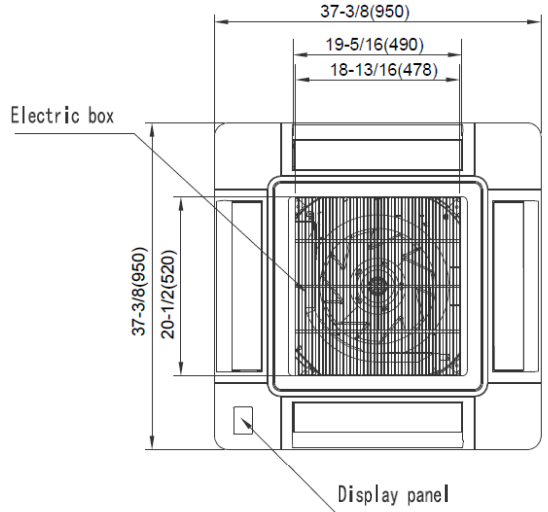
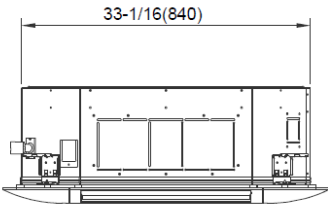

Model	a
18K/24K	9-3/4(248)
36K	11-3/4(298)

DIMENSIONAL DRAWING Condensing Units

Unit: inch(mm)

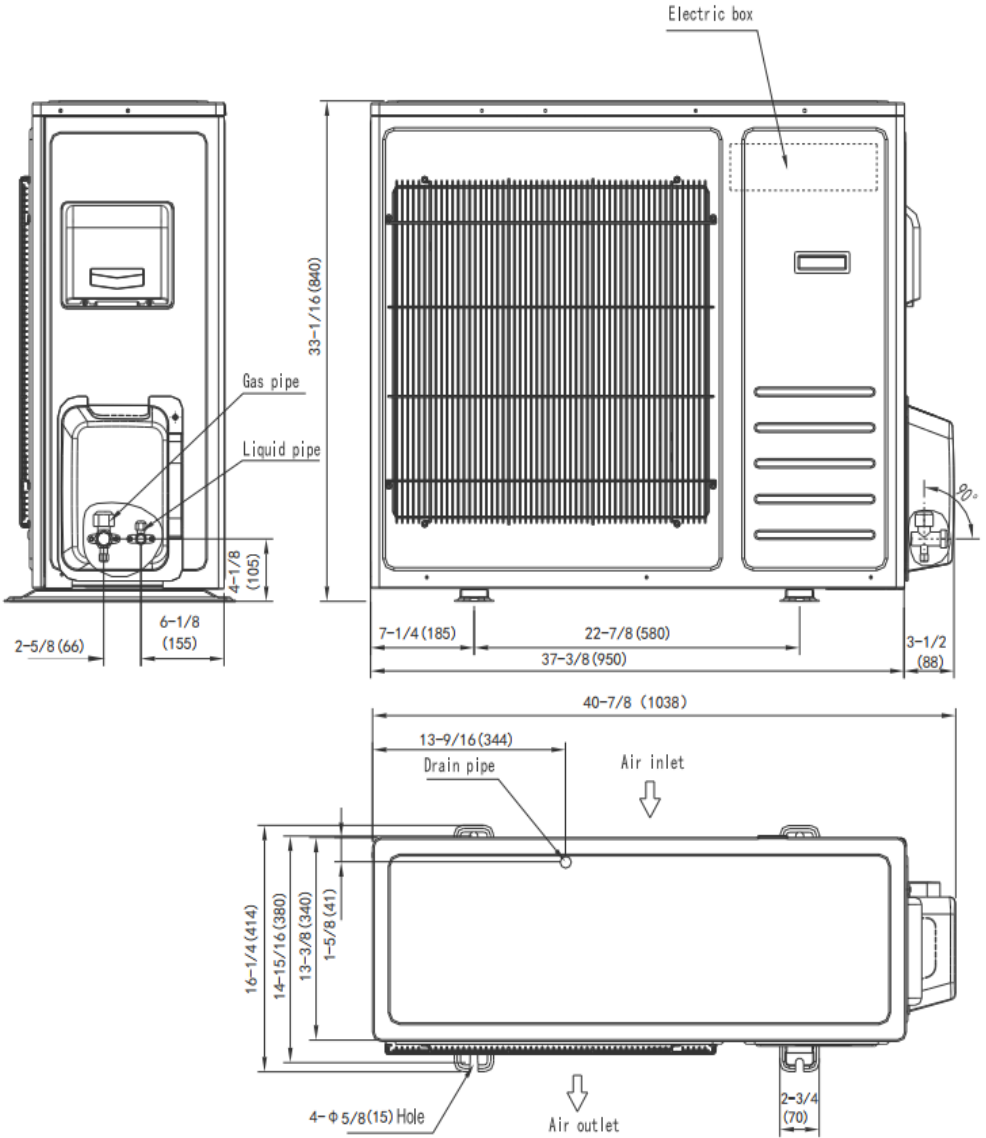

Project Name:	
Location:	
Engineer:	
Submitted to:	
Submitted by:	
Reference:	

Approval:	
Date:	
Construction:	
Unit #:	
Drawing #:	

Description:
Hi-Uni, Single Zone, 24,000 BTU Duct Type, Heat Pump



Indoor Unit Model:
 ADT-24UX3SLM



Condensing Unit Model:
 AUW-24U3SA

KEY FEATURES

Indoor Unit Features

- ❑ Universal indoor unit for both single-zone and multi-zones
- ❑ Self diagnostic and error code display
- ❑ Quiet operation down to 36 dBA sound pressure level
- ❑ Built-in drain pump with 47.2" lift
- ❑ Multiple control options available:
- ❑ Control:
 - ❖ Standard with Wired control YXE-C01U1(E)
 - ❖ Optional Remote controller
 - ❖ Connect Life smart device app for remote access (Separate module needed)

Condensing Unit Features

- ❑ Standard with base pan heater and compressor heater belt
- ❑ Self diagnostic and error code display
- ❑ Universal outdoor model connecting with different indoor models for saving SKU numbers
- ❑ High Pressure Ratio low-temperature compressor
- ❑ Compact cabinet design.
- ❑ Wide temperature range:
 - ❖ Cooling: 5°F ~ 118°F
 - ❖ Heating: -13°F ~ 75°F

REMOTE CONTROLLER

J1-72



- 24h Real Timer;
- **8° Celsius mode**, this feature maintains the room temperature steadily at 8°C and prevents the room from freezing
- Display Dimmer to eliminate light at night
- **Built-in Thermostat**: Control the temperature from where the user is and not where the AC is

Button Description	
Start/Stop	Start/Stop indoor unit
Cool	Set to Cooling mode
Heat	Set to Heating mode
Timer on/Timer off	Set the time to turn on or turn off
Temperature	Set the target temperature
Mode	Select the operation mode
Speed	Set the fan speed
Super	Start the strong cooling/heating mode
Dimmer	Turn off the light
8°C Heat	Maintains the room temperature steadily at 8°C
Hor	Set horizontal airflow direction
Mute	Quiet mode
Smart	Set the room temp automatically
Mute	Start the mute mode
Sleep	Start the sleep mode

OPTIONAL WIRING CONTROLLER

- ❑ 24h Real Timer and **Weekly Timer** setting;
- ❑ **Difference between YXE-C01U1(E) and YXE-C02U1(E):**
 - ❖ **Signal receiver** of Remote Control – **only YXE-C01U1(E)**
 - ❖ **Central Controller** for Max. 16 units - **only YXE-C02U1(E)**
- ❑ **Sleep Mode:** Keeps pace with the body' s metabolism at night by moderately increasing the output temperature to eliminate the feeling of being cold at night. This feature also reduces power consumption

YXE-C01U1(E)
YXE-C02U1(E)



Button Description

- 1 ON/OFF BUTTON
The appliance will be started or stopped when this button is pressed.
- 2 RUN INDICATOR
Indicates that the appliance is on.
- 3 MODE BUTTON
Press this button to select the operation mode.
- 4 FAN BUTTON
Used to select fan speed in sequence high-auto-low-medium-high.
- 5 SWING BUTTON (Invalid for some models)
Used to stop or start adjustment louver swinging and set the desired airflow direction.
- 6 TIMER/CLOCK BUTTON
Used to set the current time or set timer ON/OFF.
- 7 SLEEP BUTTON
Used to set or cancel Sleep Mode operation.
- 8 ENTER BUTTON
Used to confirm settings.
- 9 CANCEL BUTTON
Used to cancel settings.
- 10 ADD.FUNC. BUTTON (Invalid for some models)
Used to set filter cleaning, hot water, fresh air, electric heater, etc.
- 11 INCREASE SETTING BUTTON
Used to raise the set temperature;
It raise the values when setting.
- 12 DECREASE SETTING BUTTON
Used to lower the set temperature;
It lower the values when setting.
- 13 LIQUID CRYSTAL DISPLAY(LCD) SCREEN
Used to display indicator screens.

Technical Spec.

Model	ADT-24UX3SALM
Indoor unit model	ADT-24UX3SLM
Outdoor unit model	AUW-24U3SA

PERFORMANCE DATA

Power supply	Ph-V-Hz	208/230V,1Ph,60Hz
--------------	---------	-------------------

Cooling

Capacity	Btu/h	24000
Input	W	2300
Rated current	A	10.5
EER2	Btu/w	10.45
SEER2	Btu/w	18

Heating at 47

Capacity	Btu/h	26000
Input	W	2460
Rated current	A	11.2
COP2(47°F)	W/W	3.1
HSPF2	Btu/w	9.5
COP2(5°F)	W/W	2.02

Electrical

MINIMUM CIRCUIT AMPACITY	A	23
MAX. FUSE	A	35
Connection wiring		4*16 AWG

Compressor

Type		ROTARY
Brand		GMCC
Capacity	Btu/h	26085
Input	W	2080
Rated current(RLA)	A	16.1
Locked rotor Amp(LRA)	A	---
Thermal protector		---
Thermal protector position		---
Refrigerant oil/oil charge	ml	VG74 /670

SYSTEM DATA

Design pressure	PSIG	550/240
Refrigerant type	oz	R410A/91.7
Refrigerant precharge	ft	25
Additional charge per ft.	oz	1.23
Liquid side/ Gas side	mm(in)	Φ9.52/Φ15.9(3/8"/5/8")
Max. refrigerant pipe length	ft	164
Max. difference in level	ft.	98

ESP

ESP range	In. wg.	0.1-0.4
-----------	---------	---------

Technical Spec.

INDOOR UNIT DATA

Indoor fan motor		
Model		SIC-70CW-F195-1
Type		DC
Input		95
RLA	A	0.5
LRA	A	---
Winding Resistance	Ω	---
Capacitor	μF	---
Speed(Hi/Mi/Lo)	r/min	1010/890/780
Air flow & Noise level		
Indoor air flow (Hi/Lo)	CFM	706/588/500
Indoor noise level (Hi/Lo)	dB(A)	42/38/36
Indoor unit		
Dimension(W*H*D)	inch	35-3/8×10-5/8×28-3/8
Packing (W*H*D)	inch	46-1/8×13-3/8×34-1/4
Net/Gross weight	lbs.	66.1/77.2

OUTDOOR UNIT DATA

Outdoor fan motor		
Model		SIC-71FW-D8121-1
Type		DC
Input		121
RLA	A	1
LRA	A	---
Winding Resistance	Ω	---
Capacitor	μF	---
Speed	r/min	830
Air flow & Noise level		
Outdoor air flow	CFM	2235
Outdoor noise level	dB(A)	55
Outdoor unit		
Dimension(W*H*D)	inch	37-3/8×33-1/8×13-3/8
Packing (W*H*D)	inch	43-3/4×36-1/4×18-1/8
Net/Gross weight	lbs.	155.1/166.4
Operation temperature		
Indoor(cooling/ heating)	Deg. F	62~90/32~86
Outdoor(cooling/heating)	Deg. F	5~118/ -4~75

ESP. Chart

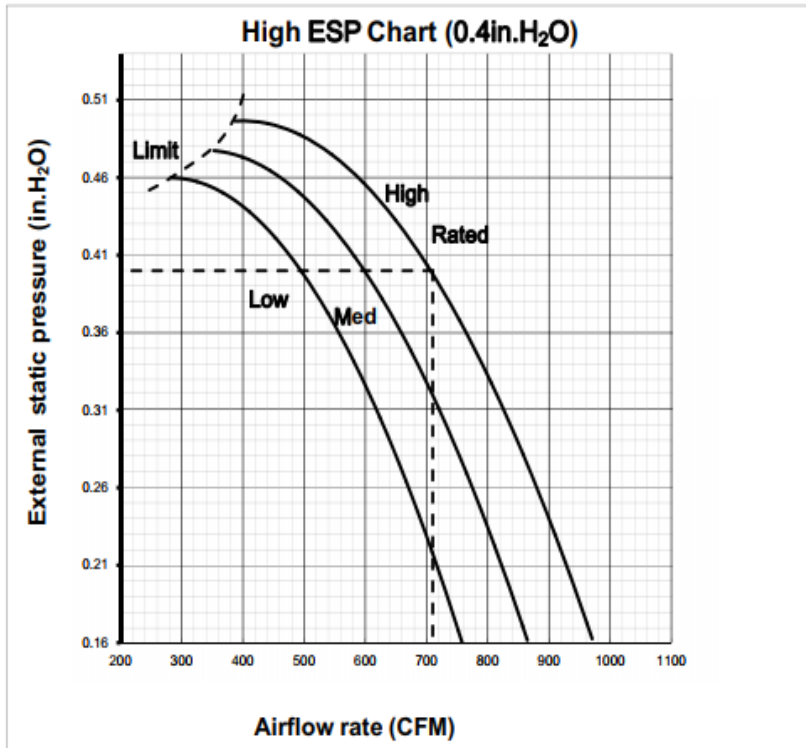
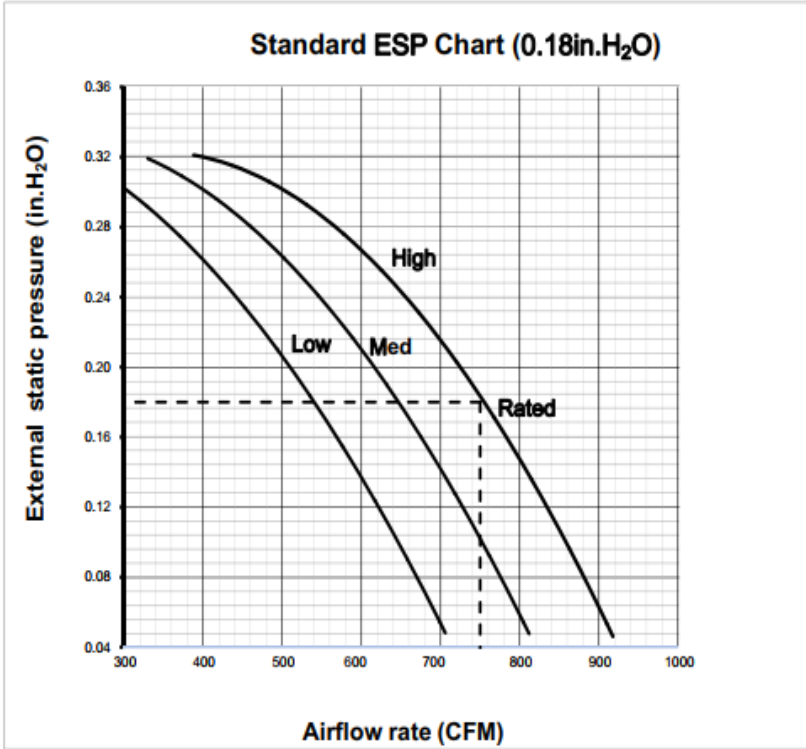

DIMENSIONAL DRAWING Duct

Unit: inch(mm)

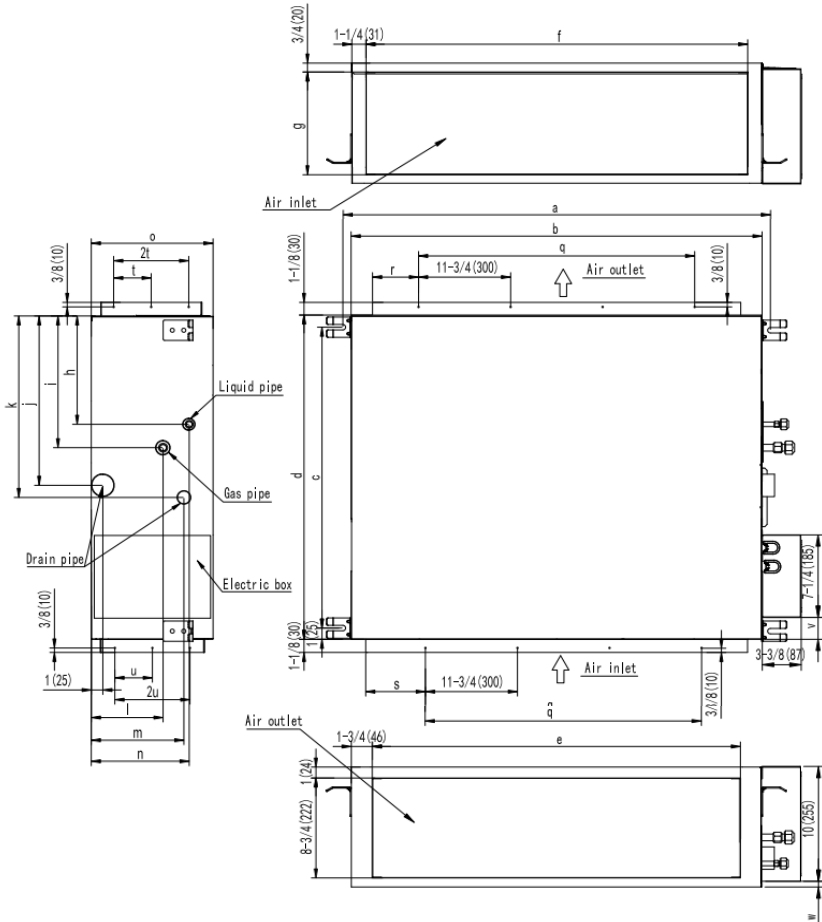

Model	a	b	c	d	e	f	g	h	i	j	k	l	m	n	o	q	r	s	t	u	v	w
24K	36-3/4 (934)	35-3/8 (900)	26-3/8 (669)	28-3/8 (720)	31-3/4 (805)	32-7/8 (835)	9 (228)	9-1/2 (242)	11-5/8 (294)	14-7/8 (378)	16 (405)	6-1/8 (156)	8 (202)	8-3/8 (214)	10-5/8 (270)	23-5/8 (600)	4 (102)	4-5/8 (117)	3-1/4 (82)	3-1/4 (82)	1-7/8 (49)	1/4 (5)
36K	52-1/2 (1334)	51-1/8 (1300)	29-3/4 (756)	31-1/2 (800)	47-1/2 (1205)	48-5/8 (1235)	12-1/8 (308)	9-3/8 (237)	12-3/8 (312)	14-3/4 (375)	15-3/4 (400)	8 (204)	7-3/8 (186)	9-1/2 (242)	13-3/4 (350)	35-3/8 (900)	6 (153)	6-5/8 (168)	3-1/2 (90)	5-1/2 (140)	4-3/8 (110)	1-7/8 (49)

DIMENSIONAL DRAWING Condensing Units

Unit: inch(mm)

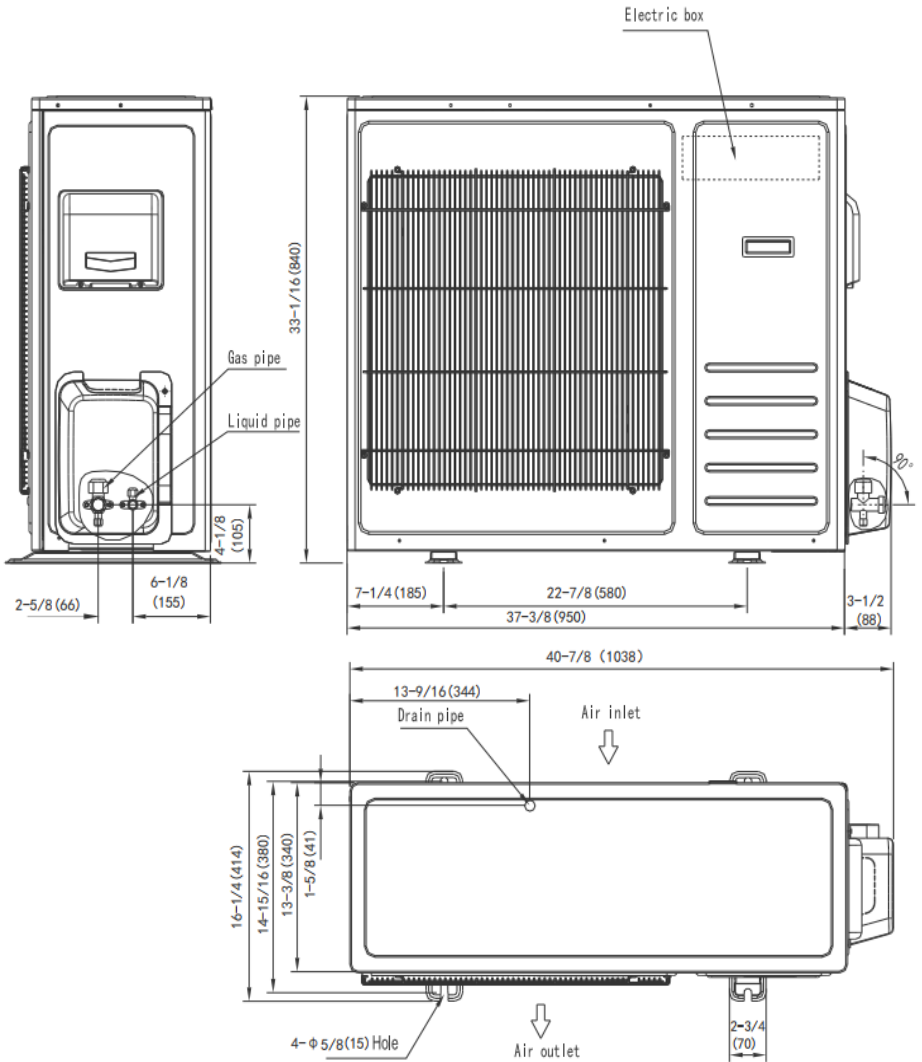

Note: Front Panel maybe different as customize part