



Empowering you to work smarter

NX4 NX4V Nexus Digital Manifold Gauge User Manual



NAVAC Inc.
www.NavacGlobal.com
Tel/Fax: +1 877 MY-NAVAC
877 696 2822
MADE IN PRC



Failure to follow warnings could
result in death or serious injury.

**SAVE THIS MANUAL
FOR FUTURE REFERENCE**

CONTENTS

I. Safety Information	01
II. Product Overview	02
III. Technical Specification	02
IV. Indicator Light	03
V. Icons	03
VI. Auto-Shutdown	03
VII. Function Introduction	03
VIII. Calibration	03
IX. Bluetooth Pairing	04
X. Parameter Setting	04
XI. Manifold Gauge Mode	05
XII. Leak Test Mode	06
XIII. Evacuation Mode	07
XIV. Decay Test Mode	08
XV. Exploded View	09
XVI. NX4 Refrigerant Update Via MyNAVAC App	10
XVII. NMV1S Overview	11
XVIII. Function Introduction	11
XIX. Technical Specifications	12
XX. Display Range	12
XXI. Automatic Shutdown	12
XXII. Operation	13
XXIII. Warning	14
XXIV. Product Overview	16
XXV. Technical Specification	16
XXVI. Screen Display	16
XXVII. Indicator Light	17
XXIII. Alarm	17
XXIX. Bluetooth Connection	17
XXX. Automatic Shutdown	17
XXXI. Key Function	17
XXXII. Exploded View	18
XXXIII. Guide for App Download & Connection	19
XXXIV. Page Introduction	20
XXXV. Basic Functions	21
XXXVI. Basic Functions	22

This series of products are app products, which can be connected with NAVAC'S APP "my NAVAC". Please refer to the end of the manual for downloading the connection guide.

I. Safety Information

Use the instrument only as specified in this manual. Otherwise, the protection provided by the instrument may be impaired.

To avoid personal injury, follow these guidelines:

- Most governments and legal authorities require that HVAC technicians be trained and certified in the safe and proper operation of HVAC tools, such as this instrument. Since this tool may be connected to many types of equipment through a limitless combination of hoses and fittings, proper training is essential for safe use.
- Read the entire Users Manual before using the instrument.
- Use the instrument only as described in the Users Manual, otherwise the protection provided by the equipment may be impaired.
- Do not use the instrument if it is damaged. Before you use the instrument, inspect the case. Look for cracks or loose components.
- The instrument contains no internal user-serviceable parts. Do not open the instrument.
- Do not use the instrument if it operates abnormally. Protection may be impaired. When in doubt, have the instrument serviced.
- Do not operate the instrument around explosive gas, vapor, or dust.
- The refrigerant database in this unit may include refrigerants classified as flammable. If such refrigerants are selected, the operator may need additional certifications and/or training. Consult your government and legal authority and comply fully with all requirements.
- Always wear eye and skin protection when working with refrigerants. Escaping refrigerant vapors present a freezing hazard. Do not direct refrigerant vapors venting from hoses towards the skin.
- Do not exceed the pressure limits specified in this manual.

Warning

This product operates under high pressure. Follow all safety guidelines regarding refrigerant handling including wearing Personal Protective Equipment such as safety glasses, and gloves.

II. Product Overview



III. Technical Specification

Model	NX4	NX4V
Accessory	2 Temperature Probes, Charging Cable, Carry Case	NMV1S Micron Gauge in additional to the NX1 Kit
72 Refrigerant Types	R-11, R-12, R-13, R-22, R-23, R-32, R-113, R-114, R-115, R-116, R-123, R-124, R-125, R134a, R-236fa, R-245fa, R-290, R-401A, R-401B, R-402A, R-402B, R-403B, R-404A, R-406A, R-407A, R-407B, R-407C, R-408A, R-409A, R-410A, R-413A, R-414A, R-414B, R-416A, R-417A, R-417C, R-420A, R-421A, R-421B, R-422A, R-422B, R-422C, R-422D, R-424A, R-427A, R-428A, R-434A, R-437A, R-438A, R-448A, R-449A, R-450A, R-452A, R-452B, R-453A, R-454B, R-458A, R-500, R-501, R-502, R-503, R-507A, R-508B, R-513A, R-600, R-600a, R-601, R-601a, R-744*, R-1233zd, R-1234yf, R-1234ze *Maximum pressure: 1087 psi (7500 kPa) Firmware can be updated at NAVAC website or with MyNAVAC™ App	
Max. Over Pressure	1087 psi (7500 kPa)	
Pressure Unit	bar, Mpa, -Kpa, psi, kgf/cm ²	
Vacuum Unit	Pa, micron, mBar, mmHg	
Temperature Unit	°C, °F	
Pressure Scale	-1-50 bar, -0.1-5 Mpa, -100-5000Kpa, -14.5-725psi, -1.02-51kgf/cm ²	
Resolution	0.01 bar, 0.001Mpa, 1Kpa, 0.1psi, 0.01kgf/cm ²	
Temperature Resolution	32-104°F (0-40°C)	
Battery	3000 mAh Li-polymer	
Connection	(1)3/8" sae (3) 1/4" sae	
Sensor	Digital Sensor	
Unit Dimension	7.75"x2.68"x10.28"	
Unit Weight	3.9 lbs	

IV. Indicator Light

Always on/ Flashing	Power on	Power off
	Bluetooth is not connected	/
	Bluetooth is connected	/
	Device power is low	Charging
	/	Fully charged

V. Icons

: Power display;

: Flashing - low battery alarm,
T1 - low battery of Thermometer -LP;
T2 - low battery of Thermometer -HP;
VG - low battery of Vacuum Gauge;

: Bluetooth connection identification; 0 / 1 / 2 / 3 / 4 indicates the number of Bluetooth connections, indicates no connection.

VI. Auto-Shutdown

1. Pressure value stays at 0, no action on buttons, automatic shutdown after 30 minutes;
2. Pressure sensor malfunction, no action on buttons, automatic shutdown after 10 minutes;
3. Low battery, automatic shutdown.

VII. Function Introduction

On/Off key: Press and hold for 2 seconds to turn on/off the device;

Mode Selection Key: Manifold Gauge Mode, Leak Test Mode, Evacuation Mode and Decay Test Mode;

Setting Key: Press and hold for 2s to enter the parameter setting;

Up Key: Moves the parameter upwards;

Down Key: Moves the parameter downwards;

Confirm Key: Setup interface to confirm parameters; Start/Stop in Leak Test mode.

VIII. Calibration

Press and hold for 2 seconds to zero out the pressure.

IX. Bluetooth Pairing

The first time you connect the vacuum gauge NMV1S, you need to do the Bluetooth pairing manually:

1. To pair the high pressure side, press and hold **ENTER** + **▲** for 3 seconds.
2. To pair the low pressure side, press and hold **ENTER** + **▼** for 3 seconds.
3. To pair the vacuum gauge, click "Mode" button to switch NX1 to Evacuation Mode, the press and hold **ENTER** + **▼** for 3 seconds.

At this time, the Bluetooth logo "CONNECT NMV1S" of the digital display meter is flashing, long press **ENTER** + **▼** for more than 3 seconds to enter the Bluetooth pairing interface of the vacuum gauge, "-----" is lit in sequence, indicating that the device is searching for Bluetooth, if the screen shows "b7c", indicating that the Bluetooth has been successfully connected, and then it will return to the interface of the Evacuation Mode in 2s, and the Bluetooth logo "CONNECT NMV1S" will disappear.

Notes:

- (1) When in Bluetooth pairing, no other operation can be performed for 30 seconds.
- (2) The digital gauge will automatically connect to the paired vacuum gauge when it is in vacuum mode.

X. Parameter Setting

In Manifold Gauge mode, Leak Test mode, Evacuation mode, press and hold **SET** key for 2s, enter the parameter setting interface, press **▼** or **▲** cycle and select the parameter content (refrigerant setting, press and hold to scroll through refrigerant type), press **ENTER** will switch to the next parameter setting, when all the parameter setting is completed, the screen will return to the original interface.

Factory Refrigerant Type: R-11, R-12, R-13, R-22..... (Total 72 types)

Pressure unit: MPa, bar, kgf/cm2, psi, Kpa.

Temperature unit: °C, °F

Vacuum unit: Pa, micron, mBar, mmHg

Sound: ON/OFF

Backlight: 1min/3min/10 min/OFF (the number indicates that the backlight turns on for a few minutes after operation without buttons, and OFF indicates that it turns off)

XI. Manifold Gauge Mode

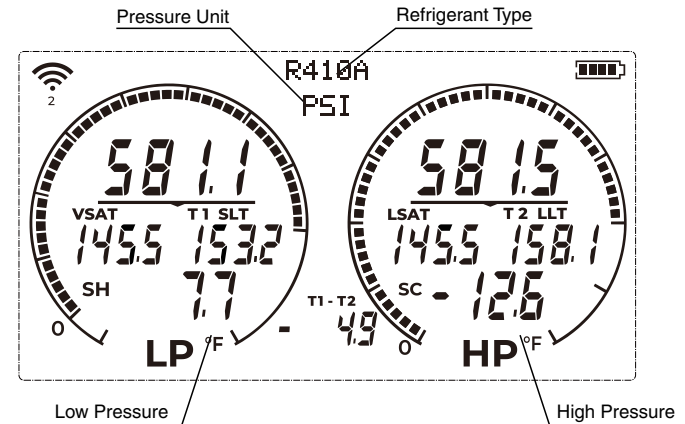

Pressure values at the high and low pressure ends are displayed as gauge pressure.

(Gauge pressure = measured pressure - atmospheric pressure)

VSAT: Vapor saturation temperature.

LSAT: Liquid saturation temperature.

T1 SLT: Suction line temperature.

T2 LLT: Liquid line temperature.

SH: Superheat value $SH = T1\ SLT - VSAT$.

SC: Subcooling value $SC = LSAT - T2\ LLT$.

T1 -T2: temperature difference.

Dial scale (in Mpa):

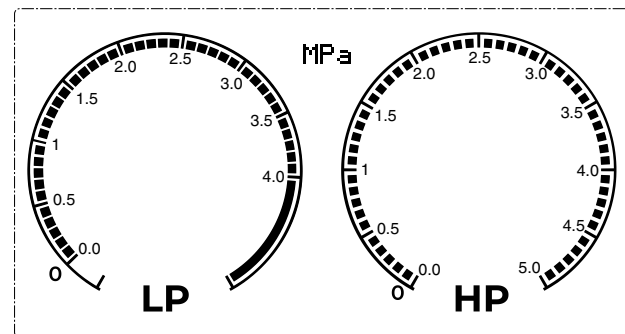

When the pressure value is less than 0, the pressure unit automatically switches to inHg.

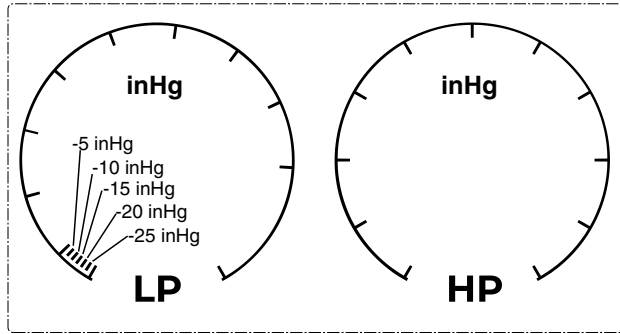

XII. Leak Test Mode

Screen Display Introduction

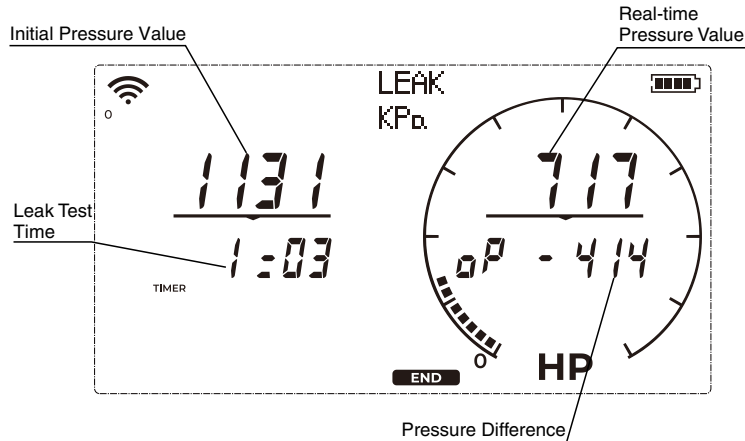

Operation

Note: the system needs to be connected to the **high side** of the manifold gauge.

- (1) Press the "ENTER" key to start the leak test. The bottom of the screen displays "START", the right side of the screen displays the real-time pressure value, the leak test timer starts, and the value of "d P" starts calculating.

- (2) Press the "ENTER" key again, the bottom of the screen shows "END", the leak test timer stops and the final pressure difference is displayed at "d P";
- (3) Press the "ENTER" key again to reset.

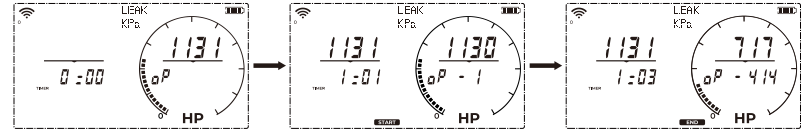

XIII. Evacuation Mode

Screen Display Introduction

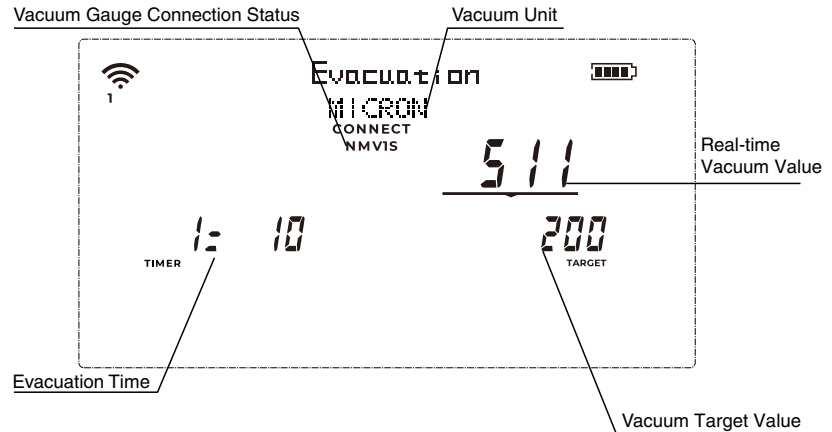

Evacuation value display range is 0-9999;
 10000-19999 micron is displayed as "1E4";
 20000-29999 micron is displayed as "2E4";
 2:30000 micron is displayed as"....".



XIV. Decay Test Mode

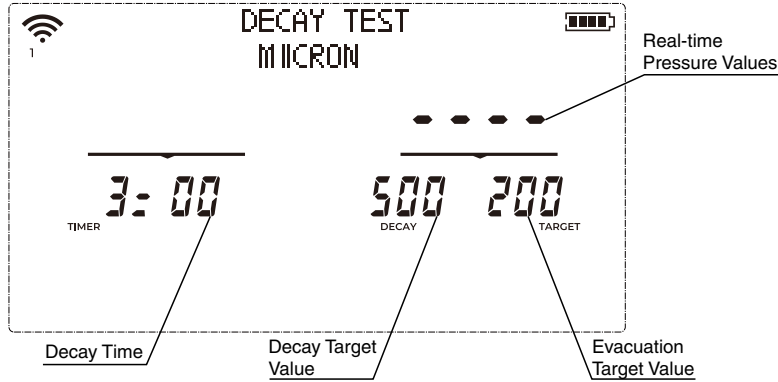

Decay Test Mode Parameter Settings

Press and hold the "SET" key for two seconds to enter the vacuum attenuation parameter setting interface. There are 4 types of setting parameters, the order are: vacuum unit, "TARGET", "DECAY" and "TIMER". When the parameter is selected, the corresponding icon and value will flash, press the "▼" or "▲" key to move down or up to select the value cyclically, press the "ENTER" key to lock and save the parameter, which will then display continuously and automatically switch to the next parameter setting.

Function

When connected to the vacuum gauge, the digital display will receive the "TARGET", "DECAY" and "TIMER" setting values from the vacuum gauge and display them in the corresponding positions on the screen.

- (1) Start vacuum extraction to bring the vacuum level of the measuring device down to the "TARGET" setting.
- (2) The vacuum pump stops when the vacuum value exceeds the "TARGET" setting, and the vacuum decay mode is activated, with the "TIMER" starting to count down.
- (3) If the vacuum level stays within the "DECAY" setting during the time set by the "TIMER," it will display "PASS" (Pressure Holding Successful); otherwise, it will display "FAIL."

XV. Exploded View

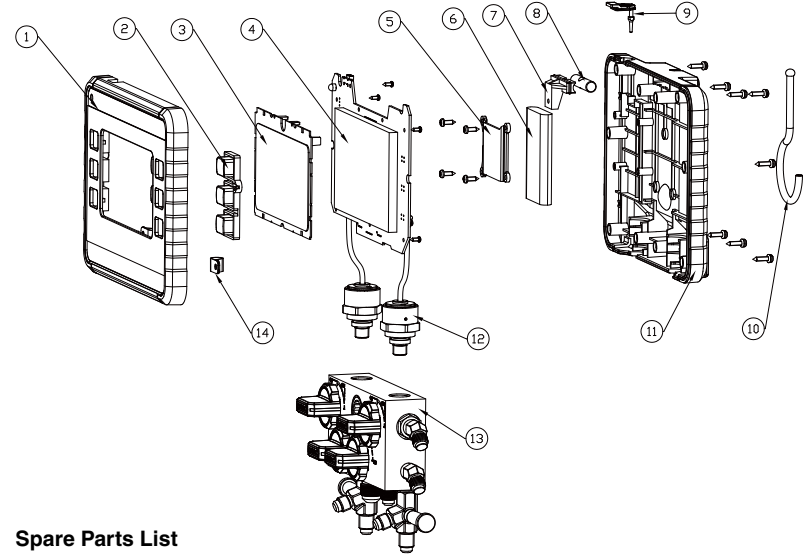

Spare Parts List

No.	Item
1	Top Cover
2	Left /Right Button
3	PC Transparent Plate
4	PCBA
5	Battery Cover
6	Li-ion Battery
7	Retainer Block
8	Retainer Block
9	Rubber Plug
10	Hook
11	Rear Cover
12	Sensor Assembly
13	Four Valve Body Assembly
14	Wire Clamp

XVI. Nx4 Refrigerant Update Via MyNAVAC App

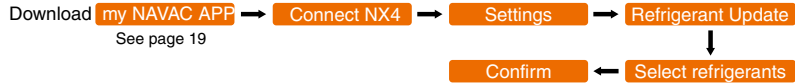

Refrigerant update conditions:

1. Both gauge pressures should be 0, and the vacuum reading should display " - - - - ".
2. The unit power should be greater than 50%.
3. Ensure the unit is not in the setup screen.

During the update process using the APP, the unit's refrigerant model display area will show "Loading...". Upon successful completion of the update, "Complete" will be displayed.

Upon successful update completion, the display will show "Complete", and the unit will automatically return to the original interface. The refrigerant model number will display "....." indicating that no refrigerant is currently selected, and parameter settings are required.

If the refrigerant data update fails, "Failed" will be displayed. After 3 seconds, the unit will automatically return to the original interface, retaining the original refrigerant data.

XVII. NMV1S Overview



XVIII. Function Introduction

1. Operation Key

- 1.1. : Power on / off key. Press 1 second to turn on, press 2 seconds to turn off.
- 1.2. : Down key. In setting mode, adjust settings. In decay testing mode, set timer and leakage rate.
- 1.3. : Up key. In setting mode, adjust settings. In decay testing mode, set timer and leakage rate.
- 1.4. : Parameter setting key. Interface display " o o o o " press and hold for 2s to enter the parameter setting interface.

2. Screen Display

- 2.1. SET : Parameter setting mode.
- 2.2. : Power indicator.
- 2.3. : Bluetooth connection indicator;
0 / 1 / indicates the number of Bluetooth connections.
- 2.4. Evac Target: minimum target vacuum;
(Vacuum value expected to be reached by the evacuation system)
- 2.5. Decayed target: the maximum target vacuum degree which should be greater than the target vacuum value;
- 2.6. Decay time: pressure maintaining time. (Triggered only when the minimum and maximum target vacuum are not setting to "off");
- 2.7. Decay test: enter the decay testing procedure;
- 2.8. Rate: leakage rate, leakage rate unit: / min.

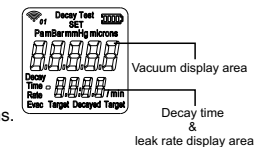

XIX. Technical Specifications

Model	NMV1S
Location	Indoor use
Altitude	≤5000m
Humidity	≤75% R.H.
Intended Use	Pressure Measurement
Maximum Overload Pressure	50 psi / 3.4 bar
Range	0-25000 microns, 0-3333.3 Pa, 0-33.3 mBar, 0-25 mmHg.
Resolution	0.01 micron (<10 microns), 0.01Pa (<10 Pa), 0.001 mBar, 0.001 mmHg
Accuracy	50~1000 microns:± 5% of reading(at 68 F)
Operating Temperature	32~104 F (0~40°C)
Battery	2000 mAh Li-polymer
Charge Parameter	Max. 5V= 2A
Unit	Pa, mBar, mmHg, microns
Connections	1/4" SAE
Sensor	Pirani sensor
Weight	6.2 oz

Indicator Light:

	Indicate
	Low Battery
	Powered on, Bluetooth is not connected
	Bluetooth is connected

XX. Display Range

Vacuum display range for vacuum pumping: 0-25000 microns (3333.3 Pa, 33.3 mbar, 25 mmHg). Over range display "o o o o o".

XXI. Automatic Shutdown

When the vacuum gauge has a reading displayed, the automatic shutdown program will not be triggered for 2 hours; The automatic shutdown program will be triggered only when the interface displays atmospheric pressure "----", and without any operation on the interface.

XXII. Operation

1. Start, Shut off

Press 1 second to turn on, press 2 seconds to turn off.

2. Parameter Setting Interface

2.1. The vacuum display area displays "----", long press 2 seconds to enter the parameter setting interface.

2.2. Vacuum unit setting:

Press , to select unit, press to lock and switch to next parameter setting.

2.3. "Evac target" setting: (minimum target vacuum)

Press , to select the flashing value, then press to lock and stay on, then switch to the next "delayed target" setting.

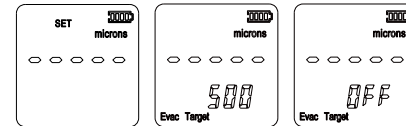

2.4. Delayed target setting: (maximum target vacuum)

Press , to select, the value is higher than the value set by "evac target" or "off".

If "off" is selected, the "delay time" pressure maintaining time will default to "off", and skip directly to enter the sound setting.

2.5. Pressure maintaining time setting (delay time)

After the "delayed target" setting is completed, if the values of 3&4 are not "off", press enter to the setting of "delayed time". Press , to select. Then press to lock and stay on, then switch to the next parameter setting.

2.6. Sound setting "beep"

Press , to select, press to lock and then enter the next parameter "backlight" setting.

2.7. Backlight setting "B-L"

Press , to select, press to lock, it will return to the standby interface automatically.

3. Evacuation and Pressure Maintaining Interface I

(Both evac target and Delayed target are not set to off)

3.1. After the vacuum pumping starts, the actual measured vacuum reading keeps getting smaller.

When it reaches the "evac target" setting value, the value such as "XXX" keeps flashing. Press (any key) to turn off flashing and stop the prompt.

3.2. When the actual measured vacuum reading is less than the "evac target" value and rises to this reading, the pressure maintaining time starts to count from 0. Until exiting this interface or complete pressure maintaining. (if the vacuum is less than the evac target value, time will be paused until the collected number is greater than evac target. Then continue timing. Press or to select evac target, delayed target, delayed time and rate.

3.3. When do decay testing, If the vacuum reading does not exceed the set value of delayed target. It displays "pass" until you press (any key) to stop flashing, exit the prompt and return to the main standby interface.

- 3.4. When do decay testing, if the vacuum reading gets larger, reaches and exceeds the set value of delayed target, the buzzer will alarm, and the word "FAIL" will flash until you press any key to stop flashing and exit the prompt, and return to the standby main interface.
- 3.5. If pressure holding time is set to "off", alarm will start after the vacuum value exceeds decayed target.

4. Evacuation and Pressure Maintaining Interface II (Evac target and Delayed target are set to off)

- 4.1. Evac target is set to off and delayed target is not set to off when the real-time vacuum reduces, the prompt of delayed target value will not be triggered. The prompt of "fail" and "alarm tone" will be triggered only when the vacuum value increases to the delayed target value.
- 4.2. Evac target is set to non off and delayed target is set to off when the target vacuum reduces, the "alarm tone" beep of evac target value will be triggered. When the vacuum value increases, the "fail" alarm will not be triggered.
- 4.3. Both evaluation target and delayed target are set to off all alarm prompts will not be triggered.

5. Zero setting calibration

Under the atmosphere, press and hold key for more than 2 seconds until the vacuum display area displays "-----", the full calibration is completed.

XXIII. Warning

WARNING: Read all safety warning and instructions. Failure to follow the warnings and instructions may result in electric shock, fire and/or serious injury.

1. Do not dismantle, open or shred rechargeable Li-polymer battery pack.
2. Do not expose battery pack to heat or fire. Avoid storage in direct sunlight.
3. Do not short-circuit a battery pack.
4. When battery pack is not in use, keep it away from other metal objects, like paper clips, coins, keys, nails, screws or other small metal objects, that can make a connection from one terminal to another, Shorting the battery terminals together may cause burns or a fire.
5. Do not subject battery pack to mechanical shock.
6. In the event of a battery leaking, do not allow the liquid to come in contact with the skin or eyes. If contact has been made, wash the affected area with copious amounts of water and seek medical advice.
7. Seek medical advice immediately if a battery pack has been swallowed.
8. Do not use any battery pack which is not designed for use with the equipment.
9. Use only the battery pack in the application for which it was intended.
10. Do not use a battery pack or appliance that is damaged or modified. Damaged or modified batteries may exhibit unpredictable behavior resulting in fire, explosion or risk of injury.
11. Keep battery pack out of the reach of children.
12. Always purchase the correct battery for the equipment.
13. Keep battery pack clean and dry.
14. Wipe the battery pack terminals with a clean dry cloth if they become dirty.
15. Dispose of properly.
16. Follow all charging instructions and do not charge the battery pack or appliance outside of the temperature range specified in the instructions. Charging improperly or at temperatures outside of the specified range may damage the battery and increase the risk of fire.
17. Instructions regarding battery charging, information regarding ambient temperature range for battery use and storage, and the recommended ambient temperature range for charging system during charging.

Operating Temperature	Charge	32~104°F(0~40°C)
	Discharge	14~140°F(-10~60°C)
Storage Temperature	1 month	-4~140°F(-20~60°C)
	3 month	-4~113°F(-20~45°C)
	1 year	-4~77°F(-20~25°C)

18. Rechargeable battery pack need to be charged before use. Always refer to the equipment manual for proper charging instructions. Charge only with USB(Type C) not exceed 5V $\overline{=}$ 2A.

XXIV. Product Overview



XXV. Technical Specification

Model	NST1	NST2
Measurement range	-40~257°F (-40~125°C)	
Accuracy	±2.34°F (±1.3°C)	
Resolution	0.1	
Operating temperature	-40~80°C, 10~90%RH	
Battery	2 x AAA	
Sensor	Pt100(ITS-90)	
Unit Weight	0.35 lbs	

XXVI. Screen Display

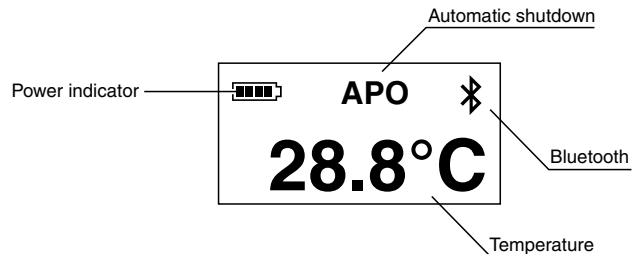

XXVII. Indicator Light

Power on status: Green light blinks 3 times.

Rest state:

- (1) Entering or exiting function setting, green light flashes 3 times fast.
- (2) Normal function and successful Bluetooth connection, green light flashes slowly.
- (3) Normal function but Bluetooth is not connected, yellow light flashes slowly.
- (4) Low battery or hardware failure, red light flashes slowly.

XXIII. Alarm

Over range:

- (1) When the measured temperature is greater than 125°C and less than 150°C, the temperature value is displayed in red and the buzzer sounds continuously at a frequency of 0.5S.
- (2) When the measuring temperature is less than -40°C or more than 150°C, the display will show "OL" and the buzzer will sound for a long time.

Hardware failure:

- (1) When the temperature sensor fails, "ERR.-" is displayed and the buzzer sounds continuously for 1 second.
- (2) When Bluetooth is faulty, the buzzer sounds continuously for 1 second.

XXIX. Bluetooth Connection

The device will keep the Bluetooth broadcast status after powering on; if the device is not connected, "⌘" is blinking constantly; if the device is connected, "⌘" is always on.

XXX. Automatic Shutdown

When "APO" is turned on, the unit automatically shuts down if no key is pressed for 2 hours.

XXXI. Key Function

Switch on/off: Press and hold the key for 2 seconds to turn on the power, press and hold the key for 3s to turn off the power after turning on the power.

Turn off and light up the screen: under the non-function selection state, press the key to switch back and forth between off and light up the screen.

Function Selection:

- (1) Quickly double-click the button to enter the function setting interface, the setting order is Auto Power Off, Bluetooth Switch and Temperature Unit in order.
- (2) Click the button to select function.

XXXII. Exploded View

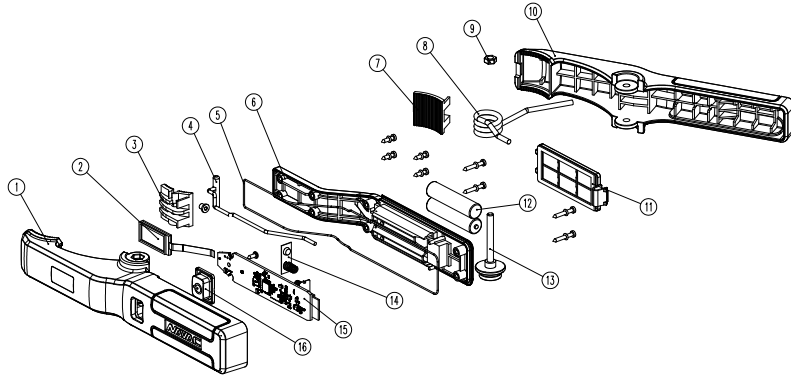

Spare Parts List

No.	Item	Qty
1	Master Clamp Handle	1
2	LCD	1
3	Toothed Block	1
4	Temperature Sensor	1
5	O-ring	1
6	Cover	1
7	Toothed Block	1
8	Spring	1
9	Nut	1
10	Sub Clamp Handle	1
11	Battery Cover Plate	1
12	AAA Battery	2
13	Retaining Stud	1
14	Battery Shrapnel	1
15	PCBA	1
16	Button	1

XXXIII. Guide for App Download & Connection

For Apple:

Search for “myNAVAC” in the App Store, then download and install the app.



For Android:

Search for “myNAVAC” in the Google Play Store, then download and install the app.



Log In

Account Login: Internet connection is required, all data records are stored in the backend server.

Guest mode: No internet connection is required, all data records are stored locally on the cell phone.

XXXIV. Page Introduction

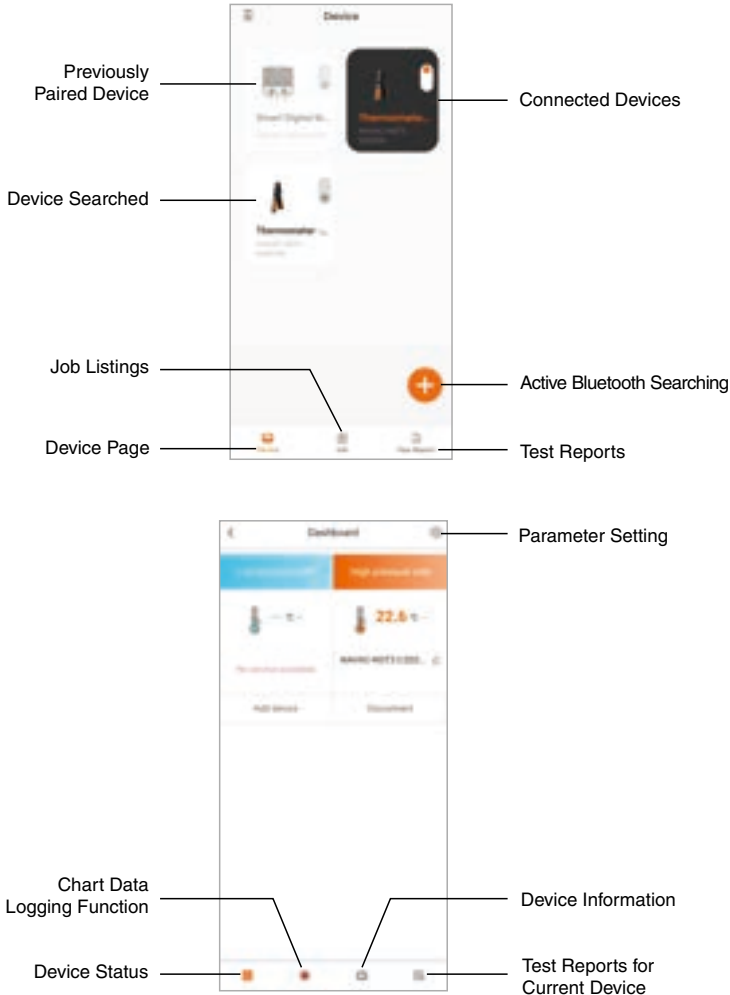

XXXV. Basic Functions

Link Device

Turn on your phone's Bluetooth. In the main interface, tap the plus button in the lower right corner to search available devices.

(Note: If you are using the NX1 with a vacuum gauge and temperature probes, please connect the vacuum gauge and temperature probes to the NX1 first, and then connect the NX1 to the APP).



Find the target device you need to connect to, click the plus sign in the upper right corner and wait for the connection to be established.



If the connection is successfully established, it will automatically jump to the main interface, click the device icon to enter the device interface.



Data logging

Click "●" in the bottom navigation bar to turn on the data logging function. Click Start to record data.

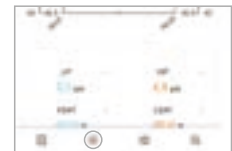

Click again on the bottom navigation bar "●", to save or restart the record. Then select a Job you wish to save to.



