

The Sidewinder tube oil skimmer removes oil from the tightest places, even off the floor. It can snake around corners, enter through narrow slits, and be moved from machine to machine in a minute.

FEATURES:

- Skims underneath conveyors, enclosed sumps, and hard to-access areas
- Pick the reach you need: sizes available from 8" up to 95"
- Installs in seconds
- Industrial-grade pick-up tubing uses ceramic scraper
- Large oil discharge port
- 1 quart per hour oil removal capacity
- Only 1/2x3" (13x76mm) sump access needed!
- Maximum temperature 90°F (30°C)
- Continuous-duty motor
- 90-day warranty
- The Sideways™ Skimmer

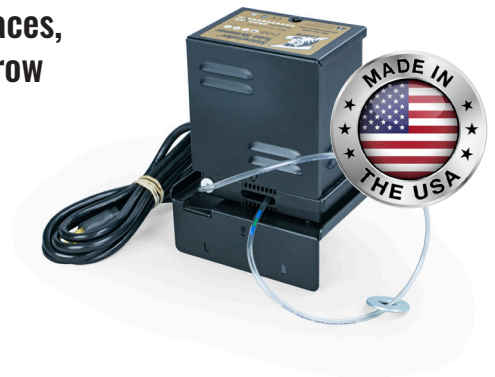

To determine the reach required, measure the distance from the mounting point to the lowest operating fluid level. Reach sizes available in 3" increments, to maximum reach of 95". Please specify by changing suffix.

Model	Part Number	Description	Notations
Sidewinder	ZVA8-08	Sidewinder Tube skimmer with 8" reach	100-120v, 60Hz, 28 rpm
	ZVA8-08E	Sidewinder Tube skimmer with 8" reach	208/220/240v, 50Hz, 23/28 rpm
	ZVA8.2-08 110v,	Sidewinder Tube skimmer with 8" reach	110v, 60Hz, 7 rpm
	ZVA8.4-08	Sidewinder with Integrated Timer	
Magnetic Base Option	ZXB8-Mag	Magnetic base option for Sidewinder without Diverter	
Diverter	BGST4	Oil/coolant separator for Sidewinder and Belt skimmers	Will raise unit 2.5", please account for this when determining required reach.
LockJaw	BGX2	Lockjaw mounting clamp for Sidewinder with Diverter only	Ideal for skimmer portability and for drum use.
Timer	XETIMER	Timer for mechanical skimmers 24 hour, 3 setting	External, plug-in type
	XETIMER-GSBZ	20v, 60Hz, 7 day, 2 hour interval settings.	Integrated with motor

*Longer reach sizes available, in 3" increments, to 95" max. Please change suffix.

OPTIONAL ACCESSORIES



Diverter™ (BGST4)

Upgrade your belt, or tube-type oil skimmer so that it removes ONLY oil from your sump. Pays for itself in saved coolant.



Timer Options

(XETIMER- Standard)
(XETIMER-GSBZ - Integrated)
Integrated timer for mechanical skimmers



Sidewinder base plate (#ZVA8)



Magnetic base option (#ZXB8-MAG)

Not for use with Diverter™



Zebra Skimmers Corporation

27000 Richmond Road #1 | Solon, OH 44139 | Toll Free: 888.249.4855 | Fax: 440-349-1211
sales@zebraskimmers.com | www.zebraskimmers.com

ZVA8 Series - Technical Specifications

100/120v Motor:	100-120v, 1 phase, 60/50Hz, .75LRA, 82w, .11hp, 28 rpm, fan-cooled, 8' 3-prong cordset
208/220/240v Motor:	110v, 60Hz, 7 rpm, .7 amps, 1 phase, 77w, .1 hp
110v, 7 rpm Motor:	110v, 60Hz, 7 rpm, .7 amps, 1 phase, 77w, .1 hp
Mounting Holes:	13/64" (5.16mm) slotted, 3 places, 3" (7.62cm) between centers (hardware not provided)
Oil Pickup Tube:	.182" OD, OAL dependent upon reach size
For Fluids:	Max temp 90°F (30°C) and with minimum 5% oil concentration value
Oil Discharge Tube:	Polyvinyl, 1.25" (32mm) ID, 10" (25.4cm) long
Shipping Weight:	6lbs. (2.7 kg)

ZVA8 Series - Replacement Parts & Accessories

MOTORS (FIT MODELS ZVA6, ZVA7 AND ZVA8)

MZ28J7	Replacement motor assembly, with motor, cover and cord. 100-120v, 28rpm, fancooled for continuous-duty.
MZ28J8	110v, 28rpm, fan-cooled for continuous-duty. RAW motor only.
MZ28E1	Replacement motor assembly, with motor, cover, and cord. 208/220/240v, 23/28 rpm, fan-cooled for continuous duty.
MZ28E2	220v, 23/28rpm, fan-cooled for continuous-duty, RAW motor only.
MZ07J7	Replacement motor assembly, with motor, cover, and cord. 110v, 7 rpm, fancooled for continuous duty.
MZ07J8	110v, 7 rpm, fan-cooled for continuous duty, RAW motor only.
ZXRS	Rocher Switch Option (ON/OFF) for Sidewinder motors above.

REPLACEMENT TUBES & CARTRIDGES

ZXCART8-08	Tube & gear cartridge, 8" reach* (new base angle required to retrofit ZVA6, ZVA7 models).
ZT8-08	Replacement tube only, 8" reach* (best for replacement on model ZVA8. For models ZVA6 and ZVA7 refer to tube cartridge #ZX-CART8-08) * Longer reach sizes available, in increments of 3" to 95" max.

BASE ANGLE

ZXB8	Base angle for Sidewinder model 8 cartridge
ZSB8-MAG	Magnetic option for Sidewinder base angle (base angle purchased separately).

ACCESSORIES

BGST4	Diverter™, separates coolant from oil to reduce coolant waste
BGX2	Lockjaw™, easy-mounting fixture for sumps, barrels, and more. Use in conjunction w/BGST4.
XETIMER	Electrical timer, 24 hour, 3-settings per day
XETIMER-GSBZ	Integrated timer, 120v, 60Jz, 7 day, 2 hour interval setting

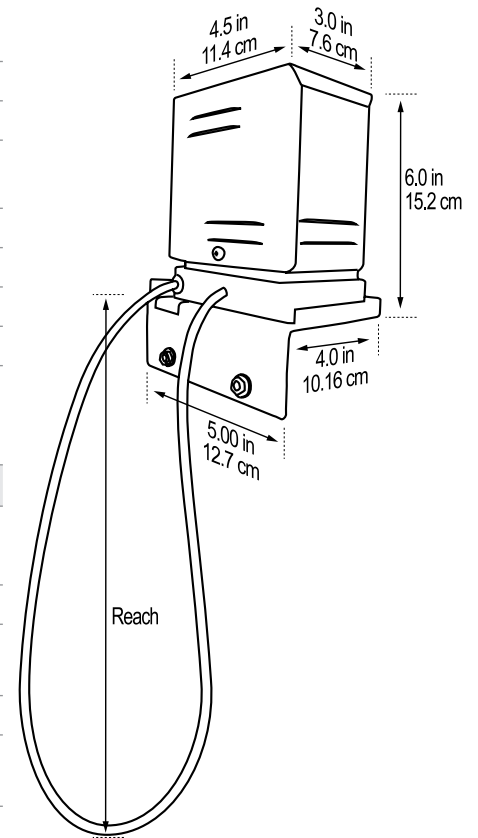

Zebra Skimmers Corporation

27000 Richmond Road #1 | Solon, OH 44139 | Toll Free: 888.249.4855 | Fax: 440-349-1211
 sales@zebraskimmers.com | www.zebraskimmers.com